

**EMICON**  
INNOVATION AS ENERGY



AN ENX TECHNOLOGIES COMPANY

**HEAT PUMPS &  
MULTIPURPOSE UNITS**  
Products Catalogue

## INTRO

3

## 2 PIPE SYSTEMS HEAT PUMPS

<b>LSA/HP</b>	HIGH EFFICIENCY AIR TO WATER HEAT PUMPS	<b>12</b>
<b>LHi</b>	HIGH EFFICIENCY AIR TO WATER HEAT PUMPS WITH INVERTER COMPRESSOR AND AXIAL FANS	<b>16</b>
<b>LHA</b>	HIGH EFFICIENCY AIR TO WATER HEAT PUMPS EQUIPPED WITH SCROLL COMPRESSOR AND AXIAL FANS	<b>24</b>
<b>LHE</b>	HIGH EFFICIENCY AIR TO WATER HEAT PUMPS EQUIPPED WITH SCROLL COMPRESSOR AND AXIAL FANS WITH LOW GWP REFRIGERANT	<b>34</b>
<b>PAE N</b>	HIGH EFFICIENCY AIR TO WATER HEAT PUMPS EQUIPPED WITH SCROLL COMPRESSOR AND AXIAL FANS WITH LOW GWP REFRIGERANT	<b>44</b>
<b>PAH VS</b>	HIGH EFFICIENCY AIR TO WATER HEAT PUMPS EQUIPPED WITH INVERTER SCREW COMPRESSORS AND AXIAL FAN	<b>58</b>
<b>LZT</b>	HIGH EFFICIENCY AIR TO WATER HEAT PUMPS EQUIPPED WITH E.V.I. COMPRESSORS AND AXIAL FANS	<b>64</b>
<b>LZTi</b>	HIGH EFFICIENCY AIR TO WATER HEAT PUMPS EQUIPPED WITH DC INVERTER COMPRESSOR WITH VAPOR INJECTION (EVI) AND AXIAL FANS	<b>78</b>
<b>WZT</b>	HIGH EFFICIENCY AIR TO WATER SPLIT SYSTEM HEAT PUMPS EQUIPPED WITH E.V.I. COMPRESSORS IN TWO SECTIONS	<b>82</b>
<b>WZA</b>	GROUND SOURCE WATER TO WATER HEAT PUMPS EQUIPPED WITH SCROLL COMPRESSOR	<b>88</b>
<b>WHA</b>	GROUND SOURCE WATER TO WATER HEAT PUMPS EQUIPPED WITH SCROLL COMPRESSOR	<b>92</b>
<b>WHK</b>	SUPER-HIGH TEMPERATURE WATER TO WATER HEAT PUMPS EQUIPPED WITH SCROLL COMPRESSOR	<b>98</b>

## 4 PIPE SYSTEMS MULTIPURPOSE UNIT AND HEAT PUMPS

<b>LHi/P4</b>	HIGH EFFICIENCY AIR TO WATER MULTIPURPOSE UNIT AND 4 PIPE HEAT PUMPS EQUIPPED WITH INVERTER COMPRESSOR AND AXIAL FANS	<b>102</b>
<b>LHA/P4</b>	HIGH EFFICIENCY AIR TO WATER MULTIPURPOSE UNIT AND 4 PIPE HEAT PUMPS EQUIPPED WITH SCROLL COMPRESSOR AND AXIAL FANS	<b>110</b>
<b>LHE/P4</b>	HIGH EFFICIENCY AIR TO WATER MULTIPURPOSE UNIT AND 4 PIPE HEAT PUMPS EQUIPPED WITH SCROLL COMPRESSOR AND AXIAL FANS WITH LOW GWP REFRIGERANT	<b>124</b>
<b>GPE N</b>	HIGH EFFICIENCY AIR TO WATER MULTIPURPOSE UNIT AND 4 PIPE HEAT PUMPS EQUIPPED WITH SCROLL COMPRESSOR AND AXIAL FANS WITH LOW GWP REFRIGERANT	<b>134</b>
<b>GPH VS</b>	HIGH EFFICIENCY AIR TO WATER MULTIPURPOSE UNIT AND 4 PIPE HEAT PUMPS EQUIPPED WITH INVERTER SCREW COMPRESSORS AND AXIAL FAN WITH LOW GWP REFRIGERANT	<b>146</b>
<b>LZT/P4</b>	HIGH EFFICIENCY AIR TO WATER MULTIPURPOSE UNIT AND 4 PIPE HEAT PUMPS EQUIPPED WITH E.V.I. COMPRESSORS AND AXIAL FANS	<b>152</b>

# About

Enex Technologies is a transformative world leader in natural and energy efficient cooling, heating, ventilation and refrigeration equipment that began in the 1930s by producing ammonia natural refrigeration equipment, later adding CO<sub>2</sub>, water and propane as natural refrigerants with low global warming potential.

1934  
**SAMIFI  
FRANCE**  
INNOVATION AS ENERGY

1968  
**kobol**  
HEAT EXCHANGERS NATURALLY

1948  
**MORGANA**  
HEAT EXCHANGERS NATURALLY

1984  
**EMICON**  
INNOVATION AS ENERGY

1983  
**ROENEST**  
HEAT EXCHANGERS NATURALLY

1997  
**Arctic**  
INNOVATION AS ENERGY

1993  
**Hidros**  
INNOVATION AS ENERGY

1999  
**ETHRATECH**  
INNOVATION AS ENERGY

2004  
**enex**  
INNOVATION AS ENERGY

# Pioneers and innovators in natural HVACR since the 1930s



2022



# Our numbers

**200M€**  
Revenues

**1000+**  
Employees

**12**  
Factories

**125**  
Countries



★ Headquarter

● Manufacturing, R&D site and commercial office

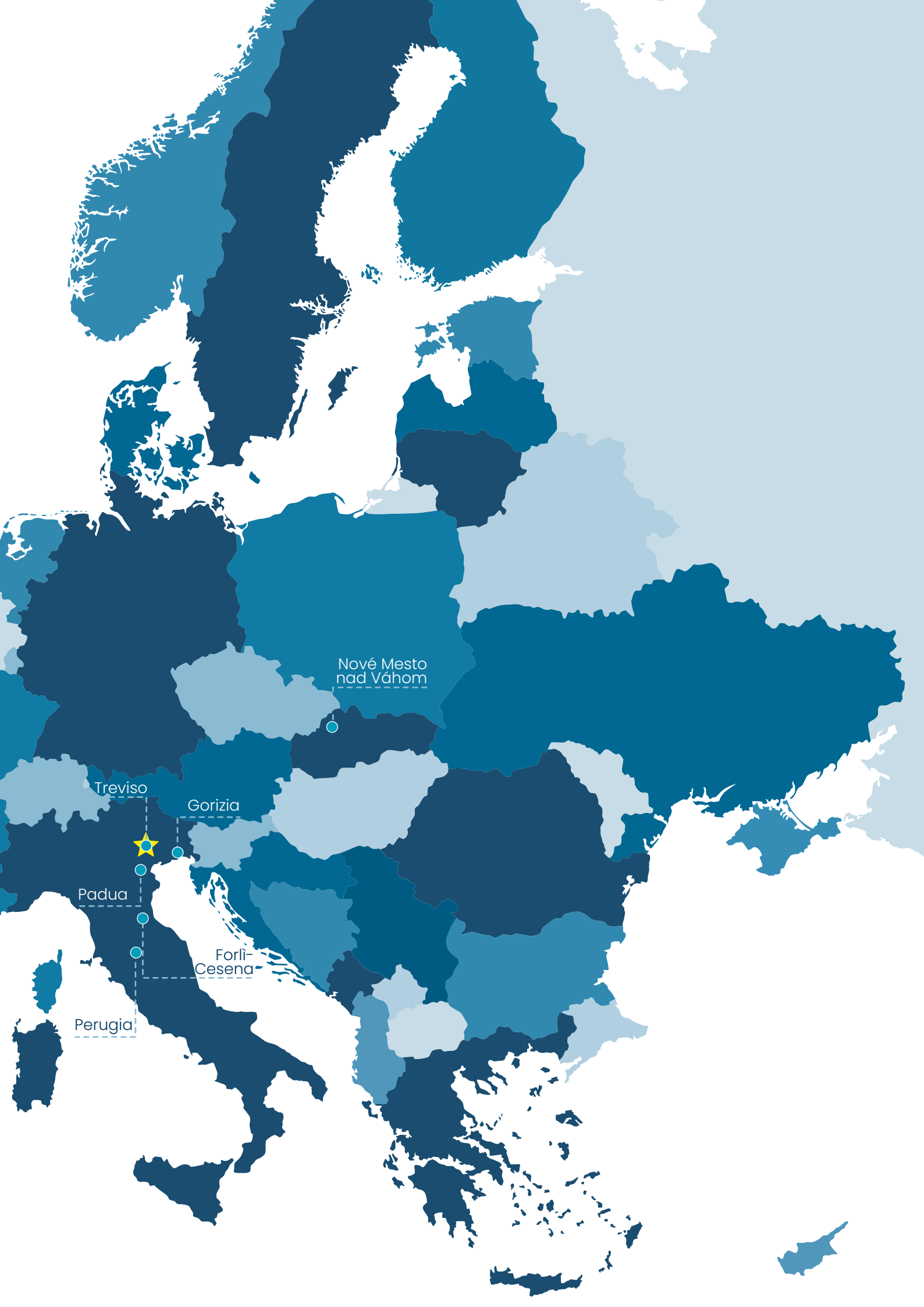

Nové Mesto  
nad Váhom

Treviso

Gorizia

Padua

Forlì-  
Cesena

Perugia

# Our segments

Our leading natural refrigerant, energy efficiency and energy transition technologies transform the HVACR industry.



## COOLING

Our chillers are designed to operate efficiently with all refrigerants, generating cold water for climatization or industrial processes.



## REFRIGERATION

Our commercial and industrial refrigeration systems are designed for high performance, quality, reliability and carbon footprint reduction through the use of natural refrigerants Ammonia and CO<sub>2</sub>.



## HEATING

Our high efficiency heat pump range using natural refrigerant CO<sub>2</sub> is a simple-to use, elegant solution for applications requiring high quantities of sanitary hot water.

# We are driven by strong values to create a better and more sustainable world



## ENVIRONMENT

Buildings consume 40% of the energy used in the developed world. HVACR systems use 60% of the energy in buildings. Our high efficiency solutions are central to reducing global warming, and we strive every day to help our customers reduce their carbon footprint by using natural refrigerants.



## INNOVATION

Always leading. From pioneering the efficient and safe use of natural refrigerants to helping the industry move away from gas heat towards systems that use electricity.



## COMMUNITIES

We are a European industrial champion, building clean factories that support new jobs, growth and expansion to new markets.



## DIVERSITY & INCLUSION

At Enex Technologies we ensure that every colleague feels respected, valued and motivated to support our customers, every day.

THE EMICON

# LABS

## CLIMATIC ROOMS

EMICON has **climatic rooms** and **testing stations** where units produced are subject to strict **functional** and **performance** tests, with the possibility of simulating the real design climatic conditions. A double hydronic circuit (hot and cold) allows to carry out **operation tests on all types** of units, both for IT Cooling and hydronic units, packaged, 2 or 4 pipes, air cooled, water cooled and split, up to a cooling capacity of 1500 kW.

It is possible, for our customers, to attend the functioning and performance test. Thanks to some webcams, it is possible to **remotely attend the test**.

## CHARACTERISTICS

The climatic room is an environment inside of which, by means of auxiliary and heat recovery systems, we create a **controlled microclimate** in terms of air **temperature** and **humidity**, where the heat transfer fluids are treated according to the specific characteristics of the unit.

The types of units that can be tested are **air or water cooled units**, available as **chiller** or **reversible heat pump** versions according to **EN14511** standard.

The operating limits of fluid temperature can vary between **-5°C** and **65°C**. The ambient temperature (inside the room) can reach a maximum of 52°C for summer operation and a minimum of -7°C for winter cycle.

## CLOSE CONTROL UNITS

EMICON's Laboratory allows the **performance test** of chilled water and air cooled direct expansion **close control units**, with the possibility to simulate climatic conditions from 15°C to 35°C.

## PROPANE

We recently built a the test area **exclusively** dedicated to chillers and heat pumps operating with natural **Propane refrigerant (R290)**, making us able to carry out performance and functional tests of units with a cooling capacity up to 700 kW both in cooling only and in winter cycle reversible configurations. The use of **ATEX** components, refrigerant leak detection systems, connected to acoustic signals and forced-type exhaust systems guarantee a **high safety degree** in this area.



# LEGEND



Air cooled



Water cooled



2-pipe unit



4-pipe unit



Indoor installation



Outdoor installation



Units with a ground source



Remote condensing



High efficiency



Silenced version



Super-silenced version



Ultra-silenced version



Scroll Compressors



Scroll inverter Compressors



E.V.I Scroll Compressors



Screw Compressors



Screw Inverter Compressors



Heating only



Reversible unit



Multipurpose Unit



Free cooling



Outdoor temperature +43°C



Outdoor temperature -20°C



Domestic hot water +60°C



Domestic hot water +65°C



Domestic hot water +78°C



AC Fans



EC Fans



Centrifugal fan with AC motor



Centrifugal fan with EC motor



Plug-fan with AC motor



Plug-fan with EC motor



Plate exchanger

# SERIES

LSA/HP



LHi



LHA



LHE



PAE N



PAH VS



LZT



LZTi



WZT



WZA



WHA



WHK



LHi/P4



LHA/P4



LHE/P4



GPE N



GPH VS



LZT/P4



# FEATURES

# REFRIGERANT

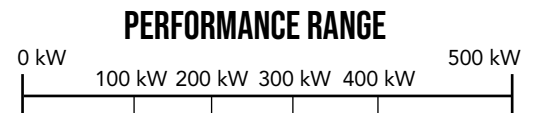

R410A



R410A



R410A



R454B



R410A R454B



R513A



R410A



R410A



R410A



R410A



R410A



R134a



R410A



R410A



R454B



R410A R454B



R410A R454B



R410A



# LSA/HP

## HIGH EFFICIENCY AIR TO WATER HEAT PUMPS

Heating capacity from 6 kW to 44 kW

R410A

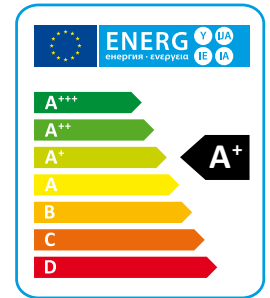

The LSA/HP water chiller range has been designed for small and medium residential and commercial applications. They are suitable for generating chilled water at 7°C, commonly used in applications with fan coils and/or air handling units. LSA/HP water chillers have high operating efficiencies and are quiet in operation. Differing versions and a wide range of accessories, enable the optimal solution to be selected.

### VERSIONS

**HP** - Reversible version

## TECHNICAL DATA

LSA/HP		06	08	10	14	16	21	26	31	36	41
Cooling capacity (EN14511) <sup>(1)</sup>	kW	5,7	7,5	8,5	14,0	15,5	20,5	26,6	30,0	33,0	39,0
Total input power (EN14511) <sup>(1)</sup>	kW	1,9	2,5	2,8	4,7	5,7	6,8	8,8	10,5	11,8	13,8
EER (EN14511) <sup>(1)</sup>	W/W	3,0	3,0	3,0	2,9	2,7	3,0	3,0	2,9	2,8	2,8
Heating capacity (EN14511) <sup>(2)</sup>	kW	5,9	7,7	9,2	14,9	17,2	22,0	29,5	33,5	36,5	44,4
Total input power (EN14511) <sup>(2)</sup>	kW	1,5	2,0	2,3	3,9	4,3	5,2	6,8	8,2	9,0	10,7
COP (EN14511) <sup>(2)</sup>	W/W	3,9	3,9	4,0	3,8	4,0	4,3	4,3	4,1	4,1	4,2
Energy Class <sup>(3)</sup>		A+	A+	A+	A+	A+	A+	A+	A+	A+	A+
SCOP <sup>(3)</sup>	kWh/kWh	3,38	3,32	3,40	3,35	3,23	3,38	3,21	3,21	3,21	3,29
$\eta_{s,h}$ <sup>(3)</sup>	%	132,2	129,8	132,9	131,1	126,2	132,3	125,4	125,4	125,5	128,4
Power supply	V/Ph/Hz	230/1/50	230/1/50	230/1/50	400/3+N/50	400/3+N/50	400/3+N/50	400/3+N/50	400/3+N/50	400/3+N/50	400/3+N/50
Peak current	A	60,6	68,0	99,0	66,0	77,0	96,8	119,8	120,6	142,6	176,6
Max input current	A	13,4	18,1	23,0	13,3	17,0	17,8	23,8	27,6	33,6	36,6
Air flow	m <sup>3</sup> /h	2.800	3.350	3.150	7.200	7.000	8.500	8.500	10.800	10.800	10.800
Fans	n°/kW	1 x 0,12	1 x 0,2	1 x 0,2	2 x 0,2	2 x 0,2	2 x 0,2	2 x 0,2	2 x 0,5	2 x 0,5	2 x 0,5
Compressors / Circuits	n°/n°	1 / 1	1 / 1	1 / 1	1 / 1	1 / 1	1 / 1	1 / 1	1 / 1	1 / 1	1 / 1
Refrigerant		R410A	R410A	R410A	R410A	R410A	R410A	R410A	R410A	R410A	R410A
Global warming potential (GWP)		2088	2088	2088	2088	2088	2088	2088	2088	2088	2088
Refrigerant charge	kg	3,0	4,2	3,7	3,7	5,0	7,3	8,0	6,5	6,5	8,0
Equivalent CO <sub>2</sub> charge	t	6,3	8,8	7,7	7,7	10,4	15,2	16,7	13,6	13,6	16,7
Sound power <sup>(4)</sup>	dB (A)	68	68	68	69	69	74	74	79	79	79
Sound pressure <sup>(5)</sup>	dB (A)	37	37	37	38	38	43	43	47	47	47
Water pump input power	kW	0,2	0,2	0,2	0,5	0,5	0,6	0,6	0,9	0,9	1,3
Pump available static pressure <sup>(1)</sup>	kPa	56,7	56,5	45,9	109,3	109,3	136,8	79,2	96,4	41,2	170,1
Water tank volume	l	30	30	30	45	45	45	45	135	135	135

Performances are referred to the following conditions:

(1)Cooling: ambient temperature 35°C; water temperature 12/7°C.

(2)Heating: ambient temperature 7°C (DB), 6°C (WB); water temperature 30/35°C.

(3) Average conditions, low temperature, variable - Reg EU 811/2013

(4) Sound power level in accordance with ISO 3744 (LS-Version).

(5) Sound pressure level at 10 mt from the unit in free field conditions in accordance with ISO 3744. (LS-Version).

## OPERATION LIMITS

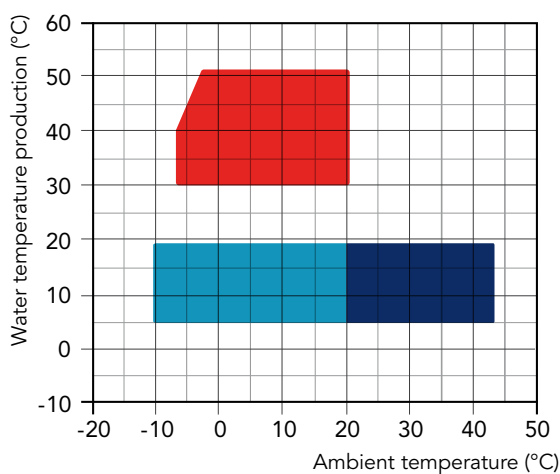

- Heating mode
- Cooling mode with cond. press. contr.
- Cooling mode without cond. press. contr.

## COMPONENTS

### FRAME

All LSA/HP units are made from hot-galvanised sheet steel, painted with polyurethane powder enamel and stoved at 180°C to provide maximum protection against corrosion. The frame is self-supporting with removable panels. All screws and rivets used are made from stainless steel. The standard colour of the units is RAL 9018.

### REFRIGERANT CIRCUIT

The refrigerant utilised is R410A. The refrigerant circuit is assembled using internationally recognised brand name components with all brazing and welding being performed in accordance with ISO 97/23. The refrigerant circuit includes: sight glass, filter drier, reversing valve (for reversible version only), one way valve (for reversible version only), liquid receiver (for reversible version only), Schraeder valves for maintenance and control and pressure safety device (for compliance with PED regulations).

### COMPRESSOR

For models 06 and 08, rotary type compressors are used. For all other models the compressors are of the scroll type. All compressors are fitted with a crankcase heater and each compressor has a klixon embedded in the motor winding for thermal overload protection. They are mounted in a separate compartment within the casing in order to isolate them from the condenser air stream. The crankcase heater is always energised when the compressor is in stand-by. Access to the compressor compartment is by removal of a front panel and, because they are isolated from the main airstream, maintenance of the compressors is possible whilst the unit is operating.

### CONDENSER

The condenser is made from 3/8" copper pipes and 0,1mm thick aluminium fins with the tubes being mechanically expanded into the aluminium fins in order to maximise heat transfer. Furthermore, the condenser design guarantees a low air side pressure drop thus enabling the use of low rotation speed (and hence low noise emission) fans. The condensers can be protected by a metallic filter that is available as an accessory.

### FANS

The fans are direct drive axial type with aluminium aerofoil blades, are statically and dynamically balanced and are supplied complete with a safety fan guard complying with the requirements of EN 60335. They are fixed to the unit frame via rubber anti-vibration mountings. The electric motors are 6 pole type rotating at approximately 900 rpm. The motors are fitted with integrated thermal overload protection and have a moisture protection rating of IP 54.

### EVAPORATORS

The evaporator is a braze welded, plate type heat exchanger, manufactured from AISI 316 stainless steel. Utilisation of this type of exchanger results in a massive reduction of the refrigerant charge of the unit compared to a traditional shell-in-tube evaporator. A further advantage is a reduction in the overall dimensions of the unit. The evaporators are factory insulated with flexible close cell material and can be fitted with an antifreeze heater (accessory). Each evaporator is fitted with a temperature sensor on the discharge water side for antifreeze protection.

### MICROPROCESSOR

All units are supplied with microprocessor controls loaded with ACTIVE auto-adaptive strategy. The microprocessor controls the following functions: control of the water temperature, antifreeze protection, compressor timing, compressor automatic starting sequence, alarm reset, volt free contact for remote general alarm, alarms and operation LED's. If required (available as an option), the microprocessor can be configured in order for it to connect to a site BMS system thus enabling remote control

and management. The Hidros technical department can discuss and evaluate, in conjunction with the customer, solutions using MODBUS protocols. The autoadaptive control system ACTIVE is an advanced strategy that continuously monitors the temperature of the inlet and outlet water thereby determining the variation of the building thermal load. By then adjusting the outlet water temperature set point the compressor start/stop cycle can be accurately controlled thus optimizing the unit efficiency and maximizing the operational life of the units component's. Use of ACTIVE auto-adaptive Control enables the minimum water content to be reduced from the traditional 12-15 l/kw to 5 l/kw. A further benefit of the reduced water requirement is that units can be used in installations without a buffer tank thereby reducing the space requirements, thermal losses and costs.

### ELECTRIC ENCLOSURE

The enclosure is manufactured in order to comply with the requirements of the electromagnetic compatibility standards CEE 2014/35 and 2014/30. Access to the enclosure is achieved by removing the front panel of the unit. The following components are supplied as standard on all units: main switch, thermal overloads (protection of pumps and fans), compressor fuses, control circuit automatic breakers, compressor contactors, fan contactors and pump contactors. The terminal board has volt free contacts for remote ON-OFF, summer / winter change over (reversible versions only) and general alarm. For all three phase units, a sequence relay that disables the power supply in the event that the phase sequence is incorrect (scroll compressors can be damaged if they rotate in the wrong direction), is fitted as standard.

### CONTROL AND PROTECTION DEVICES

All units are supplied with the following control and protection devices: Return water temperature sensor installed on the return water line from the building, antifreeze protection sensor installed on the outlet water temperature high pressure switch with manual reset, low pressure switch with automatic reset, high pressure safety valve, compressor thermal overload protection, fans thermal overload protection and flow switch.

## VERSIONS

### Reversible version (HP)

The reversible versions are provided with a 4 way reversing valve and are designed to produce hot water up to a temperature of 48°C. They are always supplied with a liquid receiver and a second thermostatic valve in order to optimize the efficiency of the refrigerant cycle in heating and in cooling. The microprocessor controls defrost automatically (when operating in low ambient conditions) and also the summer/winter change over.

## ACCESSORIES

LSA/HP		06	08	10	14	16	21	26	31	36	41
Main switch		-	-	-	●	●	●	●	●	●	●
Flow switch		-	●	●	●	●	●	●	●	●	●
Microprocessor control		-	●	●	●	●	●	●	●	●	●
General alarm digital output		-	●	●	●	●	●	●	●	●	●
Remote on/off digital input		-	●	●	●	●	●	●	●	●	●
Liquid line solenoid valve	VSLI	○	○	○	○	○	○	○	○	○	○
LS low noise version	LS00	○	○	○	○	○	○	○	○	○	○
Fans regulation by phase cut	DCCF	○	○	○	○	○	○	○	○	○	○
Rubber anti-vibration mounts	KAVG	○	○	○	○	○	○	○	○	○	○
Spring anti-vibration mounts	KAVM	○	○	○	○	○	○	○	○	○	○
Electronic soft starter	DSSE	-	-	-	○	○	○	○	○	○	○
Evaporator antifreeze heater (basic version only)	RAEV	○	○	○	○	○	○	○	○	○	○
Antifreeze Kit (only for A version)	RAES	○	○	○	○	○	○	○	○	○	○
Refrigerant circuit pressure gauges	MAML	○	○	○	○	○	○	○	○	○	○
Condensate discharge drip tray *	BRCA	○	○	○	○	○	○	○	○	○	○
Hydraulic kit pump + tank (A1ZZ)	A1ZZ	○	○	○	○	○	○	○	○	○	○
Hydraulic kit pump no tank(A1NT)	A1NT	○	○	○	○	○	○	○	○	○	○
Remote control panel	PCRL	○	○	○	○	○	○	○	○	○	○
Serial interface card RS485	INSE	○	○	○	○	○	○	○	○	○	○
Electronic thermostatic valve	VTEE	○	○	○	○	○	○	○	○	○	○

\* Condensate discharge drip tray with antifreeze heater (Only for versions HP)

● Standard, ○ Optional, - Not available.

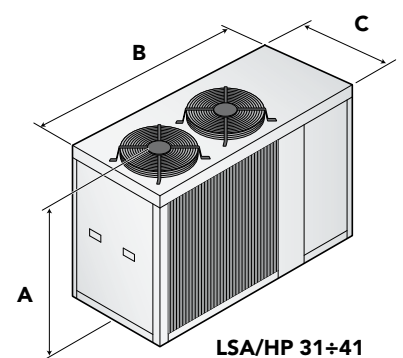
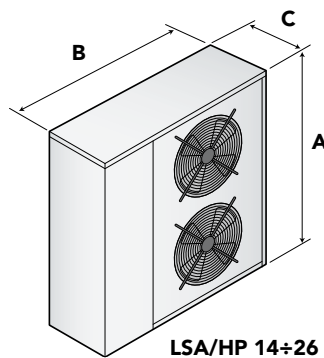
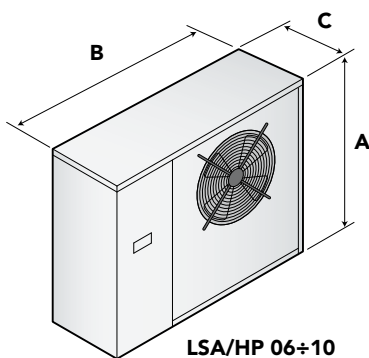

Mod.	A (mm)	B (mm)	C (mm)	kg
<b>06/06A</b>	989	1157	380	95/148
<b>08/08A</b>	989	1157	380	104/163
<b>10/10A</b>	989	1157	380	118/179
<b>14/14A</b>	1324	1245	423	127/207
<b>16/16A</b>	1324	1245	423	133/212

Mod.	A (mm)	B (mm)	C (mm)	kg
<b>21/21A</b>	1424	1508	473	188/267
<b>26/26A</b>	1424	1508	473	209/286
<b>31/31A</b>	1406	1910	950	330/440
<b>36/36A</b>	1406	1910	950	345/495
<b>41/41A</b>	1406	1910	950	360/520

# LHi

## HIGH EFFICIENCY AIR TO WATER HEAT PUMPS WITH INVERTER COMPRESSOR AND AXIAL FANS

Heating capacity from 51 kW to 270 kW

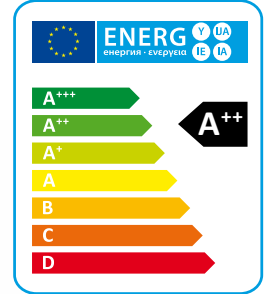

The LHi series high efficiency air/water heat pumps are particularly suitable for applications with radiant panel heating systems or for those applications where maximum efficiency in heating mode is required. The units have been specifically designed to have the best efficiency in heating mode, they can operate up to outdoor temperatures of -20°C and produce water up to a temperature of 60°C. All models are also equipped with reverse cycle valve for winter defrosting function; the HH versions are designed for hot water production only and are suitable for tax deductions in countries where there are specific regulations for the use of heat pumps as heat generators. The RV versions are capable of producing chilled water. The XL versions also have an extremely low noise level thanks to the use of a special floating vibration dampening system that allows a noise reduction of about 6-8 dB(A) (optional).

### VERSIONS

- HH** Heating only.
- RV** Reversible heating/cooling.
- SE** Standard efficiency, EC fans.
- LS** Low noise.
- XL** Super low noise.
- P2U** 2 pipe systems without domestic hot water production.
- P2S** 2 pipe systems with domestic hot water production by external 3 way valve.

## TECHNICAL DATA

Heating only version (HH)

SE/LS/HH - P2S/P2U		532	632	742	862	912	1052	1222	1534	1654	1854	1964	2254	2554
Heating capacity (EN14511) <sup>(1)</sup>	kW	53,3	61,8	74,2	85,1	90,9	102,5	118,3	129,0	145,3	165,2	188,7	223,4	269,6
Total input power (EN14511) <sup>(1)</sup>	kW	13,2	14,7	18,7	20,0	22,1	24,9	28,5	31,2	34,0	39,1	44,8	55,1	65,8
COP (EN14511) <sup>(1)</sup>	W/W	4,04	4,19	3,97	4,25	4,11	4,12	4,15	4,14	4,27	4,23	4,21	4,06	4,10
Energy Class <sup>(2)</sup>		A++	A++	A++	A++	A++	A++	A++	A++	A++	A++	A++	A++	A++
SCOP <sup>(2)</sup>	kWh/kWh	3,88	3,93	3,90	3,98	3,92	3,93	3,88	3,95	3,93	4,00	3,90	3,88	3,88
$\eta_{s,h}$ <sup>(2)</sup>	%	152	154	153	156	154	154	152	155	154	157	153	152	152
Sound power level <sup>(3)</sup>	dB (A)	81	81	83	83	83	84	85	86	87	87	87	89	89
Sound pressure level <sup>(4)</sup>	dB (A)	49	49	51	51	51	52	53	54	55	55	55	57	57
Power supply	V/Ph/Hz	400/3/50												
Compressors / Circuits	n° / n°	2 / 1	2 / 1	2 / 1	2 / 1	2 / 1	2 / 1	2 / 1	4 / 2	4 / 2	4 / 2	4 / 2	4 / 2	4 / 2
Fans	n°	2	2	2	3	3	3	4	2	3	3	3	4	4
Refrigerant		R410A	R410A	R410A	R410A	R410A	R410A	R410A	R410A	R410A	R410A	R410A	R410A	R410A
Refrigerant charge	kg	10,4	14,7	14,7	17,5	17,5	22,3	22,7	32,6	39,8	39,8	45,5	50,9	59,0
Global warming potential (GWP)		2088	2088	2088	2088	2088	2088	2088	2088	2088	2088	2088	2088	2088
Equivalent CO <sub>2</sub> charge	t	21,8	30,7	30,7	36,5	36,5	46,5	47,4	68,0	83,2	83,2	95,0	106,2	123,1
Water tank volume	l	140	300	300	500	500	500	500	300	500	500	500	500	500

SE/XL/HH - P2S/P2U		532	632	742	862	912	1052	1222	1534	1654	1854	1964	2254	2554
Heating capacity (EN14511) <sup>(1)</sup>	kW	51,8	59,4	77,1	82,9	87,8	101,9	114,4	126,9	142,2	163,6	184,6	224,7	267,2
Total input power (EN14511) <sup>(1)</sup>	kW	12,8	14,3	18,6	19,8	21,5	24,2	27,7	30,1	32,3	37,7	42,9	53,3	63,8
COP (EN14511) <sup>(1)</sup>	W/W	4,04	4,15	4,15	4,20	4,08	4,21	4,13	4,22	4,41	4,35	4,31	4,22	4,19
Energy Class <sup>(2)</sup>		A++	A++	A++	A++	A++	A++	A++	A++	A++	A++	A++	A++	A++
SCOP <sup>(2)</sup>	kWh/kWh	3,95	4,10	4,08	4,13	4,10	4,03	4,00	4,18	4,28	4,25	4,18	4,15	4,13
$\eta_{s,h}$ <sup>(2)</sup>	%	155	161	160	162	161	158	157	164	168	167	164	163	162
Sound power level <sup>(3)</sup>	dB (A)	76	77	78	78	79	79	80	80	80	80	82	83	84
Sound pressure level <sup>(4)</sup>	dB (A)	44	45	46	46	47	47	48	48	48	48	50	51	52
Power supply	V/Ph/Hz	400/3/50												
Compressors / Circuits	n° / n°	2 / 1	2 / 1	2 / 1	2 / 1	2 / 1	2 / 1	2 / 1	4 / 2	4 / 2	4 / 2	4 / 2	4 / 2	4 / 2
Fans	n°	2	2	2	3	3	3	4	2	3	3	3	4	4
Refrigerant		R410A	R410A	R410A	R410A	R410A	R410A	R410A	R410A	R410A	R410A	R410A	R410A	R410A
Refrigerant charge	kg	10,4	14,7	16,3	17,5	17,5	22,3	22,7	32,6	39,8	39,8	32,5	50,9	59,0
Global warming potential (GWP)		2088	2088	2088	2088	2088	2088	2088	2088	2088	2088	2088	2088	2088
Equivalent CO <sub>2</sub> charge	t	21,8	30,7	34,1	36,5	36,5	46,5	47,4	68,0	83,2	83,2	67,8	106,2	123,1
Water tank volume	l	140	300	300	500	500	500	500	300	500	500	500	500	500

Performances are referred to the following conditions:

(1) Heating: Ambient temperature 7°C DB, 6°C WB, water temperature 30/35°C.

(2) Average conditions, low temperature, variable - Reg EU 811/2013

(3) Sound power level in accordance with ISO 3744.

(4) Sound pressure level at 10 mt from the unit in free field conditions in accordance with ISO 3744.

Reversible heating/cooling version (RV)

SE/LS/RV - P2S/P2U		532	632	742	862	912	1052	1222	1534	1654	1854	1964	2254	2554
Heating capacity (EN14511) <sup>(1)</sup>	kW	53,3	61,8	74,2	85,1	90,9	102,5	118,3	129,0	145,3	165,2	188,7	223,4	269,6
Total input power (EN14511) <sup>(1)</sup>	kW	13,2	14,7	18,7	20,0	22,1	24,9	28,5	31,2	34,0	39,1	44,8	55,1	65,8
COP (EN14511) <sup>(1)</sup>	W/W	4,04	4,19	3,97	4,25	4,11	4,12	4,15	4,14	4,27	4,23	4,21	4,06	4,10
Energy Class <sup>(2)</sup>		A++	A++	A++	A++	A++	A++	A++	A++	A++	A++	A++	A++	A++
SCOP <sup>(2)</sup>	kWh/kWh	3,88	3,93	3,90	3,98	3,92	3,93	3,88	3,95	3,93	4,00	3,90	3,88	3,88
η <sub>s,h</sub> <sup>(2)</sup>	%	152	154	153	156	154	154	152	155	154	157	153	152	152
Cooling capacity (EN14511) <sup>(3)</sup>	kW	49,32	57,71	68,9	78,87	83,19	95,32	109,3	112,8	129,4	146,3	162,5	197,4	230,6
Total input power (EN14511) <sup>(3)</sup>	kW	16,42	18,47	24,48	25,78	28,18	31,81	36,3	40,3	42,6	50,2	57,0	69,5	84,6
EER (EN14511) <sup>(3)</sup>	W/W	3,00	3,12	2,81	3,06	2,95	3,00	3,01	2,80	3,04	2,91	2,85	2,84	2,72
Sound power level <sup>(4)</sup>	dB (A)	81	81	83	83	83	84	85	86	87	87	87	89	89
Sound pressure level <sup>(5)</sup>	dB (A)	49	49	51	51	51	52	53	54	55	55	55	57	57
Power supply	V/Ph/Hz	400/3/50												
Compressors / Circuits	n° / n°	2 / 1	2 / 1	2 / 1	2 / 1	2 / 1	2 / 1	2 / 1	4 / 2	4 / 2	4 / 2	4 / 2	4 / 2	4 / 2
Fans	n°	2	2	2	3	3	3	4	2	3	3	3	4	4
Refrigerant		R410A												
Refrigerant charge	kg	10,4	14,7	14,7	17,5	17,5	22,3	22,7	32,6	39,8	39,8	45,5	50,9	59,0
Global warming potential (GWP)		2088												
Equivalent CO <sub>2</sub> charge	t	21,8	30,7	30,7	36,5	36,5	46,5	47,4	68,0	83,2	83,2	95,0	106,2	123,1
Water tank volume	l	140	300	300	500	500	500	500	300	500	500	500	500	500

Performances are referred to the following conditions:

- (1) Heating: Ambient temperature 7°C DB, 6°C WB, water temperature 30/35°C.
- (2) Average conditions, low temperature, variable - Reg EU 811/2013.

(3) Cooling: ambient air temperature 35°C, evaporator water temperature in/out 12/7 °C.

(4) Sound power level in accordance with ISO 3744.

(5) Sound pressure level at 10 mt from the unit in free field conditions in accordance with ISO 3744.

SE/XL/RV - P2S/P2U		532	632	742	862	912	1052	1222	1534	1654	1854	1964	2254	2554
Heating capacity (EN14511) <sup>(1)</sup>	kW	51,8	59,4	77,1	82,9	87,8	101,9	114,4	126,9	142,2	163,6	184,6	224,7	267,2
Total input power (EN14511) <sup>(1)</sup>	kW	12,8	14,3	18,6	19,8	21,5	24,2	27,7	30,1	32,3	37,7	42,9	53,3	63,8
COP (EN14511) <sup>(1)</sup>	W/W	4,04	4,15	4,15	4,20	4,08	4,21	4,13	4,22	4,41	4,35	4,31	4,22	4,19
Energy Class <sup>(2)</sup>		A++	A++	A++	A++	A++	A++	A++	A++	A++	A++	A++	A++	A++
SCOP <sup>(2)</sup>	kWh/kWh	3,95	4,10	4,08	4,13	4,10	4,03	4,00	4,18	4,28	4,25	4,18	4,15	4,13
$\eta_{s,h}$ <sup>(2)</sup>	%	155	161	160	162	161	158	157	164	168	167	164	163	162
Cooling capacity (EN14511) <sup>(3)</sup>	kW	48,0	55,9	70,4	76,4	80,4	91,9	105,7	109,4	124,9	140,1	154,6	198,5	231,8
Total input power (EN14511) <sup>(3)</sup>	kW	16,3	18,4	22,7	25,6	28,1	32,1	36,2	38,9	40,8	49,4	56,0	62,9	77,9
EER (EN14511) <sup>(3)</sup>	W/W	2,86	2,96	3,00	2,90	2,79	2,80	2,84	2,68	2,93	2,73	2,67	2,97	2,83
Sound power level <sup>(4)</sup>	dB (A)	76	77	78	78	79	79	80	80	80	80	82	83	84
Sound pressure level <sup>(5)</sup>	dB (A)	44	45	46	46	47	47	48	48	48	48	50	51	52
Power supply	V/Ph/Hz	400/3/50												
Compressors / Circuits	n° / n°	2 / 1	2 / 1	2 / 1	2 / 1	2 / 1	2 / 1	2 / 1	4 / 2	4 / 2	4 / 2	4 / 2	4 / 2	4 / 2
Fans	n°	2	2	2	3	3	3	4	2	3	3	3	4	4
Refrigerant		R410A	R410A	R410A	R410A	R410A	R410A	R410A	R410A	R410A	R410A	R410A	R410A	R410A
Refrigerant charge	kg	10,4	14,7	16,3	17,5	17,5	22,3	22,7	32,6	39,8	39,8	32,5	50,9	59,0
Global warming potential (GWP)		2088	2088	2088	2088	2088	2088	2088	2088	2088	2088	2088	2088	2088
Equivalent CO <sub>2</sub> charge	t	21,8	30,7	34,1	36,5	36,5	46,5	47,4	68,0	83,2	83,2	67,8	106,2	123,1
Water tank volume	l	140	300	300	500	500	500	500	300	500	500	500	500	500

Performances are referred to the following conditions:

(1) Heating: Ambient temperature 7°C DB, 6°C WB, water temperature 30/35°C.

(2) Average conditions, low temperature, variable - Reg EU 811/2013.

(3) Cooling: ambient air temperature 35°C, evaporator water temperature in/out 12/7 °C.

(4) Sound power level in accordance with ISO 3744.

(5) Sound pressure level at 10 mt from the unit in free field conditions in accordance with ISO 3744.

## COMPONENTS

### FRAME

All units are made from hot-galvanised sheet steel, painted with polyurethane powder enamel and stoved at 180°C to provide maximum protection against corrosion. The frame is self-supporting with removable panels. All screws and rivets used are made from stainless steel. The standard colour of the units is RAL9018.

### REFRIGERANT CIRCUIT

The refrigerant utilised is R410A. The refrigerant circuit is assembled using internationally recognised brand name components with all brazing and welding being performed in accordance with ISO 97/23. The refrigerant circuit includes: sight glass, filter drier, two thermal expansion valves (one for cooling mode, one for heating mode) with external equalizer, 4 way reversing valve, check valves, liquid receiver, Schrader valves for maintenance and control, pressure safety device (for compliance with PED regulations).

### COMPRESSORS

The compressors used are three-phase scroll type BPM (brushless permanent magnet) high efficiency, controlled by an Inverter, supplied with a specific design that increases the efficiency of the refrigerant cycle in very low ambient temperature conditions. All sizes use compressors in tandem configuration, and are all optimized for heat pump applications for high seasonal efficiency (SCOP). The compressors are all supplied with electrical resistance and thermal overload protection. They are all mounted in a dedicated compartment to keep them separated from the airflow. The electric heater is always powered when the compressor is in stand by mode. Maintenance is possible through the front panel of the unit which allows to reach the compressors even when the machine is running.

### SOURCE HEAT EXCHANGER

The source heat exchanger is made from copper pipes and aluminium fins. Dimensioning of the copper pipes and the aluminium fins is optimized in order to obtain excellent performance. The tubes are mechanically expanded into the fins in order to maximise heat transfer. Furthermore, the design guarantees a low air side pressure drop thus enabling the use of low rotation speed (and hence low noise) fans. All heat exchangers are supplied standard with fins hydrophilic coating.

### HIGH EFFICIENCY E.C. AXIAL FANS (VECE)

High efficiency E.C. axial fans, supplied with Brushless DC electric motors electronically commutated (E.C. motors) able to grant the highest energy efficiency class (EFF1), according to the latest EU specifications, with the result of substantial energy consumption reduction for ventilation and noise reduction thanks to the new ultra efficient blade profiling. The fans are statically and dynamically balanced and supplied complete with a safety fan guard complying with the requirements of EN 60335. The fans are installed using a special steel profiled beam who minimize all vibrations and noise emitted. The average nominal rotation speed is 700 rpm. All units are fitted with a pressure transducer for the control of the evaporation/condensation pressure. The motors are fitted with integrated thermal overload protection and have a moisture protection rating of IP54.

### MICROPROCESSORS

All units are supplied as standard complete with control panel. The microprocessor controls the following functions: control of the water temperature, antifreeze protection, compressor timing, compressor automatic starting sequence (For multiple compressors), alarm reset.

The control panel is supplied with display showing all operational icons. The microprocessor is set for automatic defrost (when operating in severe ambient conditions) and for summer/ winter change over (only for RV versions). The control also manages

the anti-legionella program, the integration with other heating sources (electric heaters, boilers, solar panels etc), the operation of a three port modulating valve (for diverting to DHW or heating) and both the heating circuit pump and the domestic hot water circuit pump. All units are set up for connection to a site BMS system thus enabling remote control and management.

### ELECTRIC ENCLOSURE

The enclosure is manufactured in order to comply with the requirements of the electromagnetic compatibility standards CEE EN60204. Access to electrical cabinet in quick and easy thanks to hinged panels. The following components are supplied as standard on all units: main switch, a sequence relay that disables the power supply in the event that the phase sequence is incorrect (scroll compressors can be damaged if they rotate in the wrong direction), thermal overloads (protection of pumps and fans), compressor fuses, control circuit automatic breakers, compressor contactors, fan contactors and pump contactors. The terminal board has volt free contacts for remote ON-OFF, Summer/ winter change over (heat pumps only) and general alarm.

### CONTROL AND PROTECTION DEVICES

All units are supplied with the following controls and protections: user water return temperature sensor, antifreeze protection temperature sensor installed on users water output, domestic hot water supply and return temperature sensors (only versions P2S), high pressure and low pressure automatic reset, compressor thermal protection, air fan, thermal protection, pressure transducer (used to optimize the defrost cycle and to adjust the fan speed depending on ambient conditions), flow switch. All units are also fitted with a temperature probe sensor with "Energy Saving" function, supplied in a separate plastic box, which can be used to stop the pump use during periods of stand-by, when the water temperature reaches the set point. Doing this the power consumption of the unit is strongly reduced.

### ELECTRONIC EXPANSION VALVE (VTEE)

The use of the electronic thermostatic valve is particularly suitable for units operating under very variable load conditions. The electronic expansion valve enables the maximum possible efficiency to be achieved by maximizing the evaporator heat exchange, minimizing the reaction time to load variations and optimizing the superheat. The use of the electronic thermostatic valve is particularly suitable for units operating under very variable load conditions.

## VERSIONS

### P2U Version

This is a two pipe version that can produce hot water for heating (HH heating only) and hot or cold water in the RV version. The RV is used with two pipe water based change-over systems. It is not able to produce domestic hot water.

### P2S Version

This is a two pipe version that can, in addition to producing hot water for heating (HH version) and hot and cold water in the RV version can also generate domestic hot water. The controller has dual heating set points (heating and DHW) and can also control a three port diverting valve that directs the DHW to the cylinder. DHW production has priority irrespective of the mode of operation of the unit. The unit is normally used with two pipe water based change-over systems.

**HH Version**

HH heating only versions are available in the P2U and P2S configuration only.

**RV Version**

This version uses 2 hydraulic connections and is able to produce hot water in winter and cold water in summer. The unit is combined with a 2-pipe system.

**SE Version**

Standard efficiency version, according to current standard. Unit equipped with EC fans.

**LS Version**

This version includes the complete acoustic insulation of the unit with compressor jackets and insulating material made with high density media and the interposition of heavy bitumen layer.

**XL Super low noise version**

All XL super silenced units are supplied equipped with a special vibration-damping system consisting of a floating basement placed upon the unit's frame, through the interposition of high-damping steel springs.

The compressors are housed on this floating base and are in turn fixed by means of rubber anti-vibration supports.

The enclosure is manufactured from galvanized steel sandwich panels that have a micro-perforated inner skin and a core of 30 mm thick, high density (25 kg/m<sup>3</sup>) soundproofing mat. The entire arrangement provides a double damping system and acoustic attenuation. The compressor refrigerant pipes are connected to the refrigerant circuit through "anaconda" flexible connections. Flexible connections are also used on the water pipework within the unit. The combination of these systems results in an overall noise reduction in the region of 6-8 dB(A) compared to units in standard configuration.

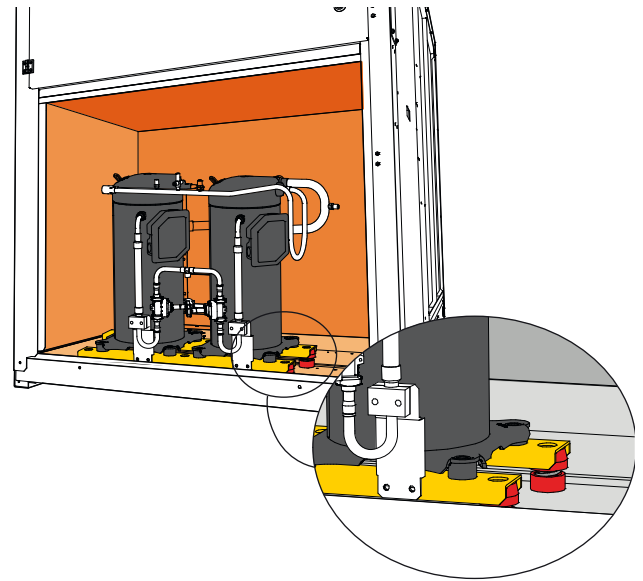
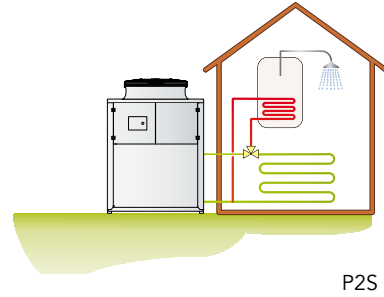
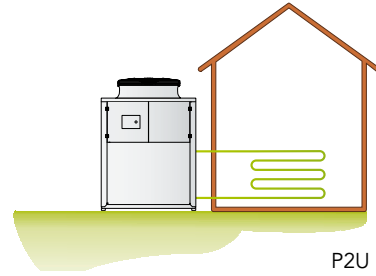

**OPERATION LIMITS**

**(SE versions)**

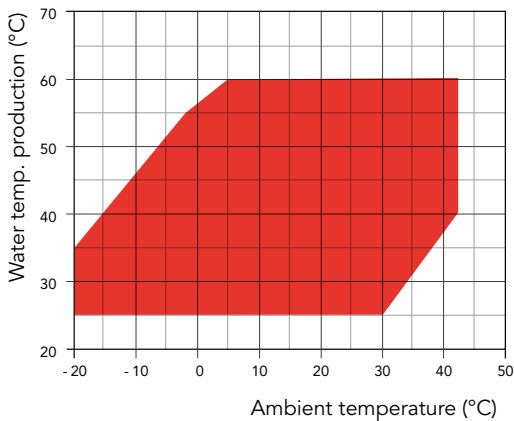

**(RV versions Only)**

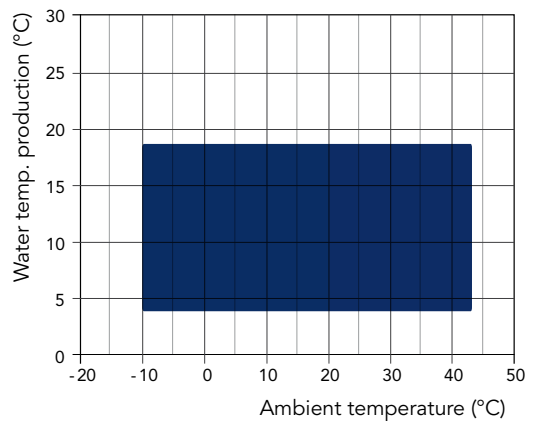

- Heating mode
- Cooling mode

## ACCESSORIES

LHi SE/HH-RV	P2S/P2U	532	632	742	862	912	1052	1222
Flow switch		●	●	●	●	●	●	●
"Floating frame" Technology - XL Version		●	●	●	●	●	●	●
E.C. fans - SE versions	<b>VECE</b>	●	●	●	●	●	●	●
Condensate discharge drip tray with antifreeze heater	<b>BRCA</b>	○	○	○	○	○	○	○
Antifreeze kit for 2 pipe units	<b>RAEV2</b>	○	○	○	○	○	○	○
Electronic soft starter	<b>DSSE</b>	○	○	○	○	○	○	○
Serial interface card RS485	<b>INSE</b>	●	●	●	●	●	●	●
Rubber anti-vibration mountings	<b>KAVG</b>	○	○	○	○	○	○	○
Remote control panel	<b>PCRL</b>	○	○	○	○	○	○	○
Electronic expansion valve	<b>VTEE</b>	●	●	●	●	●	●	●
Power factor correction system	<b>RICO</b>	○	○	○	○	○	○	○
Power factor correction system with soft starter	<b>RICSS</b>	○	○	○	○	○	○	○
Spring vibration dampers	<b>KAVM</b>	○	○	○	○	○	○	○
Coil protection grid	<b>GBPE</b>	○	○	○	○	○	○	○
Shut-off valve on compressor discharging side	<b>RDCO</b>	○	○	○	○	○	○	○
Shut-off valve on compressor suction side	<b>RHCO</b>	○	○	○	○	○	○	○
Hydraulic kit with one inverter pump	<b>A1VSU</b>	○	○	○	○	○	○	○
Hydraulic kit with one pump without tank	<b>A1NTU</b>	○	○	○	○	○	○	○
Hydraulic kit with one higher available pressure pump	<b>A1HPU</b>	○	○	○	○	○	○	○
Hydraulic kit with two pumps without tank	<b>A2NTU</b>	○	○	○	○	○	○	○
Hydraulic kit with tank and one inverter pump	<b>A1VVU</b>	○	○	○	○	○	○	○
Hydraulic kit with one pump with tank	<b>A1ZZU</b>	○	○	○	○	○	○	○
Hydraulic kit with tank and one higher available pressure pump	<b>A1HHU</b>	○	○	○	○	○	○	○
Hydraulic kit with two pumps with tank	<b>A2ZZU</b>	○	○	○	○	○	○	○
Buffer tank and pump for internal loop	<b>BUF4A</b>	○	○	○	○	○	○	○
Antifreeze kit in combination with A1VSU / A1NTU / A1HPU *	<b>KPU1</b>	○	○	○	○	○	○	○
Antifreeze kit in combination with A2NTU *	<b>KPU2</b>	○	○	○	○	○	○	○
Antifreeze kit in combination with pump and buffer tank *	<b>KPSU1</b>	○	○	○	○	○	○	○
Antifreeze kit in combination with pumps and buffer tank *	<b>KPSU2</b>	○	○	○	○	○	○	○

\* Includes accessory RAEV2

● Standard ○ Optional – Not available

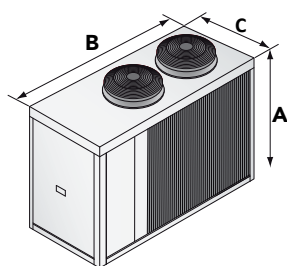

**SE/LS 532**  
**SE/XL 532**

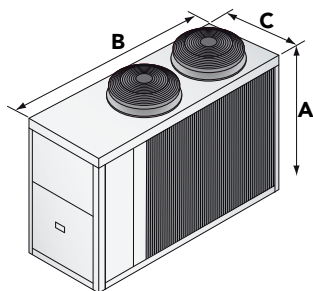

**SE/LS 632 - 742**  
**SE/XL 632**

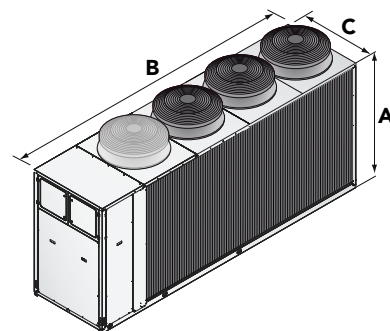

**SE/LS 862 - 912 - 1052 - 1222**  
**SE/XL 742 - 862 - 912 - 1052 - 1222**

		532	632	742	862	912	1052	1222
A (mm)	SE/LS	1690	1840	1840	1840	1840	1840	1840
B (mm)	SE/LS	2400	2905	2905	3905	3905	3905	3905
C (mm)	SE/LS	1145	1145	1145	1145	1145	1145	1145
kg	SE/LS	810	940	950	970	1270	1360	1410
A (mm)	SE/XL	1690	1840	1840	1840	1840	1840	1840
B (mm)	SE/XL	2400	2905	3905	3905	3905	3905	3905
C (mm)	SE/XL	1145	1145	1145	1145	1145	1145	1145
kg	SE/XL	830	960	970	990	1290	1380	1430

LHi SE/HH-RV	P2S/P2U	1534	1654	1854	1964	2254	2554
Flow switch		●	●	●	●	●	●
"Floating frame" Technology - XL Version		●	●	●	●	●	●
E.C. fans - SE versions	VECE	●	●	●	●	●	●
Condensate discharge drip tray with antifreeze heater	BRCA	○	○	○	○	○	○
Antifreeze kit for 2 pipe units	RAEV2	○	○	○	○	○	○
Electronic soft starter	DSSE	○	○	○	○	○	○
Serial interface card RS485	INSE	●	●	●	●	●	●
Rubber anti-vibration mountings	KAVG	○	○	○	○	○	○
Remote control panel	PCRL	○	○	○	○	○	○
Electronic expansion valve	VTEE	●	●	●	●	●	●
Power factor correction system	RICO	○	○	○	○	○	○
Power factor correction system with soft starter	RICSS	○	○	○	○	○	○
Spring vibration dampers	KAVM	○	○	○	○	○	○
Coil protection grid	GBPE	○	○	○	○	○	○
Shut-off valve on compressor discharging side	RDCO	○	○	○	○	○	○
Shut-off valve on compressor suction side	RHCO	○	○	○	○	○	○
Hydraulic kit with one inverter pump	A1VSU	○	○	○	○	○	○
Hydraulic kit with one pump without tank	A1NTU	○	○	○	○	○	○
Hydraulic kit with one higher available pressure pump	A1HPU	○	○	○	○	○	○
Hydraulic kit with two pumps without tank	A2NTU	○	○	○	○	○	○
Hydraulic kit with tank and one inverter pump	A1VVU	○	○	○	○	○	○
Hydraulic kit with one pump with tank	A1ZZU	○	○	○	○	○	○
Hydraulic kit with tank and one one higher available pressure pump	A1HHU	○	○	○	○	○	○
Hydraulic kit with two pumps with tank	A2ZZU	○	○	○	○	○	○
Buffer tank and pump for internal loop	BUF4A	○	○	○	○	○	○
Antifreeze kit in combination with A1VSU / A1NTU / A1HPU *	KPU1	○	○	○	○	○	○
Antifreeze kit in combination with A2NTU *	KPU2	○	○	○	○	○	○
Antifreeze kit in combination with pump and buffer tank *	KPSU1	○	○	○	○	○	○
Antifreeze kit in combination with pumps and buffer tank *	KPSU2	○	○	○	○	○	○

\* Includes accessory RAEV2

● Standard ○ Optional – Not available

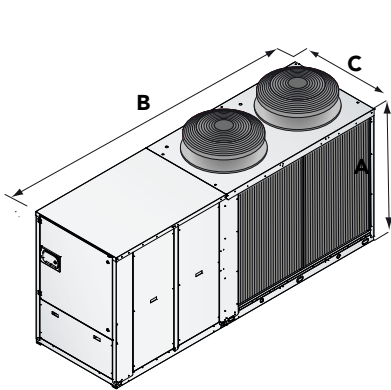

**SE/LS 1534**  
**SE/XL 1534**

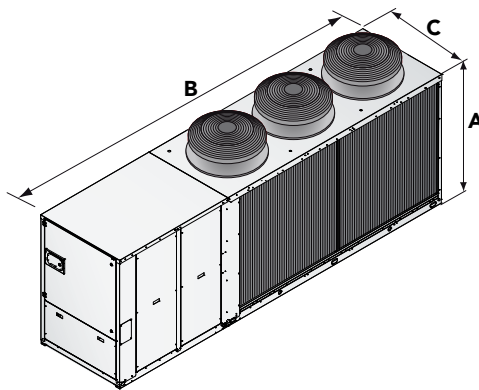

**SE/LS 1654 - 1854 - 1964**  
**SE/XL 1654 - 1854 - 1964**

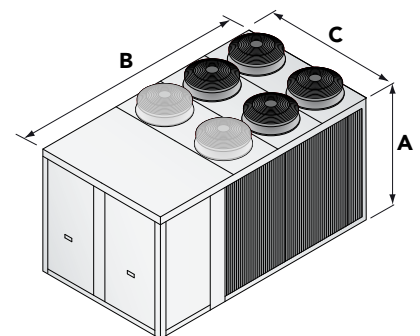

**SE/LS 2254 - 2554**  
**SE/XL 2254 - 2554**

		1534	1654	1854	1964	2254	2554
A (mm)	SE/LS	1890	1890	1890	1890	2350	2350
B (mm)	SE/LS	3695	4695	4695	4695	4205	4205
C (mm)	SE/LS	1145	1145	1145	1145	2190	2190
kg	SE/LS	1460	1810	1830	2130	2680	2720
A (mm)	SE/XL	1890	1890	1890	1890	2350	2350
B (mm)	SE/XL	3695	4695	4695	4695	4205	4205
C (mm)	SE/XL	1145	1145	1145	1145	2190	2190
kg	SE/XL	1480	1830	1850	2150	2700	2740

# LHA

## HIGH EFFICIENCY AIR TO WATER HEAT PUMPS EQUIPPED WITH SCROLL COMPRESSOR AND AXIAL FANS

Heating capacity from 22 kW to 460 kW

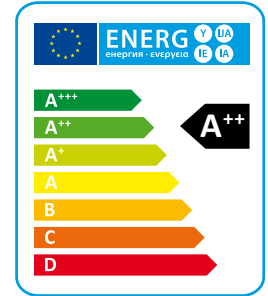

The LHA series of high efficiency heat pumps has been specifically designed for use with radiant floor heating systems or those applications where it is necessary to have maximum efficiency when heating. They have been optimized on heating mode, are able to produce water up to 60°C and can operate down to -20°C ambient temperature. All versions are supplied with reverse cycle valve used for winter defrost; the HH version is suitable for use in those countries that have support schemes for use of heat pump technology for heating. The RV versions are also able to produce cold water. The HH heating only versions is factory set and locked to operate only in heating mode whilst. The noise is extremely low thanks to the use of a special floating vibration damping system which allows a noise reduction of about 6-8 dB(A) (Optional).

### VERSIONS

- HH** Heating only.
- RV** Reversible heating/cooling.
- SA** Standard efficiency, AC fans.
- SE** Standard efficiency, EC fans.
- HA** High efficiency, AC fans.
- HE** High efficiency, EC fans.
- LS** Low noise.
- XL** Super low noise.
- P2U** 2 pipe systems without domestic hot water production.
- P2S** 2 pipe systems with domestic hot water production by external 3 way valve.

Heating only version (HH)

SA/LS/HH - P2S/P2U	242	292	402	432	492	592	702	802	902	1002	1202	1402
Heating capacity (EN14511) <sup>(1)</sup> kW	22,0	28,7	34,5	47,2	50,9	56,8	64,9	73,2	80,2	97,0	105,7	122,3
Total input power (EN14511) <sup>(1)</sup> kW	5,8	7,3	9,1	12,2	12,6	14,4	16,0	17,9	20,8	24,3	27,3	30,7
COP (EN14511) <sup>(1)</sup> W/W	3,83	3,93	3,80	3,86	4,04	3,94	4,06	4,10	3,86	4,00	3,87	3,98
Energy Class <sup>(2)</sup>	A+	A+	A+	A+	A+	A+	A+	A+	A+	A+	A+	A+
SCOP <sup>(2)</sup> kWh/kWh	3,27	3,58	3,41	3,34	3,48	3,54	3,43	3,47	3,42	3,50	3,39	3,50
η <sub>s,h</sub> <sup>(2)</sup> %	127,9	140,1	133,3	130,4	136,3	138,6	134,3	135,9	133,7	137,1	132,7	136,9
Sound power <sup>(3)</sup> dB (A)	75	75	75	75	77	77	77	78	79	82	83	85
Sound pressure <sup>(4)</sup> dB (A)	43	43	43	43	45	45	45	46	47	50	51	53
SE/LS/HH - P2S/P2U	242	292	402	432	492	592	702	802	902	1002	1202	1402
Heating capacity (EN14511) <sup>(1)</sup> kW	21,9	28,6	34,2	47,1	51,1	57,1	64,9	73,1	81,0	97,0	105,6	122,7
Total input power (EN14511) <sup>(1)</sup> kW	5,6	7,2	8,8	11,9	12,4	14,4	15,8	17,6	20,9	24,0	27,3	30,5
COP (EN14511) <sup>(1)</sup> W/W	3,92	3,95	3,87	3,95	4,13	3,97	4,10	4,15	3,88	4,04	3,87	4,02
Energy Class <sup>(2)</sup>	A+	A+	A+	A+	A+	A+	A+	A+	A+	A+	A+	A+
SCOP <sup>(2)</sup> kWh/kWh	3,40	3,66	3,53	3,46	3,59	3,62	3,68	3,71	3,63	3,71	3,64	3,73
η <sub>s,h</sub> <sup>(2)</sup> %	132,8	143,2	138,3	135,5	140,4	141,7	144,1	145,4	142,1	145,3	142,5	146,1
Sound power <sup>(3)</sup> dB (A)	74	74	75	75	77	77	77	78	79	82	83	85
Sound pressure <sup>(4)</sup> dB (A)	42	42	43	43	45	45	45	46	47	50	51	53
Power supply V/Ph/Hz	400/3+N/50						400/3/50					
Compressors / Circuits n° / n°	2 / 1	2 / 1	2 / 1	2 / 1	2 / 1	2 / 1	2 / 1	2 / 1	2 / 1	2 / 1	2 / 1	2 / 1
Fans n°	1	1	2	2	2	2	2	2	2	3	3	3
Refrigerant	R410A	R410A	R410A	R410A	R410A	R410A	R410A	R410A	R410A	R410A	R410A	R410A
Refrigerant charge kg	10,0	10,0	10,0	10,0	14,5	14,5	14,5	14,5	14,5	21,0	21,0	27,0
Global warming potential (GWP)	2088	2088	2088	2088	2088	2088	2088	2088	2088	2088	2088	2088
Equivalent CO <sub>2</sub> charge t	20,88	20,88	20,88	20,88	30,27	30,27	30,27	30,27	30,27	43,84	43,84	56,37
Water tank volume l	100	100	100	100	100	100	300	300	300	500	500	500

SA/LS/HH - P2S/P2U	1602	1802	2002	2302	2502	2504	3004	3204	3504	4004	4504	5004 *
Heating capacity (EN14511) <sup>(1)</sup> kW	136,0	157,3	169,0	196,6	215,0	211,8	226,1	258,8	330,6	357,4	393,3	431,7
Total input power (EN14511) <sup>(1)</sup> kW	34,6	40,3	43,4	51,5	60,4	58,2	64,8	71,9	85,2	93,8	103,0	116,4
COP (EN14511) <sup>(1)</sup> W/W	3,93	3,90	3,89	3,82	3,56	3,64	3,49	3,60	3,88	3,81	3,82	3,71
Energy Class <sup>(2)</sup>	A+	A+	A+	A+	A+	A+	A+	A+	A+	A+	A+	A+
SCOP <sup>(2)</sup> kWh/kWh	3,50	3,48	3,46	3,45	3,24	3,25	3,23	3,26	3,25	3,27	3,24	3,34
η <sub>s,h</sub> <sup>(2)</sup> %	137,0	136,1	135,5	134,8	126,5	127,1	126,1	127,2	127,0	127,8	126,4	130,4
Sound power <sup>(3)</sup> dB (A)	86	86	86	89	90	87	89	90	90	90	92	93
Sound pressure <sup>(4)</sup> dB (A)	54	54	54	57	58	55	57	58	58	58	60	61
SE/LS/HH - P2S/P2U	1602	1802	2002	2302	2502	2504	3004	3204	3504	4004	4504	5004 *
Heating capacity (EN14511) <sup>(1)</sup> kW	137,0	157,8	170,2	197,7	217,6	213,2	227,7	261,7	330,6	357,5	396,6	435,4
Total input power (EN14511) <sup>(1)</sup> kW	34,6	38,8	43,3	51,5	60,3	57,9	65,1	71,9	82,9	92,1	102,7	116,7
COP (EN14511) <sup>(1)</sup> W/W	3,96	4,07	3,93	3,84	3,61	3,68	3,50	3,64	3,99	3,88	3,86	3,73
Energy Class <sup>(2)</sup>	A+	A+	A+	A+	A+	A+	A+	A+	A+	A+	A+	A+
SCOP <sup>(2)</sup> kWh/kWh	3,68	3,77	3,72	3,74	3,63	3,54	3,49	3,46	3,52	3,57	3,63	3,58
η <sub>s,h</sub> <sup>(2)</sup> %	144,0	147,8	145,8	146,4	142,1	138,6	136,5	135,2	137,9	139,6	142,3	140,0
Sound power <sup>(3)</sup> dB (A)	86	86	86	89	90	87	89	90	90	90	92	93
Sound pressure <sup>(4)</sup> dB (A)	54	54	54	57	58	55	57	58	58	58	60	61
Power supply V/Ph/Hz	400/3/50											
Compressors / Circuits n° / n°	2 / 1	2 / 1	2 / 1	2 / 1	2 / 1	4 / 2	4 / 2	4 / 2	4 / 2	4 / 2	4 / 2	4 / 2
Fans n°	4	4	4	3	4	4	4	4	6	6	6	8
Refrigerant	R410A	R410A	R410A	R410A	R410A	R410A	R410A	R410A	R410A	R410A	R410A	R410A
Refrigerant charge kg	27,0	36,0	36,0	45,0	45,0	45,0	54,0	54,0	72,0	80,0	90,0	100,0
Global warming potential (GWP)	2088	2088	2088	2088	2088	2088	2088	2088	2088	2088	2088	2088
Equivalent CO <sub>2</sub> charge t	56,37	75,16	75,16	93,96	93,96	93,96	112,75	112,75	150,33	167,04	187,92	208,80
Water tank volume l	500	500	500	500	500	500	500	500	1000	1000	1000	1000

\* Units only available for the non-EU market

Performances are referred to the following conditions:

(1) Heating: Ambient temperature 7°C DB, 6°C WB, water temperature 30/35°C.

(2) Average conditions, low temperature, variable - Reg EU 811/2013

(3) Sound power level in accordance with ISO 3744.

(4) Sound pressure level at 10 mt from the unit in free field conditions in accordance with ISO 3744.

Heating only version (HH)

HA/LS/HH - P2S/P2U	242	292	412	432	492	602	702	802	902	1002	1202	1402
Heating capacity (EN14511) <sup>(1)</sup> kW	22,2	29,6	37,3	46,9	50,7	61,2	67,3	72,6	93,1	104,7	114,4	137,2
Total input power (EN14511) <sup>(1)</sup> kW	5,3	7,1	9,0	11,4	12,0	13,6	15,4	17,0	22,1	25,3	28,4	32,4
COP (EN14511) <sup>(1)</sup> W/W	4,11	4,12	4,13	4,11	4,22	4,49	4,38	4,27	4,21	4,14	4,03	4,24
Energy Class <sup>(2)</sup>	A+	A+	A+	A+	A+	A++	A++	A++	A+	A+	A+	A+
SCOP <sup>(2)</sup> kWh/kWh	3,40	3,69	3,53	3,57	3,67	3,97	3,91	3,87	3,70	3,67	3,69	3,70
η <sub>s,h</sub> <sup>(2)</sup> %	132,9	144,7	138,0	139,6	143,8	155,7	153,4	151,6	145,1	143,7	144,4	144,8
Sound power <sup>(3)</sup> dB (A)	75	75	75	75	76	76	77	78	82	83	85	86
Sound pressure <sup>(4)</sup> dB (A)	43	43	43	43	44	44	45	46	50	51	53	54
HE/LS/HH - P2S/P2U	252	302	412	432	492	602	702	802	902	1002	1202	1402
Heating capacity (EN14511) <sup>(1)</sup> kW	22,2	29,6	37,3	47,1	50,8	61,2	67,3	74,9	93,2	104,9	114,9	137,1
Total input power (EN14511) <sup>(1)</sup> kW	5,3	7,1	8,8	11,5	11,8	13,3	15,1	17,2	21,2	24,5	27,8	30,9
COP (EN14511) <sup>(1)</sup> W/W	4,11	4,16	4,23	4,11	4,32	4,61	4,46	4,36	4,40	4,29	4,13	4,44
Energy Class <sup>(2)</sup>	A++	A++	A++	A++	A++	A++	A++	A++	A++	A++	A++	A++
SCOP <sup>(2)</sup> kWh/kWh	3,83	3,86	3,85	3,85	3,92	4,13	4,04	3,97	3,87	3,85	3,83	3,85
η <sub>s,h</sub> <sup>(2)</sup> %	150,1	151,4	150,9	151,1	153,6	162,0	158,4	155,8	151,7	150,8	150,2	151,0
Sound power <sup>(3)</sup> dB (A)	73	74	74	75	76	76	77	78	82	83	85	86
Sound pressure <sup>(4)</sup> dB (A)	41	42	42	43	44	44	45	46	50	51	53	54
Power supply V/Ph/Hz	400/3+N/50			400/3/50								
Compressors / Circuits n° / n°	2 / 1	2 / 1	2 / 1	2 / 1	2 / 1	2 / 1	2 / 1	2 / 1	2 / 1	2 / 1	2 / 1	2 / 1
Fans n°	1	1	2	2	2	2	2	2	2	2	2	3
Refrigerant	R410A	R410A	R410A	R410A	R410A	R410A	R410A	R410A	R410A	R410A	R410A	R410A
Refrigerant charge kg	10,0	10,0	10,0	10,0	14,5	19,0	19,0	19,0	27,0	27,0	27,0	36,0
Global warming potential (GWP)	2088	2088	2088	2088	2088	2088	2088	2088	2088	2088	2088	2088
Equivalent CO <sub>2</sub> charge t	20,88	20,88	20,88	20,88	30,27	39,67	39,67	39,67	56,37	56,37	56,37	75,16
Water tank volume l	100	100	100	100	100	300	300	300	300	300	300	500

HA/LS/HH - P2S/P2U	1602	1802	2002	2302	2502	2504	3004	3204	3504	4004	4504	5004 *
Heating capacity (EN14511) <sup>(1)</sup> kW	150,8	167,2	182,0	209,7	239,2	228,6	270,2	295,6	335,0	363,1	398,6	458,7
Total input power (EN14511) <sup>(1)</sup> kW	35,8	41,3	45,4	50,3	55,8	56,7	67,0	74,1	83,5	90,3	103,5	116,4
COP (EN14511) <sup>(1)</sup> W/W	4,21	4,05	4,01	4,17	4,29	4,03	4,03	3,99	4,01	4,02	3,85	3,94
Energy Class <sup>(2)</sup>	A+	A+	A+	A+	A++	A+	A+	A+	A+	A+	A+	A+
SCOP <sup>(2)</sup> kWh/kWh	3,74	3,69	3,62	3,76	3,83	3,65	3,63	3,65	3,66	3,73	3,61	3,63
η <sub>s,h</sub> <sup>(2)</sup> %	146,4	144,7	141,9	147,3	150,3	143,1	142,0	142,9	143,3	146,1	141,4	142,0
Sound power <sup>(3)</sup> dB (A)	87	87	87	89	91	88	89	90	90	90	92	92
Sound pressure <sup>(4)</sup> dB (A)	55	55	55	57	59	56	57	58	58	58	60	60
HE/LS/HH - P2S/P2U	1602	1802	2002	2302	2502	2504	3004	3204	3504	4004	4504	5004 *
Heating capacity (EN14511) <sup>(1)</sup> kW	151,0	167,9	182,8	210,6	241,3	229,4	271,4	296,7	339,0	364,9	399,1	463,7
Total input power (EN14511) <sup>(1)</sup> kW	34,4	40,2	45,5	49,4	54,8	55,8	63,9	71,5	83,7	88,8	102,1	115,1
COP (EN14511) <sup>(1)</sup> W/W	4,39	4,18	4,02	4,26	4,40	4,11	4,25	4,15	4,05	4,11	3,91	4,03
Energy Class <sup>(2)</sup>	A++	A++	A++	A++	A++	A++	A++	A++	A++	A++	A++	A++
SCOP <sup>(2)</sup> kWh/kWh	3,86	3,85	3,84	3,92	3,97	3,83	3,85	3,83	3,91	3,89	3,87	3,86
η <sub>s,h</sub> <sup>(2)</sup> %	151,3	150,9	150,4	153,6	155,6	150,2	151,1	150,3	153,5	152,4	151,9	151,5
Sound power <sup>(3)</sup> dB (A)	87	87	87	89	91	88	89	90	90	90	92	92
Sound pressure <sup>(4)</sup> dB (A)	55	55	55	57	59	56	57	58	58	58	60	60
Power supply V/Ph/Hz	400/3/50											
Compressors / Circuits n° / n°	2 / 1	2 / 1	2 / 1	2 / 1	2 / 1	4 / 2	4 / 2	4 / 2	4 / 2	4 / 2	4 / 2	4 / 2
Fans n°	3	3	3	3	3	4	6	6	6	6	8	8
Refrigerant	R410A	R410A	R410A	R410A	R410A	R410A	R410A	R410A	R410A	R410A	R410A	R410A
Refrigerant charge kg	36,0	36,0	45,0	45,0	60,0	60,0	72,0	72,0	72,0	90,0	90,0	100,0
Global warming potential (GWP)	2088	2088	2088	2088	2088	2088	2088	2088	2088	2088	2088	2088
Equivalent CO <sub>2</sub> charge t	75,16	75,16	93,96	93,96	125,28	125,28	150,33	150,33	150,33	187,92	187,92	208,80
Water tank volume l	500	500	500	500	1000	1000	1000	1000	1000	1000	1000	1000

\* Units only available for the non-EU market

Performances are referred to the following conditions:

- (1) Heating: Ambient temperature 7°C DB, 6°C WB, water temperature 30/35°C.
- (2) Average conditions, low temperature, variable - Reg EU 811/2013

(3) Sound power level in accordance with ISO 3744.

(4) Sound pressure level at 10 mt from the unit in free field conditions in accordance with ISO 3744.

Reversible heating/cooling version (RV)

SA/LS/RV - P2S/P2U	242	292	402	432	492	592	702	802	902	1002	1202	1402	
Heating capacity (EN14511) <sup>(1)</sup> kW	22,0	28,7	34,5	47,2	50,9	56,8	64,9	73,2	80,2	97,0	105,7	122,3	
Total input power (EN14511) <sup>(1)</sup> kW	5,8	7,3	9,1	12,2	12,6	14,4	16,0	17,9	20,8	24,3	27,3	30,7	
COP (EN14511) <sup>(1)</sup> W/W	3,83	3,93	3,80	3,86	4,04	3,94	4,06	4,10	3,86	4,00	3,87	3,98	
Energy Class <sup>(2)</sup>	A+	A+	A+	A+	A+	A+	A+	A+	A+	A+	A+	A+	
SCOP <sup>(2)</sup> kWh/kWh	3,27	3,58	3,41	3,34	3,48	3,54	3,43	3,47	3,42	3,50	3,39	3,50	
η <sub>s,h</sub> <sup>(2)</sup> %	127,9	140,1	133,3	130,4	136,3	138,6	134,3	135,9	133,7	137,1	132,7	136,9	
Cooling capacity (EN14511) <sup>(3)</sup> kW	17,8	24,1	28,4	38,8	42,7	48,2	55,2	60,2	69,7	83,3	91,6	102,6	
Total input power (EN14511) <sup>(3)</sup> kW	7,1	9,8	11,7	15,0	16,4	19,8	21,9	24,5	29,3	32,7	37,7	42,6	
EER (EN14511) <sup>(3)</sup> W/W	2,52	2,45	2,42	2,58	2,61	2,43	2,52	2,46	2,38	2,55	2,43	2,41	
Sound power <sup>(4)</sup> dB (A)	75	75	75	75	77	77	77	78	79	82	83	85	
Sound pressure <sup>(5)</sup> dB (A)	43	43	43	43	45	45	45	46	47	50	51	53	
SE/LS/RV - P2S/P2U	242	292	402	432	492	592	702	802	902	1002	1202	1402	
Heating capacity (EN14511) <sup>(1)</sup> kW	21,9	28,6	34,2	47,1	51,1	57,1	64,9	73,1	81,0	97,0	105,6	122,7	
Total input power (EN14511) <sup>(1)</sup> kW	5,6	7,2	8,8	11,9	12,4	14,4	15,8	17,6	20,9	24,0	27,3	30,5	
COP (EN14511) <sup>(1)</sup> W/W	3,92	3,95	3,87	3,95	4,13	3,97	4,10	4,15	3,88	4,04	3,87	4,02	
Energy Class <sup>(2)</sup>	A+	A+	A+	A+	A+	A+	A+	A+	A+	A+	A+	A+	
SCOP <sup>(2)</sup> kWh/kWh	3,40	3,66	3,53	3,46	3,59	3,62	3,68	3,71	3,63	3,71	3,64	3,73	
η <sub>s,h</sub> <sup>(2)</sup> %	132,8	143,2	138,3	135,5	140,4	141,7	144,1	145,4	142,1	145,3	142,5	146,1	
Cooling capacity (EN14511) <sup>(3)</sup> kW	17,7	24,1	28,2	39,0	43,5	48,9	55,6	61,3	70,3	84,3	92,0	103,5	
Total input power (EN14511) <sup>(3)</sup> kW	7,0	9,8	11,8	14,9	16,0	19,5	21,8	24,0	28,9	32,3	37,4	42,2	
EER (EN14511) <sup>(3)</sup> W/W	2,52	2,47	2,40	2,61	2,72	2,51	2,55	2,55	2,43	2,61	2,46	2,45	
Sound power <sup>(4)</sup> dB (A)	74	74	75	75	77	77	77	78	79	82	83	85	
Sound pressure <sup>(5)</sup> dB (A)	42	42	43	43	45	45	45	46	47	50	51	53	
Power supply	V/Ph/Hz	400/3+N/50						400/3/50					
Compressors / Circuits	n° / n°	2 / 1	2 / 1	2 / 1	2 / 1	2 / 1	2 / 1	2 / 1	2 / 1	2 / 1	2 / 1	2 / 1	
Fans	n°	1	1	2	2	2	2	2	2	3	3	3	
Refrigerant		R410A	R410A	R410A	R410A	R410A	R410A	R410A	R410A	R410A	R410A	R410A	
Refrigerant charge	kg	10,0	10,0	10,0	10,0	14,5	14,5	14,5	14,5	21,0	21,0	27,0	
Global warming potential (GWP)		2088	2088	2088	2088	2088	2088	2088	2088	2088	2088	2088	
Equivalent CO <sub>2</sub> charge	t	20,88	20,88	20,88	20,88	30,27	30,27	30,27	30,27	43,84	43,84	56,37	
Water tank volume	l	100	100	100	100	100	100	300	300	500	500	500	

SA/LS/RV - P2S/P2U	1602	1802	2002	2302	2502	2504	3004	3204	3504	4004	4504	5004 *
Heating capacity (EN14511) <sup>(1)</sup> kW	136,0	157,3	169,0	196,6	215,0	211,8	226,1	258,8	330,6	357,4	393,3	431,7
Total input power (EN14511) <sup>(1)</sup> kW	34,6	40,3	43,4	51,5	60,4	58,2	64,8	71,9	85,2	93,8	103,0	116,4
COP (EN14511) <sup>(1)</sup> W/W	3,93	3,90	3,89	3,82	3,56	3,64	3,49	3,60	3,88	3,81	3,82	3,71
Energy Class <sup>(2)</sup>	A+	A+	A+	A+	A+	A+	A+	A+	A+	A+	A+	A+
SCOP <sup>(2)</sup> kWh/kWh	3,50	3,48	3,46	3,45	3,24	3,25	3,23	3,26	3,25	3,27	3,24	3,34
η <sub>s,h</sub> <sup>(2)</sup> %	137,0	136,1	135,5	134,8	126,5	127,1	126,1	127,2	127,0	127,8	126,4	130,4
Cooling capacity (EN14511) <sup>(3)</sup> kW	115,6	131,9	143,0	173,0	197,2	192,3	210,8	231,8	286,3	312,9	349,4	401,8
Total input power (EN14511) <sup>(3)</sup> kW	47,2	53,8	63,6	68,9	76,7	76,0	87,5	97,8	106,0	121,8	138,1	153,4
EER (EN14511) <sup>(3)</sup> W/W	2,45	2,45	2,25	2,51	2,57	2,53	2,41	2,37	2,70	2,57	2,53	2,62
Sound power <sup>(4)</sup> dB (A)	86	86	86	89	90	87	89	90	90	90	92	93
Sound pressure <sup>(5)</sup> dB (A)	54	54	54	57	58	55	57	58	58	58	60	61
SE/LS/RV - P2S/P2U	1602	1802	2002	2302	2502	2504	3004	3204	3504	4004	4504	5004 *
Heating capacity (EN14511) <sup>(1)</sup> kW	137,0	157,8	170,2	197,7	217,6	213,2	227,7	261,7	330,6	357,5	396,6	435,4
Total input power (EN14511) <sup>(1)</sup> kW	34,6	38,8	43,3	51,5	60,3	57,9	65,1	71,9	82,9	92,1	102,7	116,7
COP (EN14511) <sup>(1)</sup> W/W	3,96	4,07	3,93	3,84	3,61	3,68	3,50	3,64	3,99	3,88	3,86	3,73
Energy Class <sup>(2)</sup>	A+	A+	A+	A+	A+	A+	A+	A+	A+	A+	A+	A+
SCOP <sup>(2)</sup> kWh/kWh	3,68	3,77	3,72	3,74	3,63	3,54	3,49	3,46	3,52	3,57	3,63	3,58
η <sub>s,h</sub> <sup>(2)</sup> %	144,0	147,8	145,8	146,4	142,1	138,6	136,5	135,2	137,9	139,6	142,3	140,0
Cooling capacity (EN14511) <sup>(3)</sup> kW	116,4	132,9	147,1	175,3	200,4	195,8	212,1	233,3	289,3	321,1	357,3	408,0
Total input power (EN14511) <sup>(3)</sup> kW	46,9	53,4	61,0	67,9	75,6	74,4	86,9	96,8	104,8	118,1	135,9	150,0
EER (EN14511) <sup>(3)</sup> W/W	2,48	2,49	2,41	2,58	2,65	2,63	2,44	2,41	2,76	2,72	2,63	2,72
Sound power <sup>(4)</sup> dB (A)	86	86	86	89	90	87	89	90	90	90	92	93
Sound pressure <sup>(5)</sup> dB (A)	54	54	54	57	58	55	57	58	58	58	60	61
Power supply	V/Ph/Hz	400/3/50										
Compressors / Circuits	n° / n°	2 / 1	2 / 1	2 / 1	2 / 1	2 / 1	4 / 2	4 / 2	4 / 2	4 / 2	4 / 2	4 / 2
Fans	n°	4	4	4	3	4	4	4	4	6	6	8
Refrigerant		R410A	R410A	R410A	R410A	R410A	R410A	R410A	R410A	R410A	R410A	R410A
Refrigerant charge	kg	27,0	36,0	36,0	45,0	45,0	45,0	54,0	54,0	72,0	80,0	100,0
Global warming potential (GWP)		2088	2088	2088	2088	2088	2088	2088	2088	2088	2088	2088
Equivalent CO <sub>2</sub> charge	t	56,37	75,16	75,16	93,96	93,96	93,96	112,75	112,75	150,33	167,04	208,80
Water tank volume	l	500	500	500	500	500	500	500	1000	1000	1000	1000

\* Units only available for the non-EU market

Performances are referred to the following conditions:

- (1) Heating: Ambient temperature 7°C DB, 6°C WB, water temperature 30/35°C.
- (2) Average conditions, low temperature, variable - Reg EU 811/2013

(3) Cooling: ambient air temperature 35°C, evaporator water temperature in/out 12/7 °C.

(4) Sound power level in accordance with ISO 3744..

(5) Sound pressure level at 10 mt from the unit in free field conditions in accordance with ISO 3744.

Reversible heating/cooling version (RV)

LHT

HA/LS/RV - P2S/P2U	242	292	412	432	492	602	702	802	902	1002	1202	1402	
Heating capacity (EN14511) <sup>(1)</sup> kW	22,2	29,6	37,3	46,9	50,7	61,2	67,3	72,6	93,1	104,7	114,4	137,2	
Total input power (EN14511) <sup>(1)</sup> kW	5,3	7,1	9,0	11,4	12,0	13,6	15,4	17,0	22,1	25,3	28,4	32,4	
COP (EN14511) <sup>(1)</sup> W/W	4,11	4,12	4,13	4,11	4,22	4,49	4,38	4,27	4,21	4,14	4,03	4,24	
Energy Class <sup>(2)</sup>	A+	A+	A+	A+	A+	A++	A++	A++	A+	A+	A+	A+	
SCOP <sup>(2)</sup> kWh/kWh	3,40	3,69	3,53	3,57	3,67	3,97	3,91	3,87	3,70	3,67	3,69	3,70	
η <sub>s,h</sub> <sup>(2)</sup> %	132,9	144,7	138,0	139,6	143,8	155,7	153,4	151,6	145,1	143,7	144,4	144,8	
Cooling capacity (EN14511) <sup>(3)</sup> kW	18,1	24,5	30,8	39,9	44,2	52,3	57,4	62,6	79,8	89,6	97,8	117,0	
Total input power (EN14511) <sup>(3)</sup> kW	7,0	9,6	10,9	15,0	16,3	18,4	21,5	24,5	27,2	31,7	36,5	43,8	
EER (EN14511) <sup>(3)</sup> W/W	2,57	2,56	2,84	2,65	2,72	2,84	2,67	2,55	2,93	2,83	2,68	2,67	
Sound power <sup>(4)</sup> dB (A)	75	75	75	75	76	76	77	78	82	83	85	86	
Sound pressure <sup>(5)</sup> dB (A)	43	43	43	43	44	44	45	46	50	51	53	54	
<b>HE/LS/RV - P2S/P2U</b>	<b>242</b>	<b>292</b>	<b>412</b>	<b>432</b>	<b>492</b>	<b>602</b>	<b>702</b>	<b>802</b>	<b>902</b>	<b>1002</b>	<b>1202</b>	<b>1402</b>	
Heating capacity (EN14511) <sup>(1)</sup> kW	22,2	29,6	37,3	47,1	50,8	61,2	67,3	74,9	93,2	104,9	114,9	137,1	
Total input power (EN14511) <sup>(1)</sup> kW	5,3	7,1	8,8	11,5	11,8	13,3	15,1	17,2	21,2	24,5	27,8	30,9	
COP (EN14511) <sup>(1)</sup> W/W	4,11	4,16	4,23	4,11	4,32	4,61	4,46	4,36	4,40	4,29	4,13	4,44	
Energy Class <sup>(2)</sup>	A++	A++	A++	A++	A++	A++	A++	A++	A++	A++	A++	A++	
SCOP <sup>(2)</sup> kWh/kWh	3,83	3,86	3,85	3,85	3,92	4,13	4,04	3,97	3,87	3,85	3,83	3,85	
η <sub>s,h</sub> <sup>(2)</sup> %	150,1	151,4	150,9	151,1	153,6	162,0	158,4	155,8	151,7	150,8	150,2	151,0	
Cooling capacity (EN14511) <sup>(3)</sup> kW	18,1	25,4	30,5	40,6	44,2	52,4	57,5	65,4	80,5	90,2	100,5	117,4	
Total input power (EN14511) <sup>(3)</sup> kW	6,9	8,4	11,0	14,5	16,1	18,3	21,3	22,8	26,6	31,2	35,1	38,6	
EER (EN14511) <sup>(3)</sup> W/W	2,62	3,02	2,78	2,81	2,74	2,87	2,70	2,87	3,03	2,89	2,86	3,04	
Sound power <sup>(4)</sup> dB (A)	73	74	74	75	76	76	77	78	82	83	85	86	
Sound pressure <sup>(5)</sup> dB (A)	41	42	42	43	44	44	45	46	50	51	53	54	
Power supply	V/Ph/Hz	400/3+N/50						400/3/50					
Compressors / Circuits	n° / n°	2 / 1	2 / 1	2 / 1	2 / 1	2 / 1	2 / 1	2 / 1	2 / 1	2 / 1	2 / 1	2 / 1	
Fans	n°	1	1	2	2	2	2	2	2	2	2	3	
Refrigerant		R410A	R410A	R410A	R410A	R410A	R410A	R410A	R410A	R410A	R410A	R410A	
Refrigerant charge	kg	10,0	10,0	10,0	10,0	14,5	19,0	19,0	19,0	27,0	27,0	36,0	
Global warming potential (GWP)		2088	2088	2088	2088	2088	2088	2088	2088	2088	2088	2088	
Equivalent CO <sub>2</sub> charge	t	20,88	20,88	20,88	20,88	30,27	39,67	39,67	39,67	56,37	56,37	75,16	
Water tank volume	l	100	100	100	100	100	300	300	300	300	300	500	

HA/LS/RV - P2S/P2U	1602	1802	2002	2302	2502	2504	3004	3204	3504	4004	4504	5004 *	
Heating capacity (EN14511) <sup>(1)</sup> kW	150,8	167,2	182,0	209,7	239,2	228,6	270,2	295,6	335,0	363,1	398,6	458,7	
Total input power (EN14511) <sup>(1)</sup> kW	35,8	41,3	45,4	50,3	55,8	56,7	67,0	74,1	83,5	90,3	103,5	116,4	
COP (EN14511) <sup>(1)</sup> W/W	4,21	4,05	4,01	4,17	4,29	4,03	4,03	3,99	4,01	4,02	3,85	3,94	
Energy Class <sup>(2)</sup>	A+	A+	A+	A+	A++	A+	A+	A+	A+	A+	A+	A+	
SCOP <sup>(2)</sup> kWh/kWh	3,74	3,69	3,62	3,76	3,83	3,65	3,63	3,65	3,66	3,73	3,61	3,63	
η <sub>s,h</sub> <sup>(2)</sup> %	146,4	144,7	141,9	147,3	150,3	143,1	142,0	142,9	143,3	146,1	141,4	142,0	
Cooling capacity (EN14511) <sup>(3)</sup> kW	129,5	144,5	159,3	180,2	199,7	197,4	230,1	257,2	288,2	325,6	366,0	405,0	
Total input power (EN14511) <sup>(3)</sup> kW	44,3	51,8	58,8	66,3	74,5	73,1	81,9	91,5	105,6	116,7	136,1	155,2	
EER (EN14511) <sup>(3)</sup> W/W	2,92	2,79	2,71	2,72	2,68	2,70	2,81	2,81	2,73	2,79	2,69	2,61	
Sound power <sup>(4)</sup> dB (A)	87	87	87	89	91	88	89	90	90	90	92	92	
Sound pressure <sup>(5)</sup> dB (A)	55	55	55	57	59	56	57	58	58	58	60	60	
<b>HE/LS/RV - P2S/P2U</b>	<b>1602</b>	<b>1802</b>	<b>2002</b>	<b>2302</b>	<b>2502</b>	<b>2504</b>	<b>3004</b>	<b>3204</b>	<b>3504</b>	<b>4004</b>	<b>4504</b>	<b>5004 *</b>	
Heating capacity (EN14511) <sup>(1)</sup> kW	151,0	167,9	182,8	210,6	241,3	229,4	271,4	296,7	339,0	364,9	399,1	463,7	
Total input power (EN14511) <sup>(1)</sup> kW	34,4	40,2	45,5	49,4	54,8	55,8	63,9	71,5	83,7	88,8	102,1	115,1	
COP (EN14511) <sup>(1)</sup> W/W	4,39	4,18	4,02	4,26	4,40	4,11	4,25	4,15	4,05	4,11	3,91	4,03	
Energy Class <sup>(2)</sup>	A++	A++	A++	A++	A++	A++	A++	A++	A++	A++	A++	A++	
SCOP <sup>(2)</sup> kWh/kWh	3,86	3,85	3,84	3,92	3,97	3,83	3,85	3,83	3,91	3,89	3,87	3,86	
η <sub>s,h</sub> <sup>(2)</sup> %	151,3	150,9	150,4	153,6	155,6	150,2	151,1	150,3	153,5	152,4	151,9	151,5	
Cooling capacity (EN14511) <sup>(3)</sup> kW	129,5	146,8	159,2	180,4	202,1	198,5	231,0	259,7	289,4	322,6	368,5	416,0	
Total input power (EN14511) <sup>(3)</sup> kW	44,0	50,8	58,7	66,1	73,2	72,7	80,5	89,2	105,2	118,2	135,0	154,6	
EER (EN14511) <sup>(3)</sup> W/W	2,94	2,89	2,71	2,73	2,76	2,73	2,87	2,91	2,75	2,73	2,73	2,69	
Sound power <sup>(4)</sup> dB (A)	87	87	87	89	91	88	89	90	90	90	92	92	
Sound pressure <sup>(5)</sup> dB (A)	55	55	55	57	59	56	57	58	58	58	60	60	
Power supply	V/Ph/Hz	400/3/50						400/3/50					
Compressors / Circuits	n° / n°	2 / 1	2 / 1	2 / 1	2 / 1	2 / 1	4 / 2	4 / 2	4 / 2	4 / 2	4 / 2	4 / 2	
Fans	n°	3	3	3	3	3	4	6	6	6	8	8	
Refrigerant		R410A	R410A	R410A	R410A	R410A	R410A	R410A	R410A	R410A	R410A	R410A	
Refrigerant charge	kg	36,0	36,0	45,0	45,0	60,0	60,0	72,0	72,0	90,0	90,0	100,0	
Global warming potential (GWP)		2088	2088	2088	2088	2088	2088	2088	2088	2088	2088	2088	
Equivalent CO <sub>2</sub> charge	t	75,16	75,16	93,96	93,96	125,28	125,28	150,33	150,33	150,33	187,92	187,92	
Water tank volume	l	500	500	500	500	1000	1000	1000	1000	1000	1000	1000	

\* Units only available for the non-EU market

Performances are referred to the following conditions:

- (1) Heating: Ambient temperature 7°C DB, 6°C WB, water temperature 30/35°C.
- (2) Average conditions, low temperature, variable - Reg EU 811/2013

(3) Cooling: ambient air temperature 35°C, evaporator water temperature in/out 12/7 °C.

(4) Sound power level in accordance with ISO 3744..

(5) Sound pressure level at 10 mt from the unit in free field conditions in accordance with ISO 3744.

Reversible heating/cooling version (RV)

HA/XL/RV - P2S/P2U	252	302	412	432	492	602	702	802	902	1002	1202	1402
Heating capacity (EN14511) <sup>(1)</sup> kW	23,1	29,8	36,8	46,2	49,4	60,1	65,9	71,0	91,6	101,7	111,1	134,8
Total input power (EN14511) <sup>(1)</sup> kW	5,6	7,2	8,8	11,2	11,7	13,4	15,1	16,7	20,9	23,9	27,0	30,5
COP (EN14511) <sup>(1)</sup> W/W	4,12	4,13	4,20	4,12	4,21	4,50	4,35	4,25	4,39	4,26	4,11	4,42
Energy Class <sup>(2)</sup>	A+	A+	A+	A+	A+	A++	A++	A++	A++	A++	A+	A++
SCOP <sup>(2)</sup> kWh/kWh	3,36	3,58	3,68	3,65	3,77	4,04	3,96	3,89	3,88	3,87	3,72	3,95
η <sub>s,h</sub> <sup>(2)</sup> %	131,2	140,2	144,0	143,0	147,9	158,6	155,4	152,7	152,2	151,6	145,7	155,1
Cooling capacity (EN14511) <sup>(3)</sup> kW	19,5	24,7	29,7	38,9	42,8	50,4	55,7	60,3	78,1	86,4	94,1	114,3
Total input power (EN14511) <sup>(3)</sup> kW	7,2	9,7	11,2	15,4	16,7	19,1	22,0	25,1	26,7	31,5	36,8	39,0
EER (EN14511) <sup>(3)</sup> W/W	2,72	2,55	2,65	2,54	2,57	2,64	2,53	2,40	2,93	2,74	2,56	2,93
Sound power <sup>(4)</sup> dB (A)	70	70	70	70	72	72	72	73	75	76	78	80
Sound pressure <sup>(5)</sup> dB (A)	38	38	38	38	40	40	40	41	43	44	46	48
<b>HE/XL/RV - P2S/P2U</b>	<b>252</b>	<b>302</b>	<b>412</b>	<b>432</b>	<b>492</b>	<b>602</b>	<b>702</b>	<b>802</b>	<b>902</b>	<b>1002</b>	<b>1202</b>	<b>1402</b>
Heating capacity (EN14511) <sup>(1)</sup> kW	23,1	29,8	36,9	46,3	49,7	60,0	65,9	71,0	91,4	101,4	111,0	134,5
Total input power (EN14511) <sup>(1)</sup> kW	5,5	7,1	8,5	11,1	11,4	13,1	14,9	16,6	20,3	23,4	26,4	29,6
COP (EN14511) <sup>(1)</sup> W/W	4,23	4,18	4,34	4,16	4,35	4,59	4,42	4,29	4,51	4,34	4,21	4,55
Energy Class <sup>(2)</sup>	A++	A++	A++	A++	A++	A++	A++	A++	A++	A++	A++	A++
SCOP <sup>(2)</sup> kWh/kWh	3,83	3,86	3,92	3,91	3,98	4,19	4,09	4,00	4,05	4,01	3,86	4,13
η <sub>s,h</sub> <sup>(2)</sup> %	150,2	151,3	153,8	153,2	156,2	164,5	160,6	156,9	158,8	157,4	151,5	162,3
Cooling capacity (EN14511) <sup>(3)</sup> kW	19,7	25,4	30,4	39,9	44,1	52,4	57,5	63,4	80,5	90,2	100,5	117,4
Total input power (EN14511) <sup>(3)</sup> kW	7,0	9,3	10,9	14,9	16,2	18,3	21,3	24,0	26,6	31,2	35,2	38,6
EER (EN14511) <sup>(3)</sup> W/W	2,83	2,73	2,78	2,67	2,72	2,87	2,70	2,65	3,03	2,89	2,86	3,04
Sound power <sup>(4)</sup> dB (A)	68	68	68	69	72	72	72	73	74	76	78	79
Sound pressure <sup>(5)</sup> dB (A)	36	36	36	37	40	40	40	41	42	44	46	47
Power supply V/Ph/Hz	400/3+N/50			400/3/50								
Compressors / Circuits	n° / n°	2 / 1	2 / 1	2 / 1	2 / 1	2 / 1	2 / 1	2 / 1	2 / 1	2 / 1	2 / 1	2 / 1
Fans	n°	2	2	2	2	2	2	2	2	2	2	3
Refrigerant		R410A	R410A	R410A	R410A	R410A	R410A	R410A	R410A	R410A	R410A	R410A
Refrigerant charge	kg	10,0	10,0	10,0	10,0	14,5	19,0	19,0	19,0	27,0	27,0	36,0
Global warming potential (GWP)		2088	2088	2088	2088	2088	2088	2088	2088	2088	2088	2088
Equivalent CO <sub>2</sub> charge	t	20,88	20,88	20,88	20,88	30,27	39,67	39,67	39,67	56,37	56,37	75,16
Water tank volume	l	100	100	100	100	100	300	300	300	300	300	500

HA/XL/RV - P2S/P2U	1602	1802	2002	2302	2502	2504	3004	3204	3504	4004	4504	5004 *
Heating capacity (EN14511) <sup>(1)</sup> kW	148,2	162,5	176,9	204,1	232,2	221,2	265,0	287,3	317,0	349,0	389,3	439,8
Total input power (EN14511) <sup>(1)</sup> kW	33,8	39,3	43,9	48,1	53,8	54,0	62,6	69,7	78,3	85,5	97,8	109,1
COP (EN14511) <sup>(1)</sup> W/W	4,39	4,13	4,03	4,24	4,32	4,10	4,23	4,12	4,05	4,08	3,98	4,03
Energy Class <sup>(2)</sup>	A++	A++	A+	A++	A++	A+	A+	A+	A+	A++	A++	A+
SCOP <sup>(2)</sup> kWh/kWh	3,92	3,86	3,76	4,00	3,98	3,74	3,79	3,78	3,82	3,88	3,83	3,81
η <sub>s,h</sub> <sup>(2)</sup> %	153,7	151,3	147,3	156,8	156,3	146,5	148,6	148,2	149,8	152,0	150,3	149,2
Cooling capacity (EN14511) <sup>(3)</sup> kW	124,4	139,3	152,2	174,1	187,4	190,3	223,6	245,3	275,7	306,0	353,1	381,9
Total input power (EN14511) <sup>(3)</sup> kW	44,4	52,0	59,7	67,0	78,1	73,8	80,1	91,5	106,4	120,5	135,8	155,9
EER (EN14511) <sup>(3)</sup> W/W	2,80	2,68	2,55	2,60	2,40	2,58	2,79	2,68	2,59	2,54	2,60	2,45
Sound power <sup>(4)</sup> dB (A)	81	81	81	83	84	81	83	84	84	84	86	87
Sound pressure <sup>(5)</sup> dB (A)	49	49	49	51	52	49	51	52	52	52	54	55
<b>HE/XL/RV - P2S/P2U</b>	<b>1602</b>	<b>1802</b>	<b>2002</b>	<b>2302</b>	<b>2502</b>	<b>2504</b>	<b>3004</b>	<b>3204</b>	<b>3504</b>	<b>4004</b>	<b>4504</b>	<b>5004 *</b>
Heating capacity (EN14511) <sup>(1)</sup> kW	147,7	162,2	175,5	202,8	230,8	220,5	264,9	287,2	317,0	348,5	396,4	441,7
Total input power (EN14511) <sup>(1)</sup> kW	33,0	38,6	43,4	47,6	52,9	53,0	60,9	68,2	77,1	84,6	95,7	108,0
COP (EN14511) <sup>(1)</sup> W/W	4,48	4,20	4,04	4,26	4,36	4,16	4,35	4,21	4,11	4,12	4,14	4,09
Energy Class <sup>(2)</sup>	A++	A++	A++	A++	A++	A++	A++	A++	A++	A++	A++	A++
SCOP <sup>(2)</sup> kWh/kWh	4,06	4,01	3,85	4,10	4,06	3,84	3,97	3,92	3,96	3,97	3,97	3,91
η <sub>s,h</sub> <sup>(2)</sup> %	159,5	157,4	151,1	161,0	159,3	150,4	155,9	153,8	155,5	155,9	155,8	153,5
Cooling capacity (EN14511) <sup>(3)</sup> kW	129,5	146,8	159,2	180,4	202,1	198,5	231,0	259,7	289,4	322,6	368,5	406,9
Total input power (EN14511) <sup>(3)</sup> kW	44,1	50,8	58,8	66,2	73,3	72,7	80,5	89,2	105,2	118,2	135,0	151,3
EER (EN14511) <sup>(3)</sup> W/W	2,94	2,89	2,71	2,73	2,76	2,73	2,87	2,91	2,75	2,73	2,73	2,69
Sound power <sup>(4)</sup> dB (A)	80	81	81	83	84	81	82	83	84	84	86	87
Sound pressure <sup>(5)</sup> dB (A)	48	49	49	51	52	49	50	51	52	52	54	55
Power supply V/Ph/Hz	400/3/50											
Compressors / Circuits	n° / n°	2 / 1	2 / 1	2 / 1	2 / 1	4 / 2	4 / 2	4 / 2	4 / 2	4 / 2	4 / 2	4 / 2
Fans	n°	3	3	3	3	4	6	6	6	6	8	8
Refrigerant		R410A	R410A	R410A	R410A	R410A	R410A	R410A	R410A	R410A	R410A	R410A
Refrigerant charge	kg	36,0	36,0	45,0	45,0	60,0	60,0	72,0	72,0	72,0	90,0	100,0
Global warming potential (GWP)		2088	2088	2088	2088	2088	2088	2088	2088	2088	2088	2088
Equivalent CO <sub>2</sub> charge	t	75,16	75,16	93,96	93,96	125,28	125,28	150,33	150,33	150,33	187,92	208,80
Water tank volume	l	500	500	500	500	500	1000	1000	1000	1000	1000	1000

\* Units only available for the non-EU market

Performances are referred to the following conditions:

(1) Heating: Ambient temperature 7°C DB, 6°C WB, water temperature 30/35°C.

(2) Average conditions, low temperature, variable - Reg EU 811/2013

(3) Cooling: ambient air temperature 35°C, evaporator water temperature in/out 12/7 °C.

(4) Sound power level in accordance with ISO 3744..

(5) Sound pressure level at 10 mt from the unit in free field conditions in accordance with ISO 3744.

## COMPONENTS

### FRAME

All units are made from hot-galvanised sheet steel, painted with polyurethane powder enamel and stoved at 180°C to provide maximum protection against corrosion. The frame is self-supporting with removable panels. All screws and rivets used are made from stainless steel. The standard colour of the units is RAL9018.

### REFRIGERANT CIRCUIT

The refrigerant utilised is R410A. The refrigerant circuit is assembled using internationally recognised brand name components with all brazing and welding being performed in accordance with ISO 97/23. The refrigerant circuit includes: sight glass, filter drier, two thermal expansion valves (one for cooling mode, one for heating mode) with external equalizer, 4 way reversing valve, check valves, liquid receiver, Schrader valves for maintenance and control, pressure safety device (for compliance with PED regulations).

### COMPRESSORS

The compressors used are a high performance scroll type that incorporates a special scroll design which enhances the efficiency of the refrigerant cycle when the source temperature is low. In all units the compressors are connected in tandem. The compressors are all supplied with a crankcase heater and thermal overload protection by a klixon embedded in the motor winding. They are mounted in a separate enclosure in order to be separated from the air stream thus enabling them to be maintained even if the unit is operating. Access to this enclosure is by the front panel of the unit. The crankcase heater is always powered when the compressor is in stand-by.

### SOURCE HEAT EXCHANGER

The source heat exchanger is made from copper pipes and aluminium fins. Dimensioning of the copper pipes and the aluminium fins is optimized in order to obtain excellent performance. The tubes are mechanically expanded into the fins in order to maximise heat transfer. Furthermore, the design guarantees a low air side pressure drop thus enabling the use of low rotation speed (and hence low noise) fans. All heat exchangers are supplied standard with fins hydrophilic coating.

### USER HEAT EXCHANGERS

The user heat exchanger is a braze welded, plate type heat exchanger, manufactured from AISI 316 stainless steel. The use of this type of exchanger results in a massive reduction of the refrigerant charge of the unit compared to a traditional shell-in-tube type. A further advantage is a reduction in the overall dimensions of the unit. The exchangers are factory insulated with flexible close cell material and can be fitted with an antifreeze heater (accessory). Each exchanger is fitted with a temperature sensor on the discharge water side for antifreeze protection.

### FANS

The fans are direct drive axial type with aluminium aerofoil blades, are statically and dynamically balanced and are supplied complete with a safety fan guard complying with the requirements of EN 60335. They are fixed to the unit frame via rubber anti-vibration mountings. The electric motors, in LS versions are 6 poles type rotating at approximately 900 rpm. In the XL versions the fans are 8 poles type (approx 600 rpm). The motors are fitted with integrated thermal overload protection and have a moisture protection rating of IP 54.

### MICROPROCESSORS

All units are supplied as standard complete with control panel. The microprocessor controls the following functions: control of the water temperature, antifreeze protection, compressor timing, compressor automatic starting sequence (For multiple compressors), alarm reset. The control panel is supplied with display showing all operational icons. The microprocessor is

set for automatic defrost (when operating in severe ambient conditions) and for summer/ winter change over (only for RV versions). The control also manages the anti-legionella program, the integration with other heating sources (electric heaters, boilers, solar panels etc), the operation of a three port modulating valve (for diverting to DHW or heating) and both the heating circuit pump and the domestic hot water circuit pump. If required (available as an option), the microprocessor can be configured in order for it to connect to a site BMS system thus enabling remote control and management.

### ELECTRIC ENCLOSURE

The enclosure is manufactured in order to comply with the requirements of the electromagnetic compatibility standards CEE EN60204. Access to the enclosure is achieved by removing the front panel of the unit. The following components are supplied as standard on all units: main switch, a sequence relay that disables the power supply in the event that the phase sequence is incorrect (scroll compressors can be damaged if they rotate in the wrong direction), thermal overloads (protection of pumps and fans), compressor fuses, control circuit automatic breakers, compressor contactors, fan contactors and pump contactors. The terminal board has volt free contacts for remote ON-OFF, Summer/ winter change over (heat pumps only) and general alarm.

### CONTROL AND PROTECTION DEVICES

All units are supplied with the following controls and protections: user water return temperature sensor, antifreeze protection temperature sensor installed on users water output, domestic hot water supply and return temperature sensors (only versions P2S), high pressure manual reset, low pressure automatic reset, compressor thermal protection, air fan, thermal protection, pressure transducer (used to optimize the defrost cycle and to adjust the fan speed depending on ambient conditions), flow switch. All units in HA and HE versions are also fitted with a temperature probe sensor with "Energy Saving" function, supplied in a separate plastic box, which can be used to stop the pump use during periods of stand-by, when the water temperature reaches the set point. Doing this the power consumption of the unit is strongly reduced. The probe sensor must be positioned in the hydraulic compensator present at the screening technique. The domestic hot water circuit (only versions P2S) is already equipped with this probe, but it must be installed in the user circuit.

## VERSIONS

### HA/XL HE/XL Super low noise version

All HA and HE units in XL super low noise version are supplied, as standard, with the latest 'Floating Frame' technology that completely isolates the compressors from the main casing, thereby eliminating vibration and noise from this source. The 'Floating Frame' is a special vibration and acoustic damping system that consists of a base plate and acoustic enclosure that houses the compressors. The base plate is separated from the supporting frame of the unit by soft steel springs that have a high damping power. Within the enclosure, the compressors are mounted on rubber shock absorbers on the floating base plate. The enclosure is manufactured from galvanized steel sandwich panels that have a micro-perforated inner skin and a core of 30 mm thick, high density (25 kg/m<sup>3</sup>). The entire arrangement provides a double damping system and acoustic attenuation. The compressor refrigerant pipes are connected to the refrigerant circuit through "anaconda" flexible connections. Flexible connections are also used on the water pipework within the unit. The combination of these systems results in an overall noise reduction in the region of 6-8 dB(A).

**VERSION HH**

HH heating only versions are available in the P2U and P2S configuration only.

**Version RV**

This version uses 2 hydraulic connections and is able to produce hot water in winter and cold water in summer. The unit is combined with a 2-pipe system.

**SA Version**

Standard efficiency version, according to current standard. Unit equipped with AC fans.

**SE Version**

Standard efficiency version, according to current standard. Unit equipped with EC fans.

**HA Version**

High efficiency version, according to current standard. Unit equipped with AC fans.

**HE Version**

High efficiency version, according to current standard. Unit equipped with EC fans.

**Version LS**

This version includes the complete acoustic insulation of the unit with compressor jackets and insulating material made with high density media and the interposition of heavy bitumen layer.

**P2U Version**

This is a two pipe version that can produce hot water for heating (HH heating only) and hot or cold water in the RV version. The RV is used with two pipe water based change-over systems. It is not able to produce domestic hot water.

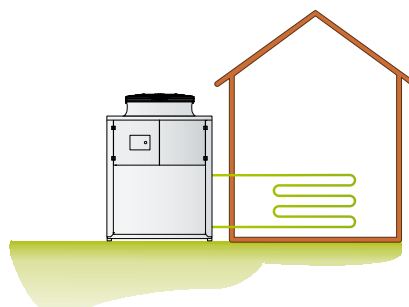

**P2S Version**

This is a two pipe version that can, in addition to producing hot water for heating (HH version) and hot and cold water in the RV version can also generate domestic hot water. The controller has dual heating set points (heating and DHW) and can also control a three port diverting valve that directs the DHW to the cylinder. DHW production has priority irrespective of the mode of operation of the unit. The unit is normally used with two pipe water based change-over systems.

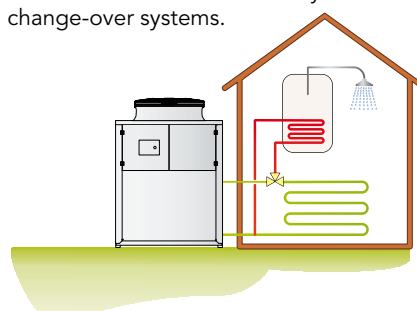

**OPERATION LIMITS**

(SA/SE versions)

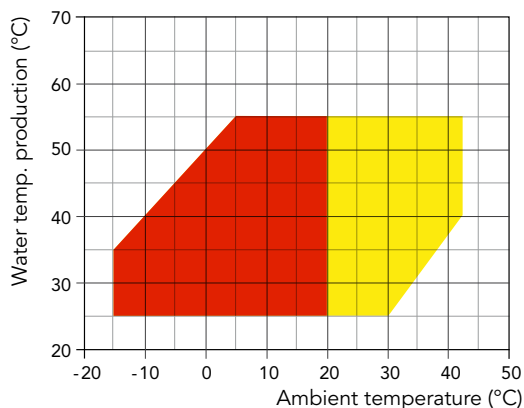

(HA/HE versions)

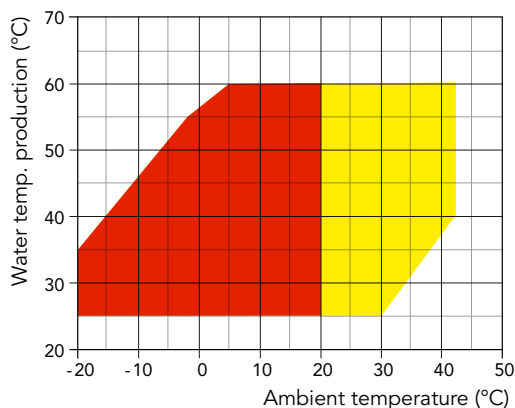

(RV versions Only)

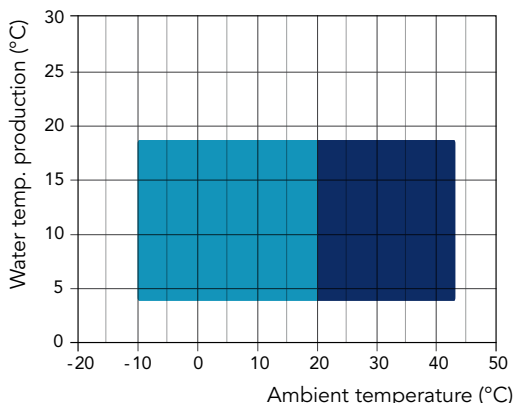

- Heating mode
- Heating mode with head pressure control (DCCF)
- Cooling with head pressure control (DCCF)
- Cooling mode

LHA SA-SE/HH-RV	LHA HA-HE /HH-RV	P2S/P2U	242 252	292 302	402	412	432	492	592	602	702	802	902	1002	1202
Flow switch			●	●	●	●	●	●	●	●	●	●	●	●	●
"Floating frame" Technology - LS Version			-	-	-	-	-	-	-	-	-	-	-	-	-
"Floating frame" Technology - XL Version			●	●	●	●	●	●	●	●	●	●	●	●	●
E.C. fans - SA versions	VECE		-	-	-	-	-	-	-	-	-	-	-	-	-
E.C. fans - SE versions	VECE		●	●	●	●	●	●	●	●	●	●	●	●	●
E.C. fans - HA versions	VECE		-	-	-	-	-	-	-	-	-	-	-	-	-
E.C. fans - HE versions	VECE		●	●	●	●	●	●	●	●	●	●	●	●	●
Condensate discharge drip tray with antifreeze heater	BRCA		○	○	○	○	○	○	○	○	○	○	○	○	○
Fans regulation by phase cut	DCCF		X	X	X	X	X	X	X	X	X	X	X	X	X
Antifreeze kit for 2 pipe units	RAEV2		○	○	○	○	○	○	○	○	○	○	○	○	○
Electronic soft starter	DSSE		○	○	○	○	○	○	○	○	○	○	○	○	○
Serial interface card RS485	INSE		●	●	●	●	●	●	●	●	●	●	●	●	●
Rubber anti-vibration mountings	KAVG		○	○	○	○	○	○	○	○	○	○	○	○	○
Remote control panel	PCRL		○	○	○	○	○	○	○	○	○	○	○	○	○
Electronic expansion valve	VTEE		○	○	○	○	○	○	○	○	○	○	○	○	○
Cascade control system via RS485	SGRS		○	○	○	○	○	○	○	○	○	○	○	○	○
Hydraulic kit with one pump with tank	A1ZZU		○	○	○	○	○	○	○	○	○	○	○	○	○
Hydraulic kit with two pumps with tank	A2ZZU		○	○	○	○	○	○	○	○	○	○	○	○	○
Hydraulic kit with one pump without tank	A1NTU		○	○	○	○	○	○	○	○	○	○	○	○	○
Hydraulic kit with two pumps without tank	A2NTU		○	○	○	○	○	○	○	○	○	○	○	○	○

X Necessary for P2S version    ● Standard ○ Optional - Not available  
Optional for P2U version

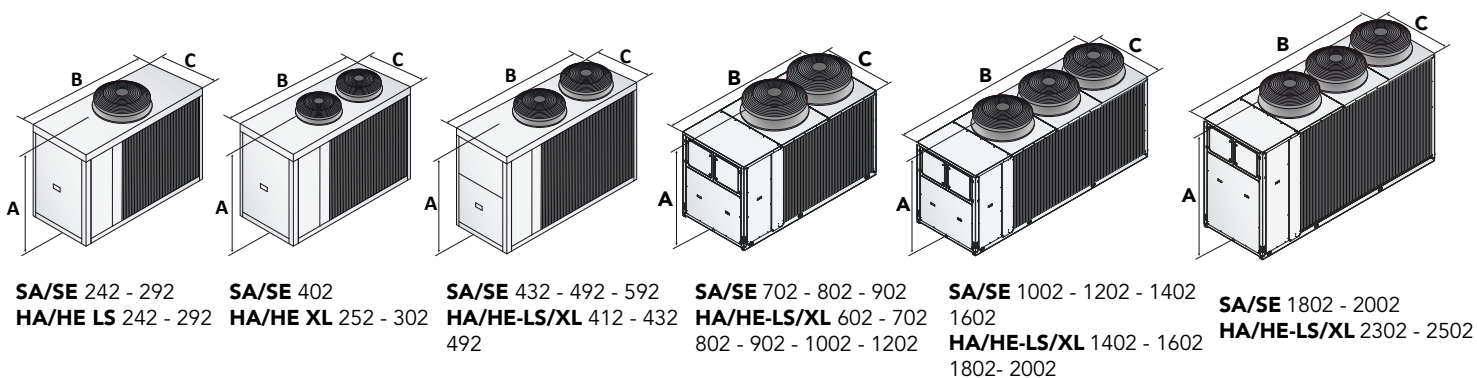

		242/252	292/302	402	412	432	492	592	602	702	802	902	1002	1202
A (mm)	SA-SE/LS	1500	1500	1500	--	1690	1690	1690	--	1880	1880	1880	1880	1880
B (mm)	SA-SE/LS	1915	1915	1915	--	2400	2400	2400	--	2905	2905	2905	3905	3905
C (mm)	SA-SE/LS	875	875	875	--	1150	1150	1150	--	1150	1150	1150	1150	1150
kg	SA-SE/LS	550	550	560	--	670	700	760	--	880	890	910	1190	1270
A (mm)	HA-HE/LS	1500	1500	--	1690	1690	1690	--	1880	1880	1880	1880	1880	1880
B (mm)	HA-HE/LS	1915	1915	--	2400	2400	2400	--	2905	2905	2905	2905	2905	2905
C (mm)	HA-HE/LS	875	875	--	1150	1150	1150	--	1150	1150	1150	1150	1150	1150
kg	HA-HE/LS	560	560	--	670	690	720	--	1060	1060	1070	1120	1160	1240
A (mm)	HA-HE/XL	1500	1500	--	1690	1690	1690	--	1880	1880	1880	1880	1880	1880
B (mm)	HA-HE/XL	1915	1915	--	2400	2400	2400	--	2905	2905	2905	2905	2905	2905
C (mm)	HA-HE/XL	875	875	--	1150	1150	1150	--	1150	1150	1150	1150	1150	1150
kg	HA-HE/XL	570	570	--	680	710	740	--	1080	1080	1090	1140	1180	1260

LHA SA-SE/HH-RV	LHA HA-HE /HH-RV	P2S/P2U	1402	1602	1802	2002	2302	2502	2504	3004	3204	3504	4004	4504	5004
Flow switch			●	●	●	●	●	●	●	●	●	●	●	●	●
"Floating frame" Technology - LS Version			-	-	-	-	-	-	-	-	-	-	-	-	-
"Floating frame" Technology - XL Version			●	●	●	●	●	●	●	●	●	●	●	●	●
E.C. fans - SA versions	<b>VECE</b>		-	-	-	-	-	-	-	-	-	-	-	-	-
E.C. fans - SE versions	<b>VECE</b>		●	●	●	●	●	●	●	●	●	●	●	●	●
E.C. fans - HA versions	<b>VECE</b>		-	-	-	-	-	-	-	-	-	-	-	-	-
E.C. fans - HE versions	<b>VECE</b>		●	●	●	●	●	●	●	●	●	●	●	●	●
Condensate discharge drip tray with antifreeze heater	<b>BRCA</b>		○	○	○	○	○	○	○	○	○	○	○	○	○
Fans regulation by phase cut	<b>DCCF</b>		X	X	X	X	X	X	X	X	X	X	X	X	X
Antifreeze kit for 2 pipe units	<b>RAEV2</b>		○	○	○	○	○	○	○	○	○	○	○	○	○
Electronic soft starter	<b>DSSE</b>		○	○	○	○	○	○	○	○	○	○	○	○	○
Serial interface card RS485	<b>INSE</b>		●	●	●	●	●	●	●	●	●	●	●	●	●
Rubber anti-vibration mountings	<b>KAVG</b>		○	○	○	○	○	○	○	○	○	○	○	○	○
Remote control panel	<b>PCRL</b>		○	○	○	○	○	○	○	○	○	○	○	○	○
Electronic expansion valve	<b>VTEE</b>		○	○	○	○	○	○	○	○	○	○	○	○	○
Cascade control system via RS485	<b>SGRS</b>		○	○	○	○	○	○	○	○	○	○	○	○	○
Hydraulic kit with one pump with tank	<b>A1ZZU</b>		○	○	○	○	○	○	○	○	○	○	○	○	○
Hydraulic kit with two pumps with tank	<b>A2ZZU</b>		○	○	○	○	○	○	○	○	○	○	○	○	○
Hydraulic kit with one pump without tank	<b>A1NTU</b>		○	○	○	○	○	○	○	○	○	○	○	○	○
Hydraulic kit with two pumps without tank	<b>A2NTU</b>		○	○	○	○	○	○	○	○	○	○	○	○	○

X Necessary for P2S version ● Standard ○ Optional - Not available  
 Optional for P2U version

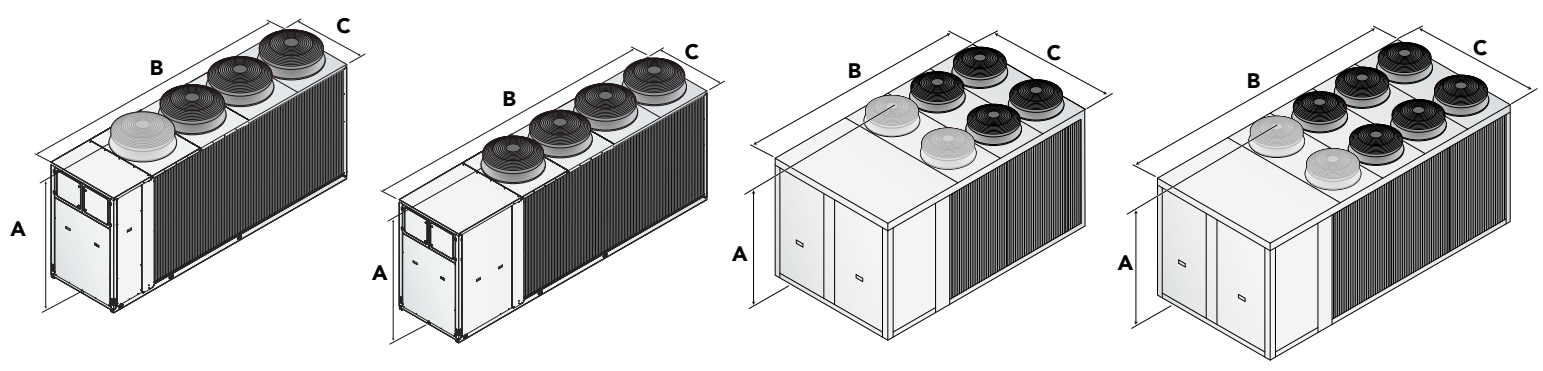

**SA/SE** 2302 - 2502

**SA/SE** 2504 - 3004 - 3204

**SA/SE** 3504 - 4004  
**HA/HE-LS/XL** 2504 - 3004 - 3204 - 3504

**SA/SE** 4504 - 5004  
**HA/HE-LS/XL** 4004 - 4504 - 5004

		1402	1602	1802	2002	2302	2502	2504	3004	3204	3504	4004	4504	5004
A (mm)	SA-SE/LS	1880	1880	2270	2270	2310	2310	2310	2310	2310	2350	2350	2380	2380
B (mm)	SA-SE/LS	3905	3905	3905	3905	4505	4505	5300	5300	5300	4205	4205	4810	4810
C (mm)	SA-SE/LS	1150	1150	1150	1150	1150	1150	1150	1150	1150	2210	2210	2210	2210
kg	SA-SE/LS	1320	1360	1690	1710	1990	2040	2500	2540	2620	3220	3270	3600	3700
A (mm)	HA-HE/LS	1880	1880	1880	1880	2270	2270	2350	2350	2350	2350	2380	2380	2380
B (mm)	HA-HE/LS	3905	3905	3905	3905	3905	3905	4205	4205	4205	4205	4805	4810	4810
C (mm)	HA-HE/LS	1150	1150	1150	1150	1150	1150	2210	2210	2210	2210	2210	2210	2210
kg	HA-HE/LS	1560	1580	1600	1620	1790	1820	3170	3220	3270	3320	3660	3720	3780
A (mm)	HA-HE/XL	1880	1880	1880	1880	2270	2270	2350	2350	2350	2350	2380	2380	2380
B (mm)	HA-HE/XL	3905	3905	3905	3905	3905	3905	4205	4205	4205	4205	4805	4810	4810
C (mm)	HA-HE/XL	1150	1150	1150	1150	1150	1150	2210	2210	2210	2210	2210	2210	2210
kg	HA-HE/XL	1590	1610	1630	1650	1820	1850	3220	3270	3320	3370	3710	3770	3830

# LHE

## HIGH EFFICIENCY AIR TO WATER HEAT PUMPS EQUIPPED WITH SCROLL COMPRESSOR AND AXIAL FANS WITH LOW GWP REFRIGERANT

Heating power from 45 kW to 457 kW

R454B

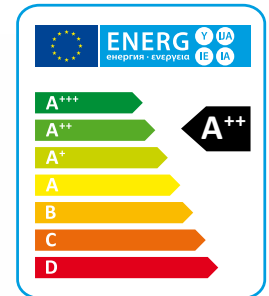

LHE high-efficiency air/water heat pumps are particularly suitable for applications where maximum efficiency in heating mode and a low noise level are required. The units are specifically designed to provide the best efficiency in heating mode; they can operate at outside temperatures down to -20°C and produce water up to a temperature of 60°C.

All sizes are supplied with reverse cycle valve used for winter defrost; the RV versions are also able to produce cold water in summer period (not available for HH versions).

### VERSIONI

- HH** Heating only.
- RV** Reversible heating/cooling.
- HA** High efficiency, AC fans.
- HE** High efficiency, EC fans.
- LS** Low noise.
- XL** Super low noise.
- P2U** 2 pipe systems without domestic hot water production.
- P2S** 2 pipe systems with domestic hot water production by external 3 way valve.

# TECHNICAL DATA

Reversible heating/cooling version (RV)

HA/LS/HH-RV P2U		452	512	682	752	912	1102	1152	1352	1502	1612
Heating capacity (EN14511) <sup>(1)</sup>	kW	45,4	51,4	68,7	74,6	87,9	101,0	112,0	129,0	150,0	161,0
Total input power (EN14511) <sup>(1)</sup>	kW	11,7	13,0	16,3	18,4	22,7	25,3	28,4	33,5	38,4	40,6
COP (EN14511) <sup>(1)</sup>	W/W	3,88	3,95	4,21	4,05	3,87	3,99	3,94	3,85	3,91	3,97
Energy Class <sup>(2)</sup>		A+	A+	A++	A++	A+	A++	A++	A+	A+	A+
SCOP <sup>(2)</sup>	kWh/kWh	3,68	3,74	4,08	4,00	3,52	3,85	3,86	3,69	3,69	3,75
η <sub>s,h</sub> <sup>(2)</sup>	%	144	147	160	157	138	151	151	145	145	147
Cooling capacity (EN14511) <sup>(3)</sup>	kW	37,7	43,2	57,1	61,0	76,7	86,9	96,0	112,0	125,0	136,0
Total input power (EN14511) <sup>(3)</sup>	kW	14,0	16,4	21,3	24,6	26,5	30,3	35,0	38,3	44,3	48,5
EER (EN14511) <sup>(3)</sup>	W/W	2,69	2,63	2,68	2,48	2,89	2,87	2,74	2,92	2,82	2,80
TER (EN14511) <sup>(4)</sup>	W/W	5,58	5,78	6,04	5,82	5,98	5,94	6,04	5,91	5,80	5,92
Sound power <sup>(5)</sup>	dB (A)	77	76	77	78	82	83	85	86	87	87
Sound pressure <sup>(6)</sup>	dB (A)	46	44	45	46	50	51	53	54	55	55
HE/LS/HH-RV P2U		452	512	682	752	912	1102	1152	1352	1502	1612
Heating capacity (EN14511) <sup>(1)</sup>	kW	45,0	51,5	68,7	75,0	91,0	102,0	114,0	134,0	150,0	161,0
Total input power (EN14511) <sup>(1)</sup>	kW	11,2	13,0	16,3	18,4	21,4	24,5	27,0	31,6	36,6	38,9
COP (EN14511) <sup>(1)</sup>	W/W	4,02	3,96	4,21	4,08	4,25	4,16	4,22	4,24	4,10	4,14
Energy Class <sup>(2)</sup>		A++	A++	A++	A++	A++	A++	A++	A++	A++	A++
SCOP <sup>(2)</sup>	kWh/kWh	3,98	3,90	4,19	4,13	3,92	4,10	4,14	4,02	4,08	4,03
η <sub>s,h</sub> <sup>(2)</sup>	%	156	153	165	162	154	161	163	158	160	158
Cooling capacity (EN14511) <sup>(3)</sup>	kW	36,9	43,2	57,6	61,5	76,5	85,5	95,0	112,0	124,0	134,0
Total input power (EN14511) <sup>(3)</sup>	kW	14,1	16,5	21,2	24,5	25,8	30,3	34,6	37,3	43,6	48,1
EER (EN14511) <sup>(3)</sup>	W/W	2,62	2,62	2,72	2,51	2,97	2,82	2,75	3,00	2,84	2,79
TER (EN14511) <sup>(4)</sup>	W/W	6,19	5,78	6,04	5,82	5,98	5,94	6,04	5,91	5,80	5,92
Sound power <sup>(5)</sup>	dB (A)	78	79	81	82	86	87	88	89	89	90
Sound pressure <sup>(6)</sup>	dB (A)	46	47	49	50	54	55	56	57	56	57
Power supply	V/Ph/Hz	400/3/50	400/3/50	400/3/50	400/3/50	400/3/50	400/3/50	400/3/50	400/3/50	400/3/50	400/3/50
Compressors / Circuits	n° / n°	2 / 1	2 / 1	2 / 1	2 / 1	2 / 1	2 / 1	2 / 1	2 / 1	2 / 1	2 / 1
Fans	n°	2	2	2	2	2	2	2	3	3	3
Refrigerant		R454B	R454B	R454B	R454B	R454B	R454B	R454B	R454B	R454B	R454B
Refrigerant charge	kg	11	11	17	17	25	25	25	36	36	36
Global warming potential (GWP)		466	466	466	466	466	466	466	466	466	466
Equivalent CO <sub>2</sub> charge	t	5,1	5,1	7,9	7,9	11,6	11,6	11,6	16,8	16,8	16,8
Water tank volume	l	140	140	300	300	300	300	300	500	500	500

HA/LS/HH-RV P2U		1792	2012	2304	2312	2654	2954	3214	3514	3954	4454
Heating capacity (EN14511) <sup>(1)</sup>	kW	181,0	200,0	226,0	226,0	261,0	297,0	319,0	365,0	404,0	454,0
Total input power (EN14511) <sup>(1)</sup>	kW	45,7	50,0	56,7	56,0	68,5	78,0	82,8	94,1	105,0	116,0
COP (EN14511) <sup>(1)</sup>	W/W	3,96	4,00	3,99	4,04	3,81	3,81	3,85	3,88	3,85	3,91
Energy Class <sup>(2)</sup>		A++	A++	A+	A++	A+	A+	A+	A+	A+	A+
SCOP <sup>(2)</sup>	kWh/kWh	3,99	3,98	3,68	4,04	3,51	3,55	3,69	3,69	3,60	3,63
η <sub>s,h</sub> <sup>(2)</sup>	%	157	156	144	159	137	139	145	145	141	142
Cooling capacity (EN14511) <sup>(3)</sup>	kW	160,0	175,0	197,0	195,0	229,0	254,0	271,0	306,0	352,0	387,0
Total input power (EN14511) <sup>(3)</sup>	kW	57,0	62,8	70,3	69,4	78,3	91,9	100,0	116,0	125,0	141,0
EER (EN14511) <sup>(3)</sup>	W/W	2,81	2,79	2,80	2,81	2,92	2,76	2,71	2,64	2,82	2,74
TER (EN14511) <sup>(4)</sup>	W/W	6,20	6,11	6,01	6,11	5,89	5,77	5,83	5,81	6,76	6,89
Sound power <sup>(5)</sup>	dB (A)	89	89	88	91	89	90	90	92	92	94
Sound pressure <sup>(6)</sup>	dB (A)	57	57	56	58	56	58	58	60	59	62
HE/LS/HH-RV P2U		1792	2012	2304	2312	2654	2954	3214	3514	3954	4454
Heating capacity (EN14511) <sup>(1)</sup>	kW	182,0	202,0	227,0	230,0	261,0	298,0	320,0	366,0	405,0	455,0
Total input power (EN14511) <sup>(1)</sup>	kW	44,1	48,5	54,6	54,3	64,6	74,2	79,0	90,6	100,0	112,0
COP (EN14511) <sup>(1)</sup>	W/W	4,13	4,16	4,16	4,24	4,04	4,02	4,05	4,04	4,05	4,06
Energy Class <sup>(2)</sup>		A++	A++	A++	A++	A++	A++	A++	A++	A++	A++
SCOP <sup>(2)</sup>	kWh/kWh	4,25	4,20	4,12	4,20	3,92	4,01	4,05	4,06	4,04	4,01
η <sub>s,h</sub> <sup>(2)</sup>	%	167	165	162	165	154	157	159	159	159	157
Cooling capacity (EN14511) <sup>(3)</sup>	kW	158,0	173,0	194,0	193,0	227,0	252,0	269,0	304,0	347,0	381,0
Total input power (EN14511) <sup>(3)</sup>	kW	56,9	62,7	69,8	69,6	76,8	90,4	99,0	115,0	124,0	140,0
EER (EN14511) <sup>(3)</sup>	W/W	2,78	2,76	2,78	2,77	2,96	2,79	2,72	2,64	2,80	2,72
TER (EN14511) <sup>(4)</sup>	W/W	6,20	6,11	6,01	6,11	5,89	5,77	5,83	5,81	6,76	6,89
Sound power <sup>(5)</sup>	dB (A)	90	92	91	92	91	92	92	93	91	89
Sound pressure <sup>(6)</sup>	dB (A)	58	59	58	60	58	59	59	60	59	56
Power supply	V/Ph/Hz	400/3/50	400/3/50	400/3/50	400/3/50	400/3/50	400/3/50	400/3/50	400/3/50	400/3/50	400/3/50
Compressors / Circuits	n° / n°	2 / 1	2 / 1	4 / 2	2 / 1	4 / 2	4 / 2	4 / 2	4 / 2	4 / 2	4 / 2
Fans	n°	3	3	4	3	6	6	6	6	8	8
Refrigerant		R454B	R454B	R454B	R454B	R454B	R454B	R454B	R454B	R454B	R454B
Refrigerant charge	kg	37	47	25	59	32	32	32	31	37	41
Global warming potential (GWP)		466	466	466	466	466	466	466	466	466	466
Equivalent CO <sub>2</sub> charge	t	17,2	21,9	11,6	27,5	14,9	14,9	14,9	14,4	17,2	19,1
Water tank volume	l	500	500	500	500	500	500	500	500	500	500

Performances are referred to the following conditions:

(1) Heating: Ambient temperature 7°C DB, 6°C WB, water temperature 30/35°C.

(2) Average conditions, low temperature, variable - Reg EU 811/2013

(3) Cooling: ambient air temperature 35°C, evaporator water temperature in/out 12/7 °C (only rv versions).

(4) TER: Total Energy Ratio - cold circuit 12/7°C, hot circuit 30/35°C.

(5) Sound power level in accordance with ISO 3744.

(6) Sound pressure level at 10 mt from the unit in free field conditions in accordance with ISO 3744.

Reversible heating/cooling version (RV)

HE

HA/XL/HH-RV P2U		452	512	682	752	912	1102	1152	1352	1502	1612
Heating capacity (EN14511) <sup>(1)</sup>	kW	45,2	51,0	67,6	73,6	89,9	102,0	112,0	133,0	148,0	160,0
Total input power (EN14511) <sup>(1)</sup>	kW	11,5	13,0	16,2	18,2	22,2	25,0	27,6	32,8	37,9	39,9
COP (EN14511) <sup>(1)</sup>	W/W	3,93	3,92	4,17	4,04	4,05	4,08	4,06	4,05	3,91	4,01
Energy Class <sup>(2)</sup>		A++	A++	A++	A++	A+	A++	A++	A++	A++	A++
SCOP <sup>(2)</sup>	kWh/kWh	3,88	3,97	4,07	4,02	3,79	4,12	4,14	3,98	3,95	4,02
η <sub>s,h</sub> <sup>(2)</sup>	%	152	156	160	158	149	162	163	156	155	158
Cooling capacity (EN14511) <sup>(3)</sup>	kW	37,0	42,5	56,1	59,0	75,3	84,5	93,3	111,0	122,0	132,0
Total input power (EN14511) <sup>(3)</sup>	kW	14,3	16,7	21,7	25,6	26,7	31,0	35,8	38,3	45,4	49,6
EER (EN14511) <sup>(3)</sup>	W/W	2,59	2,54	2,59	2,30	2,82	2,73	2,61	2,90	2,69	2,66
TER (EN14511) <sup>(4)</sup>	W/W	5,58	5,78	6,04	5,82	5,98	5,94	6,04	5,91	5,80	5,92
Sound power <sup>(5)</sup>	dB (A)	72	71	71	72	74	76	78	80	81	81
Sound pressure <sup>(6)</sup>	dB (A)	40	40	40	41	43	44	46	48	49	49
HE/XL/HH-RV P2U		452	512	682	752	912	1102	1152	1352	1502	1612
Heating capacity (EN14511) <sup>(1)</sup>	kW	44,6	51,2	68,2	74,1	89,4	101,0	111,0	132,0	148,0	158,0
Total input power (EN14511) <sup>(1)</sup>	kW	11,0	12,8	16,1	18,1	20,7	23,6	26,2	30,6	35,3	37,5
COP (EN14511) <sup>(1)</sup>	W/W	4,05	4,00	4,24	4,09	4,32	4,28	4,24	4,31	4,19	4,21
Energy Class <sup>(2)</sup>		A++	A++	A++	A++	A++	A++	A++	A++	A++	A++
SCOP <sup>(2)</sup>	kWh/kWh	4,00	4,02	4,19	4,13	4,24	4,35	4,39	4,29	4,27	4,24
η <sub>s,h</sub> <sup>(2)</sup>	%	157	158	165	162	167	171	173	169	168	167
Cooling capacity (EN14511) <sup>(3)</sup>	kW	35,9	42,3	56,0	59,4	73,3	82,1	90,6	108,0	119,0	129,0
Total input power (EN14511) <sup>(3)</sup>	kW	14,2	16,5	21,5	25,0	26,1	30,7	35,4	37,4	44,3	48,6
EER (EN14511) <sup>(3)</sup>	W/W	2,53	2,56	2,60	2,38	2,81	2,67	2,56	2,89	2,69	2,65
TER (EN14511) <sup>(4)</sup>	W/W	6,19	5,78	6,04	5,82	5,98	5,94	6,04	5,91	5,80	5,92
Sound power <sup>(5)</sup>	dB (A)	72	71	71	72	74	76	78	80	81	81
Sound pressure <sup>(6)</sup>	dB (A)	40	40	40	41	43	44	46	48	49	49
Power supply	V/Ph/Hz	400/3/50	400/3/50	400/3/50	400/3/50	400/3/50	400/3/50	400/3/50	400/3/50	400/3/50	400/3/50
Compressors / Circuits	n° / n°	2 / 1	2 / 1	2 / 1	2 / 1	2 / 1	2 / 1	2 / 1	2 / 1	2 / 1	2 / 1
Fans	n°	2	2	2	2	2	2	2	3	3	3
Refrigerant		R454B	R454B	R454B	R454B	R454B	R454B	R454B	R454B	R454B	R454B
Refrigerant charge	kg	11	11	17	17	25	25	25	36	36	36
Global warming potential (GWP)		466	466	466	466	466	466	466	466	466	466
Equivalent CO <sub>2</sub> charge	t	5,1	5,1	7,9	7,9	11,6	11,6	11,6	16,8	16,8	16,8
Water tank volume	l	140	140	300	300	300	300	300	500	500	500
HA/XL/HH-RV P2U		1792	2012	2304	2312	2654	2954	3214	3514	3954	4454
Heating capacity (EN14511) <sup>(1)</sup>	kW	181,0	200,0	229,0	227,0	267,0	300,0	320,0	365,0	407,0	456,0
Total input power (EN14511) <sup>(1)</sup>	kW	44,2	49,3	55,9	55,0	66,8	76,6	80,9	92,0	101,0	113,0
COP (EN14511) <sup>(1)</sup>	W/W	4,10	4,06	4,10	4,13	4,00	3,92	3,96	3,97	4,03	4,04
Energy Class <sup>(2)</sup>		A++	A++	A++	A++	A+	A+	A++	A++	A++	A++
SCOP <sup>(2)</sup>	kWh/kWh	4,09	4,09	3,86	4,09	3,82	3,79	3,89	3,88	3,85	3,84
η <sub>s,h</sub> <sup>(2)</sup>	%	161	161	151	161	150	149	153	152	151	151
Cooling capacity (EN14511) <sup>(3)</sup>	kW	154,0	171,0	191	188,0	222,0	247,0	263,0	294,0	342,0	374,0
Total input power (EN14511) <sup>(3)</sup>	kW	58,9	64,0	72,4	72,2	80,1	94,0	103,0	121,0	128,0	145,0
EER (EN14511) <sup>(3)</sup>	W/W	2,61	2,67	2,65	2,60	2,77	2,63	2,55	2,43	2,67	2,58
TER (EN14511) <sup>(4)</sup>	W/W	6,20	6,11	6,01	6,11	5,89	5,77	5,83	5,81	6,76	6,76
Sound power <sup>(5)</sup>	dB (A)	81	82	80	83	83	84	84	84	86	86
Sound pressure <sup>(6)</sup>	dB (A)	49	51	49	52	51	52	52	52	53	54
HE/XL/HH-RV P2U		1792	2012	2304	2312	2654	2954	3214	3514	3954	4454
Heating capacity (EN14511) <sup>(1)</sup>	kW	179,0	199,0	222,0	225,0	260,0	291,0	312,0	352,0	395,0	434,0
Total input power (EN14511) <sup>(1)</sup>	kW	42,5	47,0	52,9	52,9	62,0	71,5	76,0	86,8	95,6	107,0
COP (EN14511) <sup>(1)</sup>	W/W	4,21	4,23	4,20	4,25	4,19	4,07	4,11	4,06	4,13	4,06
Energy Class <sup>(2)</sup>		A++	A++	A++	A++	A++	A++	A++	A++	A++	A++
SCOP <sup>(2)</sup>	kWh/kWh	4,33	4,33	4,37	4,31	4,14	4,18	4,18	4,19	4,20	4,07
η <sub>s,h</sub> <sup>(2)</sup>	%	170	170	172	169	163	164	164	165	165	160
Cooling capacity (EN14511) <sup>(3)</sup>	kW	150,0	165,0	186,0	181,0	218,0	242,0	257,0	284,0	335,0	364,0
Total input power (EN14511) <sup>(3)</sup>	kW	58,7	64,6	71,3	73,4	77,0	91,2	101,0	120,0	125,0	144,0
EER (EN14511) <sup>(3)</sup>	W/W	2,56	2,55	2,61	2,47	2,83	2,65	2,54	2,37	2,68	2,53
TER (EN14511) <sup>(4)</sup>	W/W	6,20	6,11	6,01	6,11	5,89	5,77	5,83	5,81	6,76	6,89
Sound power <sup>(5)</sup>	dB (A)	81	82	80	83	83	84	84	84	86	86
Sound pressure <sup>(6)</sup>	dB (A)	49	51	49	52	51	52	52	52	53	54
Power supply	V/Ph/Hz	400/3/50	400/3/50	400/3/50	400/3/50	400/3/50	400/3/50	400/3/50	400/3/50	400/3/50	400/3/50
Compressors / Circuits	n° / n°	2 / 1	2 / 1	4 / 2	2 / 1	4 / 2	4 / 2	4 / 2	4 / 2	4 / 2	4 / 2
Fans	n°	3	3	4	3	6	6	6	6	8	8
Refrigerant		R454B	R454B	R454B	R454B	R454B	R454B	R454B	R454B	R454B	R454B
Refrigerant charge	kg	37	47	25	59	32	32	32	31	37	41
Global warming potential (GWP)		466	466	466	466	466	466	466	466	466	466
Equivalent CO <sub>2</sub> charge	t	17,2	21,9	11,6	27,5	14,9	14,9	14,9	14,4	17,2	19,1
Water tank volume	l	500	500	500	500	500	500	500	500	500	500

Performances are referred to the following conditions:

(1) Heating: Ambient temperature 7°C DB, 6°C WB, water temperature 30/35°C.

(2) Average conditions, low temperature, variable - Reg EU 811/2013

(3) Cooling: ambient air temperature 35°C, evaporator water temperature in/out 12/7 °C (only rv versions).

(4) TER: Total Energy Ratio - cold circuit 12/7°C, hot circuit 30/35°C.

(5) Sound power level in accordance with ISO 3744.

(6) Sound pressure level at 10 mt from the unit in free field conditions in accordance with ISO 3744.

Reversible heating/cooling version (RV)

<b>HA/LS/HH-RV P2S</b>		<b>452</b>	<b>512</b>	<b>682</b>	<b>752</b>	<b>912</b>	<b>1102</b>	<b>1152</b>	<b>1352</b>	<b>1502</b>	<b>1612</b>
Heating capacity (EN14511) <sup>(1)</sup>	kW	45,4	51,4	68,7	74,6	87,9	101,0	112,0	129,0	150,0	161,0
Total input power (EN14511) <sup>(1)</sup>	kW	11,7	13,0	16,3	18,4	22,7	25,3	28,4	33,5	38,4	40,6
COP (EN14511) <sup>(1)</sup>	W/W	3,88	3,95	4,21	4,05	3,87	3,99	3,94	3,85	3,91	3,97
Energy Class <sup>(2)</sup>		A+	A+	A++	A++	A+	A++	A++	A+	A+	A+
SCOP <sup>(2)</sup>	kWh/kWh	3,68	3,74	4,08	4,00	3,52	3,85	3,86	3,69	3,69	3,75
η <sub>s,h</sub> <sup>(2)</sup>	%	144	147	160	157	138	151	151	145	145	147
Cooling capacity (EN14511) <sup>(3)</sup>	kW	37,7	43,2	57,1	61,0	76,7	86,9	96,0	112,0	125,0	136,0
Total input power (EN14511) <sup>(3)</sup>	kW	14,0	16,4	21,3	24,6	26,5	30,3	35,0	38,3	44,3	48,5
EER (EN14511) <sup>(3)</sup>	W/W	2,69	2,63	2,68	2,48	2,89	2,87	2,74	2,92	2,82	2,80
TER (EN14511) <sup>(4)</sup>	W/W	5,58	5,78	6,04	5,82	5,98	5,94	6,04	5,91	5,80	5,92
Sound power <sup>(5)</sup>	dB (A)	77	76	77	78	82	83	85	86	87	87
Sound pressure <sup>(6)</sup>	dB (A)	46	44	45	46	50	51	53	54	55	55
<b>HE/LS/HH-RV P2S</b>		<b>452</b>	<b>512</b>	<b>682</b>	<b>752</b>	<b>912</b>	<b>1102</b>	<b>1152</b>	<b>1352</b>	<b>1502</b>	<b>1612</b>
Heating capacity (EN14511) <sup>(1)</sup>	kW	45,0	51,5	68,7	75,0	91,0	102,0	114,0	134,0	150,0	161,0
Total input power (EN14511) <sup>(1)</sup>	kW	11,2	13,0	16,3	18,4	21,4	24,5	27,0	31,6	36,6	38,9
COP (EN14511) <sup>(1)</sup>	W/W	4,02	3,96	4,21	4,08	4,25	4,16	4,22	4,24	4,10	4,14
Energy Class <sup>(2)</sup>		A++	A++	A++	A++	A++	A++	A++	A++	A++	A++
SCOP <sup>(2)</sup>	kWh/kWh	3,98	3,90	4,19	4,13	3,92	4,10	4,14	4,02	4,08	4,03
η <sub>s,h</sub> <sup>(2)</sup>	%	156	153	165	162	154	161	163	158	160	158
Cooling capacity (EN14511) <sup>(3)</sup>	kW	36,9	43,2	57,6	61,5	76,5	85,5	95,0	112,0	124,0	134,0
Total input power (EN14511) <sup>(3)</sup>	kW	14,1	16,5	21,2	24,5	25,8	30,3	34,6	37,3	43,6	48,1
EER (EN14511) <sup>(3)</sup>	W/W	2,62	2,62	2,72	2,51	2,97	2,82	2,75	3,00	2,84	2,79
TER (EN14511) <sup>(4)</sup>	W/W	6,19	5,78	6,04	5,82	5,98	5,94	6,04	5,91	5,80	5,92
Sound power <sup>(5)</sup>	dB (A)	78	79	81	82	86	87	88	89	89	90
Sound pressure <sup>(6)</sup>	dB (A)	46	47	49	50	54	55	56	57	56	57
Power supply	V/Ph/Hz	400/3/50	400/3/50	400/3/50	400/3/50	400/3/50	400/3/50	400/3/50	400/3/50	400/3/50	400/3/50
Compressors / Circuits	n° / n°	2 / 1	2 / 1	2 / 1	2 / 1	2 / 1	2 / 1	2 / 1	2 / 1	2 / 1	2 / 1
Fans	n°	2	2	2	2	2	2	2	3	3	3
Refrigerant		R454B	R454B	R454B	R454B	R454B	R454B	R454B	R454B	R454B	R454B
Refrigerant charge	kg	11	11	17	17	25	25	25	36	36	36
Global warming potential (GWP)		466	466	466	466	466	466	466	466	466	466
Equivalent CO <sub>2</sub> charge	t	5,1	5,1	7,9	7,9	11,6	11,6	11,6	16,8	16,8	16,8
Water tank volume	l	140	140	300	300	300	300	300	500	500	500
<b>HA/LS/HH-RV P2S</b>		<b>1792</b>	<b>2012</b>	<b>2304</b>	<b>2312</b>	<b>2654</b>	<b>2954</b>	<b>3214</b>	<b>3514</b>	<b>3954</b>	<b>4454</b>
Heating capacity (EN14511) <sup>(1)</sup>	kW	181,0	200,0	226,0	226,0	261,0	297,0	319,0	365,0	404,0	454,0
Total input power (EN14511) <sup>(1)</sup>	kW	45,7	50,0	56,7	56,0	68,5	78,0	82,8	94,1	105,0	116,0
COP (EN14511) <sup>(1)</sup>	W/W	3,96	4,00	3,99	4,04	3,81	3,81	3,85	3,88	3,85	3,91
Energy Class <sup>(2)</sup>		A++	A++	A+	A++	A+	A+	A+	A+	A+	A+
SCOP <sup>(2)</sup>	kWh/kWh	3,99	3,98	3,68	4,04	3,51	3,55	3,69	3,69	3,60	3,63
η <sub>s,h</sub> <sup>(2)</sup>	%	157	156	144	159	137	139	145	145	141	142
Cooling capacity (EN14511) <sup>(3)</sup>	kW	160,0	175,0	197,0	195,0	229,0	254,0	271,0	306,0	352,0	387,0
Total input power (EN14511) <sup>(3)</sup>	kW	57,0	62,8	70,3	69,4	78,3	91,9	100,0	116,0	125,0	141,0
EER (EN14511) <sup>(3)</sup>	W/W	2,81	2,79	2,80	2,81	2,92	2,76	2,71	2,64	2,82	2,74
TER (EN14511) <sup>(4)</sup>	W/W	6,20	6,11	6,01	6,11	5,89	5,77	5,83	5,81	6,76	6,89
Sound power <sup>(5)</sup>	dB (A)	89	89	88	91	89	90	90	92	92	94
Sound pressure <sup>(6)</sup>	dB (A)	57	57	56	58	56	58	58	60	59	62
<b>HE/LS/HH-RV P2S</b>		<b>1792</b>	<b>2012</b>	<b>2304</b>	<b>2312</b>	<b>2654</b>	<b>2954</b>	<b>3214</b>	<b>3514</b>	<b>3954</b>	<b>4454</b>
Heating capacity (EN14511) <sup>(1)</sup>	kW	182,0	202,0	227,0	230,0	261,0	298,0	320,0	366,0	405,0	455,0
Total input power (EN14511) <sup>(1)</sup>	kW	44,1	48,5	54,6	54,3	64,6	74,2	79,0	90,6	100,0	112,0
COP (EN14511) <sup>(1)</sup>	W/W	4,13	4,16	4,16	4,24	4,04	4,02	4,05	4,04	4,05	4,06
Energy Class <sup>(2)</sup>		A++	A++	A++	A++	A++	A++	A++	A++	A++	A++
SCOP <sup>(2)</sup>	kWh/kWh	4,25	4,20	4,12	4,20	3,92	4,01	4,05	4,06	4,04	4,01
η <sub>s,h</sub> <sup>(2)</sup>	%	167	165	162	165	154	157	159	159	159	157
Cooling capacity (EN14511) <sup>(3)</sup>	kW	158,0	173,0	194	193,0	227,0	252,0	269,0	304,0	349,0	384,0
Total input power (EN14511) <sup>(3)</sup>	kW	56,9	62,7	69,8	69,6	76,8	90,4	99,0	115,0	124,0	140,0
EER (EN14511) <sup>(3)</sup>	W/W	2,78	2,76	2,78	2,72	2,96	2,79	2,72	2,64	2,81	2,74
TER (EN14511) <sup>(4)</sup>	W/W	6,20	6,11	6,01	6,11	5,89	5,77	5,83	5,81	6,76	6,89
Sound power <sup>(5)</sup>	dB (A)	90	92	91	92	91	92	92	93	91	89
Sound pressure <sup>(6)</sup>	dB (A)	58	59	58	60	58	59	59	60	59	56
Power supply	V/Ph/Hz	400/3/50	400/3/50	400/3/50	400/3/50	400/3/50	400/3/50	400/3/50	400/3/50	400/3/50	400/3/50
Compressors / Circuits	n° / n°	2 / 1	2 / 1	4 / 2	2 / 1	4 / 2	4 / 2	4 / 2	4 / 2	4 / 2	4 / 2
Fans	n°	3	3	4	3	6	6	6	6	8	8
Refrigerant		R454B	R454B	R454B	R454B	R454B	R454B	R454B	R454B	R454B	R454B
Refrigerant charge	kg	37	47	25	59	32	32	32	31	37	41
Global warming potential (GWP)		466	466	466	466	466	466	466	466	466	466
Equivalent CO <sub>2</sub> charge	t	17,2	21,9	11,6	27,5	14,9	14,9	14,9	14,4	17,2	19,1
Water tank volume	l	500	500	500	500	500	500	500	500	500	500

Performances are referred to the following conditions:

(1) Heating: Ambient temperature 7°C DB, 6°C WB, water temperature 30/35°C.

(2) Average conditions, low temperature, variable - Reg EU 811/2013

(3) Cooling: ambient air temperature 35°C, evaporator water temperature in/out 12/7 °C (only rv versions).

(4) TER: Total Energy Ratio - cold circuit 12/7°C, hot circuit 30/35°C.

(5) Sound power level in accordance with ISO 3744.

(6) Sound pressure level at 10 mt from the unit in free field conditions in accordance with ISO 3744.

Reversible heating/cooling version (RV)

HE

HA/XL/HH-RV P2S		452	512	682	752	912	1102	1152	1352	1502	1612
Heating capacity (EN14511) <sup>(1)</sup>	kW	45,2	51,0	67,6	73,6	89,9	102,0	112,0	133,0	148,0	160,0
Total input power (EN14511) <sup>(1)</sup>	kW	11,5	13,0	16,2	18,2	22,2	25,0	27,6	32,8	37,9	39,9
COP (EN14511) <sup>(1)</sup>	W/W	3,93	3,92	4,17	4,04	4,05	4,08	4,06	4,05	3,91	4,01
Energy Class <sup>(2)</sup>		A++	A++	A++	A++	A+	A++	A++	A++	A++	A++
SCOP <sup>(2)</sup>	kWh/kWh	3,88	3,97	4,07	4,02	3,79	4,12	4,14	3,98	3,95	4,02
$\eta_{s,h}$ <sup>(2)</sup>	%	152	156	160	158	149	162	163	156	155	158
Cooling capacity (EN14511) <sup>(3)</sup>	kW	37,0	42,5	56,1	59,0	75,3	84,5	93,3	111,0	122,0	132,0
Total input power (EN14511) <sup>(3)</sup>	kW	14,3	16,7	21,7	25,6	26,7	31,0	35,8	38,3	45,4	49,6
EER (EN14511) <sup>(3)</sup>	W/W	2,59	2,54	2,59	2,30	2,82	2,73	2,61	2,90	2,69	2,66
TER (EN14511) <sup>(4)</sup>	W/W	5,58	5,78	6,04	5,82	5,98	5,94	6,04	5,91	5,80	5,92
Sound power <sup>(5)</sup>	dB (A)	72	71	71	72	74	76	78	80	81	81
Sound pressure <sup>(6)</sup>	dB (A)	40	40	40	41	43	44	46	48	49	49
HE/XL/HH-RV P2S		452	512	682	752	912	1102	1152	1352	1502	1612
Heating capacity (EN14511) <sup>(1)</sup>	kW	44,6	51,2	68,2	74,1	89,5	101,0	111,0	132,0	148,0	158,0
Total input power (EN14511) <sup>(1)</sup>	kW	11,0	12,7	16,0	18,0	20,6	23,6	26,0	30,5	35,3	37,4
COP (EN14511) <sup>(1)</sup>	W/W	4,05	4,03	4,26	4,12	4,34	4,28	4,27	4,33	4,19	4,22
Energy Class <sup>(2)</sup>		A++	A++	A++	A++	A++	A++	A++	A++	A++	A++
SCOP <sup>(2)</sup>	kWh/kWh	4,00	4,02	4,19	4,13	4,24	4,35	4,39	4,29	4,27	4,24
$\eta_{s,h}$ <sup>(2)</sup>	%	157	158	165	162	167	171	173	169	168	167
Cooling capacity (EN14511) <sup>(3)</sup>	kW	36,3	42,6	56,3	59,8	73,8	82,7	91,2	108,0	120,0	130,0
Total input power (EN14511) <sup>(3)</sup>	kW	14,2	16,5	21,5	25,1	26,1	30,7	35,5	37,5	44,5	48,7
EER (EN14511) <sup>(3)</sup>	W/W	2,56	2,58	2,62	2,38	2,83	2,69	2,57	2,88	2,70	2,67
TER (EN14511) <sup>(4)</sup>	W/W	6,19	5,78	6,04	5,82	5,98	5,94	6,04	5,91	5,80	5,92
Sound power <sup>(5)</sup>	dB (A)	72	71	71	72	74	76	78	80	81	81
Sound pressure <sup>(6)</sup>	dB (A)	40	40	40	41	43	44	46	48	49	49
Power supply	V/Ph/Hz	400/3/50	400/3/50	400/3/50	400/3/50	400/3/50	400/3/50	400/3/50	400/3/50	400/3/50	400/3/50
Compressors / Circuits	n° / n°	2 / 1	2 / 1	2 / 1	2 / 1	2 / 1	2 / 1	2 / 1	2 / 1	2 / 1	2 / 1
Fans	n°	2	2	2	2	2	2	2	3	3	3
Refrigerant		R454B	R454B	R454B	R454B	R454B	R454B	R454B	R454B	R454B	R454B
Refrigerant charge	kg	11	11	17	17	25	25	25	36	36	36
Global warming potential (GWP)		466	466	466	466	466	466	466	466	466	466
Equivalent CO <sub>2</sub> charge	t	5,1	5,1	7,9	7,9	11,6	11,6	11,6	16,8	16,8	16,8
Water tank volume	l	140	140	300	300	300	300	300	500	500	500

HA/XL/HH-RV P2S		1792	2012	2304	2312	2654	2954	3214	3514	3954	4454
Heating capacity (EN14511) <sup>(1)</sup>	kW	181,0	200,0	229,0	227,0	267,0	300,0	320,0	365,0	407,0	456,0
Total input power (EN14511) <sup>(1)</sup>	kW	44,2	49,3	55,9	55,0	66,8	76,6	80,9	92,0	101,0	113,0
COP (EN14511) <sup>(1)</sup>	W/W	4,10	4,06	4,10	4,13	4,00	3,92	3,96	3,97	4,03	4,04
Energy Class <sup>(2)</sup>		A++	A++	A++	A++	A+	A+	A++	A++	A++	A++
SCOP <sup>(2)</sup>	kWh/kWh	4,09	4,09	3,86	4,09	3,82	3,79	3,89	3,88	3,85	3,84
$\eta_{s,h}$ <sup>(2)</sup>	%	161	161	151	161	150	149	153	152	151	151
Cooling capacity (EN14511) <sup>(3)</sup>	kW	154,0	171,0	191	188,0	222,0	247,0	263,0	294,0	342,0	374,0
Total input power (EN14511) <sup>(3)</sup>	kW	58,9	64,0	72,4	72,2	80,1	94,0	103,0	121,0	128,0	145,0
EER (EN14511) <sup>(3)</sup>	W/W	2,61	2,67	2,65	2,60	2,77	2,63	2,55	2,43	2,67	2,58
TER (EN14511) <sup>(4)</sup>	W/W	6,20	6,11	6,01	6,11	5,89	5,77	5,83	5,81	6,76	6,76
Sound power <sup>(5)</sup>	dB (A)	81	82	80	83	83	84	84	84	86	86
Sound pressure <sup>(6)</sup>	dB (A)	49	51	49	52	51	52	52	52	53	54
HE/XL/HH-RV P2S		1792	2012	2304	2312	2654	2954	3214	3514	3954	4454
Heating capacity (EN14511) <sup>(1)</sup>	kW	179,0	199,0	222,0	225,0	260,0	291,0	312,0	351,0	396,0	434,0
Total input power (EN14511) <sup>(1)</sup>	kW	42,1	47,0	52,7	52,7	61,6	71,7	75,9	87,0	95,3	107,0
COP (EN14511) <sup>(1)</sup>	W/W	4,25	4,23	4,21	4,27	4,22	4,06	4,11	4,03	4,16	4,06
Energy Class <sup>(2)</sup>		A++	A++	A++	A++	A++	A++	A++	A++	A++	A++
SCOP <sup>(2)</sup>	kWh/kWh	4,33	4,33	4,37	4,31	4,14	4,18	4,18	4,19	4,20	4,07
$\eta_{s,h}$ <sup>(2)</sup>	%	170	170	172	169	163	164	164	165	165	160
Cooling capacity (EN14511) <sup>(3)</sup>	kW	151,0	166,0	187,0	181,0	219,0	244,0	259,0	286,0	337,0	367,0
Total input power (EN14511) <sup>(3)</sup>	kW	58,8	64,7	71,2	73,6	77,2	91,4	101,0	120,0	125,0	143,0
EER (EN14511) <sup>(3)</sup>	W/W	2,57	2,57	2,63	2,46	2,84	2,67	2,56	2,38	2,70	2,57
TER (EN14511) <sup>(4)</sup>	W/W	6,20	6,11	6,01	6,11	5,89	5,77	5,83	5,81	6,76	6,89
Sound power <sup>(5)</sup>	dB (A)	81	82	80	83	83	84	84	84	86	86
Sound pressure <sup>(6)</sup>	dB (A)	49	51	49	52	51	52	52	52	53	54
Power supply	V/Ph/Hz	400/3/50	400/3/50	400/3/50	400/3/50	400/3/50	400/3/50	400/3/50	400/3/50	400/3/50	400/3/50
Compressors / Circuits	n° / n°	2 / 1	2 / 1	4 / 2	2 / 1	4 / 2	4 / 2	4 / 2	4 / 2	4 / 2	4 / 2
Fans	n°	3	3	4	3	6	6	6	6	8	8
Refrigerant		R454B	R454B	R454B	R454B	R454B	R454B	R454B	R454B	R454B	R454B
Refrigerant charge	kg	37	47	25	59	32	32	32	31	37	41
Global warming potential (GWP)		466	466	466	466	466	466	466	466	466	466
Equivalent CO <sub>2</sub> charge	t	17,2	21,9	11,6	27,5	14,9	14,9	14,9	14,4	17,2	19,1
Water tank volume	l	500	500	500	500	500	500	500	500	500	500

Performances are referred to the following conditions:

(1) Heating: Ambient temperature 7°C DB, 6°C WB, water temperature 30/35°C.

(2) Average conditions, low temperature, variable - Reg EU 811/2013

(3) Cooling: ambient air temperature 35°C, evaporator water temperature in/out 12/7 °C (only rv versions).

(4) TER: Total Energy Ratio - cold circuit 12/7°C, hot circuit 30/35°C.

(5) Sound power level in accordance with ISO 3744.

(6) Sound pressure level at 10 mt from the unit in free field conditions in accordance with ISO 3744.

## COMPONENTS

### FRAME

All units are made from hot-galvanised sheet steel, painted with polyurethane powder enamel and stoved at 180°C to provide maximum protection against corrosion. The frame is self-supporting with removable panels. All screws and rivets used are made from stainless steel. The standard colour of the units is RAL9018.

### REFRIGERANT CIRCUIT

The refrigerant circuit is assembled using internationally recognised brand name components with all brazing and welding being performed in accordance with ISO 97/23. The refrigerant utilised is R454B. The refrigerant circuit includes: sight glass, filter drier, electronic expansion valves, 4 way reversing valve, check valves, liquid receiver, liquid separator, schrader valves for maintenance and control, pressure safety device (for compliance with PED regulations).

### COMPRESSORS

The compressors are scroll type, with crankcase resistance and thermal protection, installed in a separate compartment from the airflow in order to reduce noise. When the unit is on stand-by mode, the crankcase heater is always powered. Through the unit's front panel, it is possible to inspect and repair the compressors even when the unit is running.

The compressors used are tandem type. This solution allows a significantly higher efficiency with partial loads compared to the option with independent refrigerant circuits. The control system constantly monitors the discharge temperature of the single compressors.

### SOURCE HEAT EXCHANGER

The source heat exchanger is made from 3/8" copper pipes and 0,1mm at least thick aluminium fins with the tubes being mechanically expanded into the aluminium fins in order to maximise heat transfer. Furthermore, the design guarantees a low air side pressure drop thus enabling the use of low rotation speed (and hence low noise) fans. All heat exchangers are supplied standard with fins hydrophilic coating "Blue Fins".

### USER CIRCUIT HEAT EXCHANGERS

The user heat exchanger is a braze welded, plate type heat exchanger, manufactured from AISI 316 stainless steel. The use of this type of exchanger results in a massive reduction of the refrigerant charge of the unit compared to a traditional shell-in-tube type. A further advantage is a reduction in the overall dimensions of the unit. The exchangers are factory insulated with flexible close cell material and can be fitted with an antifreeze heater (accessory). Each exchanger is fitted with a temperature sensor on the discharge water side for antifreeze protection.

### FANS

The fans are direct drive axial type with aerofoil blades, are statically and dynamically balanced and are supplied complete with a safety fan guard complying with the requirements of EN 60335. They are fixed to the unit frame via rubber anti-vibration mountings. The electric motors, in HA versions are 6 poles type and a phase-cut regulator controls their speed of rotation to increase energy efficiency and allow them to be used over a wider operating range. In the HE versions, the fans are electronic type, with permanent magnet motors with an integrated driver that modulates the speed of rotation. The motors are fitted with integrated thermal overload protection and have a moisture protection rating of IP 54.

### MICROPROCESSORS

All units are supplied as standard with microprocessor controls. The microprocessor controls the following functions: control of the water temperature, antifreeze protection, compressor timing, compressor automatic starting sequence (For multiple compressors), alarm reset.

The control panel is supplied with display showing all operational icons. The microprocessor is set for automatic defrost (when operating in severe ambient conditions) and for summer/ winter change over. The control also manages the integration with other heating sources (electric heaters, boilers, solar panels etc) and both the heating circuit pump and the domestic hot water circuit pump. If required (available as an option), the microprocessor can be configured in order for it to connect to a site BMS system thus enabling remote control and management.

### ELECTRIC ENCLOSURE

The enclosure is manufactured in order to comply with the requirements of the electromagnetic compatibility standards 2014/35/UE and 2014/30/UE. Access to the enclosure is achieved by removing the front panel of the unit. The following components are supplied as standard on all units: main switch, a sequence relay that disables the power supply in the event that the phase sequence is incorrect (scroll compressors can be damaged if they rotate in the wrong direction), thermal overloads (protection of pumps and fans), compressor fuses, control circuit automatic breakers, compressor contactors, fan contactors and pump contactors. The terminal board has volt free contacts for remote ON-OFF, Summer/ winter change over (heat pumps only) and general alarm.

### CONTROL AND PROTECTION DEVICES

All units are standardly equipped with several control and safety devices: water return temperature sensor, installed on the water return pipe of the system, and anti-freeze probe, installed on the water supply pipe to the system high-pressure switch with automatic reset. There are also included a low-pressure automatic reset, pressure transducer (used to optimize the defrosting cycle and modulate the rotation speed of the fans according to external conditions), Freon side safety device, compressor thermal protection, fan thermal protection, flow switch, and external air compensation probe.

### LEAK DETECTOR

When the unit is powered ON, the sensor is warmed up/initialised (duration approx. 1min.).

During this period, the LEDs inside the sensor blink, the refrigerant leakage alarm is notified and the 24Vac auxiliary circuit is switched off. After this period, if in the absence of any further feedback from the sensor, the PLC control is powered up and the unit is ready to operate. If refrigerant leaks occur, the sensor is activated and the power supply to the control PLC is immediately switched off until the sensor indicates the refrigerant is still present.



**VERSION**

**HA/XL HE/XL Super low noise version**

All XL super silenced units are supplied equipped with a special vibration-damping system consisting of a floating basement placed upon the unit's frame, through the interposition of high-damping steel springs. The compressors are housed on this floating base and are in turn fixed by means of rubber anti-vibration supports. The enclosure is manufactured from galvanized steel sandwich panels that have a micro-perforated inner skin and a core of 30 mm thick, high density (25 kg/m<sup>3</sup>) soundproofing mat. The entire arrangement provides a double damping system and acoustic attenuation. The compressor refrigerant pipes are connected to the refrigerant circuit through "anaconda" flexible connections. Flexible connections are also used on the water pipework within the unit. The combination of these systems results in an overall noise reduction in the region of 6-8 dB(A) compared to units in standard configuration.

**HH Version**

HH heating only versions are available in the P2U and P2S configuration only.

**RV Version**

This version uses 2 hydraulic connections and is able to produce hot water in winter and cold water in summer. The unit is combined with a 2-pipe system.

**HA Version**

High efficiency version, according to current standard. Unit equipped with AC fans.

**HE Version**

High efficiency version, according to current standard. Unit equipped with EC fans.

**LS Version**

This version includes the complete acoustic insulation of the unit with compressor jackets and insulating material made with high density media and the interposition of heavy bitumen layer.

**P2U Version**

This is a two pipe version that can produce hot water for heating (HH heating only) and hot or cold water in the RV version. The RV is used with two pipe water based change-over systems. It is not able to produce domestic hot water.

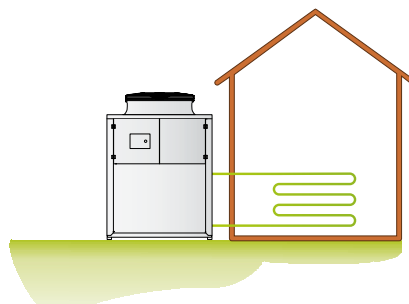

**P2S Version**

This is a two pipe version that can, in addition to producing hot water for heating and cold water for cooling, also generate domestic hot water. The controller has dual heating set points (heating and DHW) and can also control a three port diverting valve that directs the DHW to the cylinder. DHW production has priority irrespective of the mode of operation of the unit. The unit is normally used with two pipe water based change-over systems.

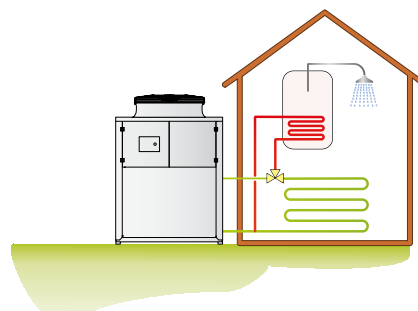

**OPERATION LIMITS**

(HA/HE versions)

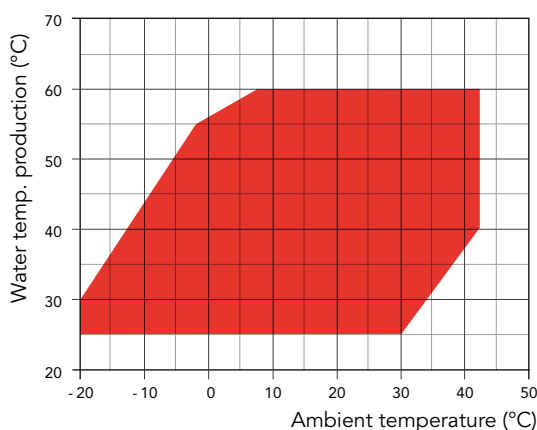

■ Heating mode

(RV versions Only)

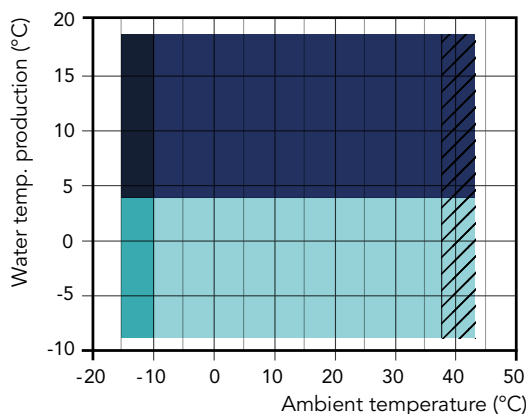

■ Cooling mode (only HE version)  
 ■ Cooling mode  
 ■ Cooling mode with glycol (only HE/BT version)  
 ■ Cooling mode with glycol (only BT version)  
 ▨ Possible noise increase for XL versions

## ACCESSORIES

LHE HA-HE /HH-RV	452	512	682	752	912	1102	1152	1352	1502	1612
Flow switch	●	●	●	●	●	●	●	●	●	●
Floating frame technology - LS version	-	-	-	-	-	-	-	-	-	-
Floating frame technology - XL version	●	●	●	●	●	●	●	●	●	●
Hydraulic kit with storage tank and one low-pressure pump	<b>A1LLU *</b>	◇	◇	◇	◇	◇	◇	◇	◇	◇
Hydraulic kit with one low-pressure pump	<b>A1LPU</b>	◇	◇	◇	◇	◇	◇	◇	◇	◇
Hydraulic kit with one pump without tank - user circuit	<b>A1NTU</b>	□	□	□	□	□	□	□	□	□
User circuit hydraulic kit, one inverter pump, no tank	<b>A1VSU</b>	○	○	○	○	○	○	○	○	○
User circuit hydraulic kit + inverter centrifugal pump	<b>A1VVU</b>	○	○	○	○	○	○	○	○	○
Integrated hydraulic kit 1 pump + Water tank	<b>A1ZZU *</b>	□	□	□	□	□	□	□	□	□
Hydraulic kit with two pumps without tank - user circuit	<b>A2NTU</b>	□	□	□	□	□	□	□	□	□
Integrated hydraulic kit 2 pumps + Water tank	<b>A2ZZU *</b>	□	□	□	□	□	□	□	□	□
Condensate discharge drip tray with antifreeze heater	<b>BRCA</b>	○	○	○	○	○	○	○	○	○
Low Temperature Operating	<b>BT</b>	○	○	○	○	○	○	○	○	○
4-connection tank and low-pressure pump	<b>BUF4A *</b>	◇	◇	◇	◇	◇	◇	◇	◇	◇
Fans regulation by phase cut (HA version)	<b>DCCF</b>	●	●	●	●	●	●	●	●	●
Refrigerant leakage detector	<b>DFR</b>	●	●	●	●	●	●	●	●	●
Electronic soft starter	<b>DSSE</b>	○	○	○	○	○	○	○	○	○
Double safety valve	<b>DSV</b>	○	○	○	○	○	○	○	○	○
Coil protection grid	<b>GBPE</b>	○	○	○	○	○	○	○	○	○
WIFI Application	<b>HIPRO.web</b>	○	○	○	○	○	○	○	○	○
Display	<b>HMI.PRO</b>	●	●	●	●	●	●	●	●	●
Serial interface card RS485	<b>INSE</b>	●	●	●	●	●	●	●	●	●
Rubber vibration dampers	<b>KAVG</b>	○	○	○	○	○	○	○	○	○
Spring vibration dampers	<b>KAVM</b>	○	○	○	○	○	○	○	○	○
COP internal optimizer kit	<b>KCOP</b>	○	○	○	○	○	○	○	○	○
Lifting rings kit	<b>KGS</b>	●	●	●	●	●	●	●	●	●
Safety valve ducting aid kit	<b>KCSV</b>	●	●	●	●	●	●	●	●	●
Double safety valve ducting aid kit	<b>KCDV</b>	○	○	○	○	○	○	○	○	○
Tank antifreeze kit	<b>KPSU</b>	○	○	○	○	○	○	○	○	○
User antifreeze kit	<b>KPU</b>	○	○	○	○	○	○	○	○	○
Victaulic kit	<b>KVICT</b>	-	-	-	-	-	-	-	-	-
Pressure gauges	<b>MAML</b>	○	○	○	○	○	○	○	○	○
Remote control panel	<b>PCRL</b>	○	○	○	○	○	○	○	○	○
Shut-off valve on compressor discharging side	<b>RDCO</b>	○	○	○	○	○	○	○	○	○
Cascade control system via RS485	<b>SGRS</b>	○	○	○	○	○	○	○	○	○
DHW probe kit	<b>SOND1</b>	●	●	●	●	●	●	●	●	●
E.C. fans - HA versions	<b>VECE</b>	-	-	-	-	-	-	-	-	-
E.C. fans - HE versions	<b>VECE</b>	●	●	●	●	●	●	●	●	●
Electronic expansion valve	<b>VTEE</b>	●	●	●	●	●	●	●	●	●

● Standard ○ Optional □ Optional only in the LS version ◇ Optional only in the XL version – Not available  
\* Excluding P2S version

LHE HA-HE /HH-RV	1792	2012	2304	2312	2654	2954	3214	3514	3954	4454
Flow switch	●	●	●	●	●	●	●	●	●	●
Floating frame technology - LS version	-	-	-	-	-	-	-	-	-	-
Floating frame technology - XL version	●	●	●	●	●	●	●	●	●	●
Hydraulic kit with storage tank and one low-pressure pump	<b>A1LLU *</b>	◇	◇	◇	◇	◇	◇	◇	◇	◇
Hydraulic kit with one low-pressure pump	<b>A1LPU</b>	◇	◇	◇	◇	◇	◇	◇	◇	◇
Hydraulic kit with one pump without tank - user circuit	<b>A1NTU</b>	□	□	□	□	□	□	□	□	□
User circuit hydraulic kit, one inverter pump, no tank	<b>A1VSU</b>	○	○	○	○	○	○	○	○	○
User circuit hydraulic kit + inverter centrifugal pump	<b>A1VVU</b>	○	○	○	○	○	○	○	○	○
Integrated hydraulic kit 1 pump + Water tank	<b>A1ZZU *</b>	□	□	□	□	□	□	□	□	□
Hydraulic kit with two pumps without tank - user circuit	<b>A2NTU</b>	□	□	□	□	□	□	□	□	□
Integrated hydraulic kit 2 pumps + Water tank	<b>A2ZZU *</b>	□	□	□	□	□	□	□	□	□
Condensate discharge drip tray with antifreeze heater	<b>BRCA</b>	○	○	○	○	○	○	○	○	○
Low Temperature Operating	<b>BT</b>	○	○	○	○	○	○	○	○	○
4-connection tank and low-pressure pump	<b>BUF4A *</b>	◇	◇	◇	◇	◇	◇	◇	◇	◇
Fans regulation by phase cut (HA version)	<b>DCCF</b>	●	●	●	●	●	●	●	●	●
Refrigerant leakage detector	<b>DFR</b>	●	●	●	●	●	●	●	●	●
Electronic soft starter	<b>DSSE</b>	○	○	○	○	○	○	○	○	○
Double safety valve	<b>DSV</b>	○	○	○	○	○	○	○	○	○
Coil protection grid	<b>GBPE</b>	○	○	○	○	○	○	○	○	○
WIFI Application	<b>HIPRO.web</b>	○	○	○	○	○	○	○	○	○
Display	<b>HMI.PRO</b>	●	●	●	●	●	●	●	●	●
Serial interface card RS485	<b>INSE</b>	●	●	●	●	●	●	●	●	●
Rubber vibration dampers	<b>KAVG</b>	○	○	○	○	○	○	○	○	○
Spring vibration dampers	<b>KAVM</b>	○	○	○	○	○	○	○	○	○
COP internal optimizer kit	<b>KCOP</b>	○	○	○	○	○	○	○	○	○
Lifting rings kit	<b>KGS</b>	●	●	●	●	●	●	●	●	●
Safety valve ducting aid kit	<b>KCSV</b>	●	●	●	●	●	●	●	●	●
Double safety valve ducting aid kit	<b>KCDV</b>	○	○	○	○	○	○	○	○	○
Tank antifreeze kit	<b>KPSU</b>	○	○	○	○	○	○	○	○	○
User antifreeze kit	<b>KPU</b>	○	○	○	○	○	○	○	○	○
Victaulic kit	<b>KVICT</b>	●	●	●	●	●	●	●	●	●
Pressure gauges	<b>MAML</b>	○	○	○	○	○	○	○	○	○
Remote control panel	<b>PCRL</b>	○	○	○	○	○	○	○	○	○
Shut-off valve on compressor discharging side	<b>RDCO</b>	○	○	○	○	○	○	○	○	○
Cascade control system via RS485	<b>SGRS</b>	○	○	○	○	○	○	○	○	○
DHW probe kit	<b>SOND1</b>	●	●	●	●	●	●	●	●	●
E.C. fans - HA versions	<b>VECE</b>	-	-	-	-	-	-	-	-	-
E.C. fans - HE versions	<b>VECE</b>	●	●	●	●	●	●	●	●	●
Electronic expansion valve	<b>VTEE</b>	●	●	●	●	●	●	●	●	●

● Standard ○ Optional □ Optional only in the LS version ◇ Optional only in the XL version - Not available  
\* Excluding P2S version

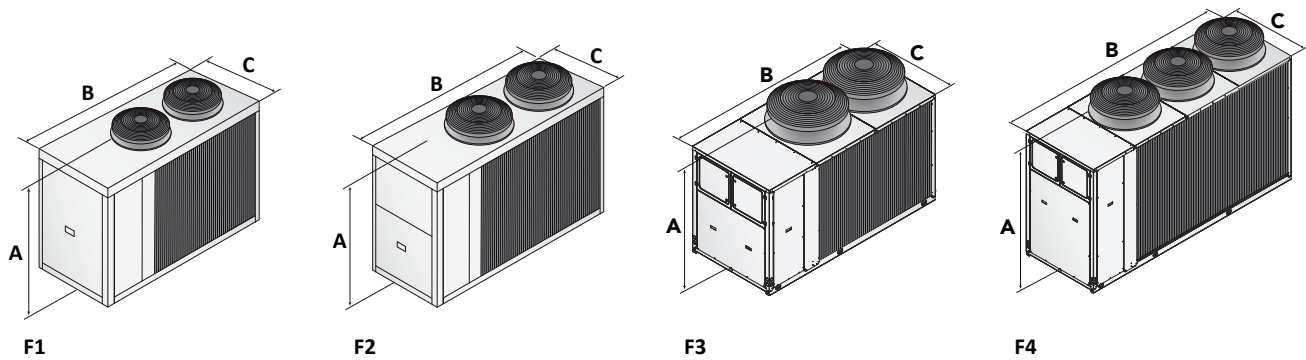

	452	512	682	752	912	1102	1152	1352	1502	1612
A (mm)	1838	1838	1955	1955	1955	1955	1955	1955	1955	1955
B (mm)	2400	2400	3000	3000	3000	3000	3000	4295	4295	4295
C (mm)	1265	1265	1265	1265	1265	1265	1265	1265	1265	1265
Kg	650	658	884	890	1100	1108	1110	1688	1714	1722
<b>FRAME</b>	<b>F1</b>	<b>F1</b>	<b>F2</b>	<b>F2</b>	<b>F3</b>	<b>F3</b>	<b>F3</b>	<b>F4</b>	<b>F4</b>	<b>F4</b>

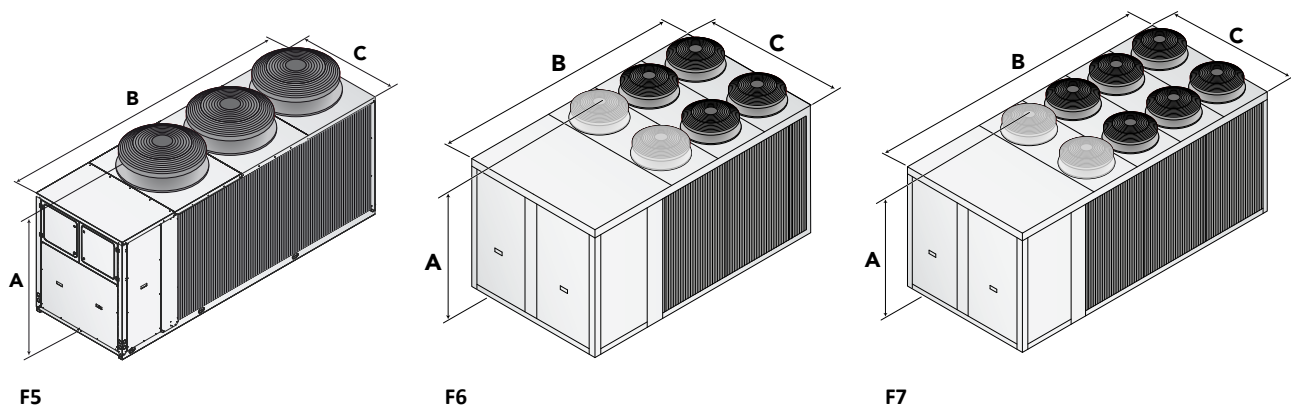

	1792	2012	2304	2312	2654	2954	3214	3514	3954	4454
A (mm)	1955	2355	2415	2355	2415	2415	2415	2415	2415	2415
B (mm)	4295	4296	4515	4296	4515	4515	4515	4515	5557	5557
C (mm)	1265	1265	2310	1265	2310	2310	2310	2310	2310	2310
Kg	1776	1762	1778	3262	3348	3438	3480	3508	3658	3686
<b>FRAME</b>	<b>F4</b>	<b>F5</b>	<b>F6</b>	<b>F5</b>	<b>F6</b>	<b>F6</b>	<b>F6</b>	<b>F6</b>	<b>F7</b>	<b>F7</b>

# PAE N

## HIGH EFFICIENCY AIR TO WATER HEAT PUMPS EQUIPPED WITH SCROLL COMPRESSOR AND AXIAL FANS WITH LOW GWP REFRIGERANT

Heating power from 78 kW to 1200 kW

R410A

R454B



Packaged air cooled heat pumps of PAE N Kc/Kr series are suitable for outdoor installation and can be used to cool and heat fluid solutions for air conditioning or in industrial applications. Multiscroll technology allows to reach great efficiency improvements at part load. All the units are totally factory assembled and tested, following specific quality procedures. Besides they are totally hydraulic, cooling and electrical connected permitting a quick installation once on site. Before the test the cooling circuits of each unit are subjected to a pressure test and then charged with Refrigerant R410A or R454B and non-freezing oil.

### VERSIONS

- RP** With partial heat recovery.
- HE** High efficiency, EC fans.
- U** Ultra low noise.

## TECHNICAL DATA

PAE N Kc		601	801	1001	1201	1401	1601	1801	1802	2002	2101	2302	2502	2802
Heating capacity (EN14511) <sup>(1)</sup>	kW	79,8	98,4	124,0	149,0	175,0	199,0	224,0	215,0	267,0	254,0	278,0	305,0	348,0
Total input power (EN14511) <sup>(1)</sup>	kW	19,5	24,8	30,8	37,0	44,2	49,6	54,6	57,4	72,8	62,4	69,5	78,5	91,9
Input current	A	41,1	48,4	60,2	69,2	82,6	91,3	99,6	112,0	121,0	114,0	131,0	145,0	169,0
COP (EN14511) <sup>(1)</sup>	W/W	4,09	3,97	4,03	4,03	3,96	4,01	4,10	3,75	3,67	4,07	4,00	3,89	3,79
SCOP	W/W	3,30	3,27	3,36	3,58	3,43	3,43	3,59	3,21	3,50	3,55	3,48	3,50	3,35
η <sub>s,h</sub> <sup>(2)</sup>	%	129	128	131	140	134	134	141	125	137	139	136	137	131
Cooling capacity (EN14511) <sup>(3)</sup>	kW	69,1	85,8	103,0	126,0	145,0	173,0	188,0	183,0	206,0	213,0	234,0	252,0	295,0
Total input power (EN14511) <sup>(3)</sup>	kW	22,7	30,4	35,9	44,1	50,8	59,6	66,4	63,3	67,5	72,1	77,2	86,6	103,0
Input current	A	44,4	55,6	65,8	77,5	90,0	104,0	115,0	118,0	122,0	126,0	138,0	153,0	182,0
EER	W/W	3,04	2,82	2,87	2,86	2,85	2,90	2,83	2,89	3,05	2,95	3,03	2,91	2,86
Sound power <sup>(4)</sup>	dB(A)	83	86	86	88	89	90	90	88	90	91	90	90	91
Sound pressure <sup>(5)</sup>	dB(A)	51	54	54	56	57	58	58	56	58	59	58	58	58
Power supply	V/ph/Hz	400/3/50												
Circuits	n°	1	1	1	1	1	1	1	2	2	1	1	1	1
Compressors	n°	2	2	2	2	2	2	2	4	4	2	2	2	2
Fans	n°	2	2	2	2	3	3	3	6	6	4	6	6	8
Refrigerant		R410A	R410A	R410A	R410A	R410A	R410A	R410A	R410A	R410A	R410A	R410A	R410A	R410A
Refrigerant charge	kg	23	22	33	45	50	50	66	62	94	66	94	94	88
Global warming potential	GWP	2088	2088	2088	2088	2088	2088	2088	2088	2088	2088	2088	2088	2088
Equivalent CO <sub>2</sub> charge	t	47	47	70	94	104	104	139	130	196	138	196	196	183
Frame		1	1	1	1	2	2	2	4	4	3	3	3	5
Transport weight	kg	977	1041	1117	1298	1432	1446	1725	1802	2066	1707	2018	2488	2641
Operating weight	kg	983	1047	1124	1305	1440	1455	1736	1814	2078	1719	2034	2505	2658

PAE N Kc		3202	3602	4202	4802	5202	5602	6002	7004	7504	8504	9504	10004	11004
Heating capacity (EN14511) <sup>(1)</sup>	kW	393,0	438,0	481,0	585,0	628,0	674,0	723,0	805,4	869,4	960,4	1092,8	1171,4	1256,6
Total input power (EN14511) <sup>(1)</sup>	kW	104,0	111,0	123,0	146,0	161,0	174,0	192,0	206,6	222,2	248,2	267,8	288,2	322,4
Input current	A	188,0	201,0	221,0	265,0	289,0	311,0	326,0	378,0	399,2	440,8	501,6	532,0	572,6
COP (EN14511) <sup>(1)</sup>	W/W	3,78	3,95	3,91	4,01	3,90	3,87	3,77	3,90	3,91	3,87	4,08	4,06	3,90
SCOP	W/W	3,48	3,56	3,60	3,61	3,52	3,42	3,41	-	-	-	-	-	-
η <sub>s,h</sub> <sup>(2)</sup>	%	136	139	141	141	138	134	-	-	-	-	-	-	-
Cooling capacity (EN14511) <sup>(3)</sup>	kW	336,0	382,0	427,0	497,0	555,0	600,0	646,0	701,1	765,6	852,4	951,2	1001,6	1114,0
Total input power (EN14511) <sup>(3)</sup>	kW	113,0	131,0	144,0	172,0	189,0	205,0	220,0	234,2	260,4	288,4	322,4	341,0	376,0
Input current	A	197,0	227,0	249,0	299,0	325,0	353,0	368,0	420,0	451,2	496,8	554,3	594,4	648,0
EER	W/W	2,97	2,92	2,97	2,89	2,94	2,93	2,94	2,99	2,94	2,96	2,95	2,94	2,96
Sound power <sup>(4)</sup>	dB(A)	90	92	94	92	94	94	96	93	93	96	95	95	96
Sound pressure <sup>(5)</sup>	dB(A)	58	59	62	60	62	62	63	60	60	63	62	62	63
Power supply	V/ph/Hz	400/3/50												
Circuits	n°	1	1	1	1	2	2	1	4	4	4	4	4	4
Compressors	n°	2	2	2	2	4	4	2	8	8	8	12	12	12
Fans	n°	8	8	8	10	10	12	12	16	16	16	20	20	20
Refrigerant		R410A	R410A	R410A	R410A	R410A	R410A	R410A	R410A	R410A	R410A	R410A	R410A	R410A
Refrigerant charge	kg	132	131	175	214	213	193	258	252	257	296	283	325	330
Global warming potential	GWP	2088	2088	2088	2088	2088	2088	2088	2088	2088	2088	2088	2088	2088
Equivalent CO <sub>2</sub> charge	t	276	274	365	446	446	402	538	525	536	619	591	678	689
Frame		5	5	5	6	6	7	7	9	9	9	10	10	10
Transport weight	kg	3101	3115	3578	4204	4230	4455	4964	7406	7480	7794	8690	9062	9153
Operating weight	kg	3120	3150	3613	4249	4280	4505	5023	7446	7530	7854	8750	9122	9243

Performances are referred to the following conditions:

(1) Heating: Ambient temperature 7°C DB, 6°C WB, water temperature 30/35°C.

(2) Average conditions, low temperature, variable - Reg EU 811/2013

(3) Cooling: ambient air temperature 35°C, evaporator water temperature in/out 12/7 °C

(4) Sound power level in accordance with ISO 3744.

(5) Sound pressure level at 10 mt from the unit in free field conditions in accordance with ISO 3744.

PAE N U Kc		601	801	1001	1201	1401	1601	1801	1802	2002	2101	2302	2502	2802
Heating capacity (EN14511) <sup>(1)</sup>	kW	78,8	102,0	123,0	154,0	178,0	203,0	227,0	221,0	245,0	252,0	281,0	296,0	349,0
Total input power (EN14511) <sup>(1)</sup>	kW	18,4	23,6	29,4	36,7	42,5	47,6	54,2	55,6	62,4	59,8	67,9	78,1	89,1
Input current	A	37,0	44,5	55,7	67,5	76,7	85,1	96,4	105,0	111,0	106,0	123,0	141,0	160,0
COP (EN14511) <sup>(1)</sup>	W/W	4,28	4,32	4,18	4,20	4,19	4,26	4,19	3,97	3,93	4,21	4,14	3,79	3,92
SCOP	W/W	3,63	3,69	3,68	3,67	3,74	3,74	3,73	3,53	3,65	3,76	3,76	3,48	3,68
η <sub>s,h</sub> <sup>(2)</sup>	%	142	145	144	144	147	147	146	138	143	147	147	136	144
Cooling capacity (EN14511) <sup>(3)</sup>	kW	67,8	84,4	101,0	125,0	147,0	170,0	187,0	185	202,0	209,0	231,0	251,0	294,0
Total input power (EN14511) <sup>(3)</sup>	kW	22,1	28,4	35,2	43,0	49,6	58,5	63,7	59,5	67,1	72,3	76,5	87,4	98,9
Input current	A	41,6	50,7	62,9	74,7	85,5	99,5	109,0	109,0	118,0	122,0	133,0	152,0	170,0
EER	W/W	3,07	2,97	2,87	2,91	2,96	2,91	2,94	3,11	3,01	2,89	3,02	2,87	2,97
Sound power <sup>(4)</sup>	dB(A)	80	82	82	84	85	86	86	83	84	87	84	84	85
Sound pressure <sup>(5)</sup>	dB(A)	49	50	50	51	53	53	53	50	52	55	52	52	52
Power supply	V/ph/Hz	400/3/50												
Circuits	n°	1	1	1	1	1	1	1	2	2	1	2	2	2
Compressors	n°	2	2	2	2	2	2	2	4	4	2	4	4	4
Fans	n°	2	2	2	3	3	3	4	6	6	4	6	8	8
Refrigerant		R410A	R410A	R410A	R410A	R410A	R410A	R410A	R410A	R410A	R410A	R410A	R410A	R410A
Refrigerant charge	kg	23	34	45	50	67	67	66	94	94	89	126	88	131
Global warming potential	GWP	2088	2088	2088	2088	2088	2088	2088	2088	2088	2088	2088	2088	2088
Equivalent CO <sub>2</sub> charge	t	47	70	93	105	140	140	138	196	196	186	263	183	274
Frame		1	1	1	2	2	2	3	4	4	3	3	5	5
Transport weight	kg	999	1075	1151	1327	1473	1486	1746	1824	2044	1793	2229	2503	2712
Operating weight	kg	1005	1082	1158	1334	1481	1496	1757	1836	2056	1805	2246	2520	2729

PAE N U Kc		3202	3602	4202	4802	5202	5602	6002	7004	7504	8504	9504	10004	11004
Heating capacity (EN14511) <sup>(1)</sup>	kW	389,0	433,0	496,0	579,0	622,0	670,0	720,0	780,0	857,2	986,0	1094,8	1152,0	1228,4
Total input power (EN14511) <sup>(1)</sup>	kW	102,0	108,0	123,0	145,0	159,0	169,0	176,0	196,0	216,4	246,2	273,7	288,4	318,6
Input current	A	178,0	191,0	215,0	257,0	280,0	296,0	305,0	352,0	380,0	440,8	501,6	515,0	550,8
COP (EN14511) <sup>(1)</sup>	W/W	3,81	4,01	4,03	3,99	3,91	3,96	4,09	3,98	3,96	4,00	4,00	3,99	3,86
SCOP	W/W	3,69	3,76	3,65	3,68	3,61	4,46	3,86	-	-	-	-	-	-
η <sub>s,h</sub> <sup>(2)</sup>	%	145	147	143	144	141	175	-	-	-	-	-	-	-
Cooling capacity (EN14511) <sup>(3)</sup>	kW	328,0	383,0	432,0	508,0	559,0	604,0	637,0	700,0	760,0	865,0	953,0	1011,0	1127,2
Total input power (EN14511) <sup>(3)</sup>	kW	113,0	129,0	145,0	171,0	191,0	206,0	216,0	234,9	258,2	289,6	323,1	343,4	379,4
Input current	A	193,0	219,0	246,0	292,0	324,0	347,0	363,0	407,0	440,4	491,2	554,3	587,2	646,8
EER	W/W	2,90	2,97	2,98	2,97	2,93	2,93	2,95	2,98	2,94	2,99	2,95	2,94	2,97
Sound power <sup>(4)</sup>	dB(A)	84	86	88	86	88	88	90	89	90	93	94	91	93
Sound pressure <sup>(5)</sup>	dB(A)	52	53	56	53	56	56	57	55	56	60	61	57	60
Power supply	V/ph/Hz	400/3/50												
Circuits	n°	2	2	2	2	2	2	2	4	4	4	4	4	4
Compressors	n°	4	4	4	6	6	6	6	8	8	8	12	12	12
Fans	n°	8	8	10	12	12	12	14	16	16	20	24	24	24
Refrigerant		R410A	R410A	R410A	R410A	R410A	R410A	R410A	R410A	R410A	R410A	R410A	R410A	R410A
Refrigerant charge	kg	176	175	159	194	193	259	229	253	292	320	395	468	473
Global warming potential	GWP	2088	2088	2088	2088	2088	2088	2088	2088	2088	2088	2088	2088	2088
Equivalent CO <sub>2</sub> charge	t	367	365	332	405	402	541	479	529	609	668	825	977	987
Frame		5	5	6	7	7	7	8	9	9	10	11	11	11
Transport weight	kg	3171	3185	3582	4204	4230	4550	4955	7057	7406	8398	9162	9775	9842
Operating weight	kg	3190	3220	3617	4250	4279	4600	5014	7097	7456	8458	9222	9845	9932

Performances are referred to the following conditions:

(1) Heating: Ambient temperature 7°C DB, 6°C WB, water temperature 30/35°C.

(2) Average conditions, low temperature, variable - Reg EU 811/2013

(3) Cooling: ambient air temperature 35°C, evaporator water temperature in/out 12/7 °C

(4) Sound power level in accordance with ISO 3744.

(5) Sound pressure level at 10 mt from the unit in free field conditions in accordance with ISO 3744.

PAE N HE Kc		1001	1201	1401	1601	1802	2002	2302	2502	2802	3202	3602
Heating capacity (EN14511) <sup>(1)</sup>	kW	131,0	161,0	186,0	214,0	227,0	257,0	287,0	317,0	357,0	400,0	460,0
Total input power (EN14511) <sup>(1)</sup>	kW	30,6	35,5	43,1	49,2	54,5	60,5	68,4	78,6	89,8	102,0	114,0
Input current	A	57,0	65,9	76,4	86,3	101,0	108,0	122,0	139,0	157,0	177,0	197,0
COP (EN14511) <sup>(1)</sup>	W/W	4,28	4,41	4,32	4,35	4,17	4,25	4,20	4,03	3,98	3,92	4,04
SCOP	W/W	3,32	3,76	3,53	3,56	3,45	3,69	3,69	3,63	3,62	3,77	3,62
η <sub>s,h</sub> <sup>(2)</sup>	%	130	147	138	139	135	145	145	142	142	148	142
Cooling capacity (EN14511) <sup>(3)</sup>	kW	107,0	133,0	153,0	181,0	193,0	215,0	235,0	268,0	304,0	342,0	383,0
Total input power (EN14511) <sup>(3)</sup>	kW	35,7	43,2	50,3	58,1	62,9	68,6	77,7	86,7	101,0	114,0	130,0
Input current	A	63,5	74,4	85,9	98,2	113,0	119,0	134,0	150,0	172,0	193,0	220,0
EER	W/W	3,00	3,08	3,04	3,12	3,07	3,13	3,02	3,09	3,01	3,00	2,95
Sound power <sup>(4)</sup>	dB(A)	84	87	87	88	89	91	91	91	91	91	92
Sound pressure <sup>(5)</sup>	dB(A)	52	55	55	56	57	58	58	59	59	58	60
Power supply	V/ph/Hz	400/3/50										
Circuits	n°	1	1	1	1	2	2	2	2	2	2	2
Compressors	n°	2	2	2	2	4	4	4	4	4	4	4
Fans	n°	3	3	4	4	6	6	6	8	8	8	10
Refrigerant		R410A	R410A	R410A	R410A	R410A	R410A	R410A	R410A	R410A	R410A	R410A
Refrigerant charge	kg	50	67	66	89	94	126	126	132	131	176	161
Global warming potential	GWP	2088	2088	2088	2088	2088	2088	2088	2088	2088	2088	2088
Equivalent CO <sub>2</sub> charge	t	104	140	138	186	196	263	263	276	274	367	335
Frame		2	2	3	3	4	4	4	5	5	5	6
Transport weight	kg	1325	1452	1644	1787	2185	2431	2431	2852	3034	3482	3610
Operating weight	kg	1334	1463	1655	1804	2202	2447	2447	2871	3056	3506	3645

PAE N HE Kc		4202	4802	5202	5602	6002	7004	7504	8504	9504	10004	
Heating capacity (EN14511) <sup>(1)</sup>	kW	516,0	625,0	674,0	693,0	734,0	808,8	920,0	1032,2	1098,3	1200,0	
Total input power (EN14511) <sup>(1)</sup>	kW	126,0	128,0	140,0	177,0	191,0	203,2	228,0	252,0	274,6	302,0	
Input current	A	217,0	262,0	285,0	305,0	326,0	350,0	392,0	432,0	501,6	518,2	
COP (EN14511) <sup>(1)</sup>	W/W	4,10	4,88	4,81	3,92	3,84	3,98	4,04	4,10	4,00	3,97	
SCOP	W/W	3,82	3,58	3,52	3,21	3,30	-	-	-	-	-	
η <sub>s,h</sub> <sup>(2)</sup>	%	150	140	138	-	-	-	-	-	-	-	
Cooling capacity (EN14511) <sup>(3)</sup>	kW	435,0	517,0	565,0	612,0	650,0	704,0	762,0	867,6	956,0	1033,6	
Total input power (EN14511) <sup>(3)</sup>	kW	145,0	171,0	188,0	202,0	218,0	234,7	260,0	289,0	312,4	341,4	
Input current	A	243,0	289,0	317,0	339,0	365,0	396,0	439,2	486,2	554,3	575,6	
EER	W/W	3,00	3,02	3,01	3,03	2,98	3,00	2,93	3,00	3,06	3,03	
Sound power <sup>(4)</sup>	dB(A)	94	92	95	95	96	95	96	97	95	96	
Sound pressure <sup>(5)</sup>	dB(A)	62	60	62	62	63	62	63	64	62	63	
Power supply	V/ph/Hz	400/3/50										
Circuits	n°	2	2	2	2	2	4	4	4	4	4	
Compressors	n°	4	6	6	6	6	8	8	8	12	12	
Fans	n°	10	12	14	14	14	16	20	20	24	24	
Refrigerant		R410A	R410A	R410A	R410A	R410A	R410A	R410A	R410A	R410A	R410A	
Refrigerant charge	kg	214	259	229	308	308	293	280	321	397	470	
Global warming potential	GWP	2088	2088	2088	2088	2088	2088	2088	2088	2088	2088	
Equivalent CO <sub>2</sub> charge	t	446	541	479	643	643	611	584	671	828	981	
Frame		6	7	8	8	8	9	10	10	11	11	
Transport weight	kg	3955	4597	4697	5190	5220	7316	7698	8314	9081	9690	
Operating weight	kg	3995	4646	4756	5248	5279	7360	7749	8364	9747	9133	

Performances are referred to the following conditions:

(1) Heating: Ambient temperature 7°C DB, 6°C WB, water temperature 30/35°C.

(2) Average conditions, low temperature, variable - Reg EU 811/2013

(3) Cooling: ambient air temperature 35°C, evaporator water temperature in/out 12/7 °C

(4) Sound power level in accordance with ISO 3744.

(5) Sound pressure level at 10 mt from the unit in free field conditions in accordance with ISO 3744.

PAE N HE U Kc		1001	1201	1401	1601	1802	2002	2302	2502	2802	3202	3602
Heating capacity (EN14511) <sup>(1)</sup>	kW	130,0	156,0	181,0	207,0	219,0	248,0	276,0	307,0	344,0	384,0	444,0
Total input power (EN14511) <sup>(1)</sup>	kW	28,4	34,1	40,1	45,8	50,4	56,4	64,9	72,3	83,8	94,8	105,0
Input current	A	53,6	62,4	72,1	81,5	95,1	102,0	116,0	130,0	148,0	166,0	184,0
COP (EN14511) <sup>(1)</sup>	W/W	4,58	4,57	4,51	4,52	4,35	4,40	4,25	4,25	4,11	4,05	4,23
SCOP	W/W	3,88	4,17	4,08	4,05	3,94	4,11	4,07	3,97	4,11	4,05	3,99
$\eta_{s,h}$ <sup>(2)</sup>	%	152	164	160	159	155	161	160	156	161	159	157
Cooling capacity (EN14511) <sup>(3)</sup>	kW	107,0	131,0	153,0	181,0	192,0	213,0	231,0	264,0	300,0	335,0	377,0
Total input power (EN14511) <sup>(3)</sup>	kW	32,9	40,7	46,5	54,3	57,9	64,4	73,9	81,1	95,2	110,0	124,0
Input current	A	59,7	71,1	80,9	93,2	106,0	113,0	129,0	142,0	164,0	187,0	211,0
EER	W/W	3,25	3,22	3,29	3,33	3,32	3,31	3,13	3,26	3,15	3,05	3,04
Sound power <sup>(4)</sup>	dB(A)	80	82	82	83	82	84	84	84	85	84	86
Sound pressure <sup>(5)</sup>	dB(A)	48	49	50	50	49	52	52	52	52	52	53
Power supply	V/ph/Hz	400/3/50										
Circuits	n°	1	1	1	1	2	2	2	2	2	2	2
Compressors	n°	2	2	2	2	4	4	4	4	4	4	4
Fans	n°	3	3	4	4	6	6	6	8	8	8	10
Refrigerant		R410A	R410A	R410A	R410A	R410A	R410A	R410A	R410A	R410A	R410A	R410A
Refrigerant charge	kg	50	67	66	89	94	126	126	132	131	176	161
Global warming potential	GWP	2088	2088	2088	2088	2088	2088	2088	2088	2088	2088	2088
Equivalent CO <sub>2</sub> charge	t	104	140	138	186	196	263	263	276	274	367	335
Frame		2	2	3	3	4	4	4	5	5	5	6
Transport weight	kg	1347	1474	1666	1809	2207	2453	2453	2874	3056	3504	3632
Operating weight	kg	1356	1485	1677	1826	2224	2469	2469	2893	3078	3528	3667

PAE N HE U Kc		4202	4802	5202	5602	6002	7004	7504	8504	9504	10004	
Heating capacity (EN14511) <sup>(1)</sup>	kW	497,0	575,0	621,0	664,0	703,0	806,5	905,6	1011,8	1091,4	1175,8	
Total input power (EN14511) <sup>(1)</sup>	kW	118,0	140,0	151,0	167,0	175,0	194,8	210,0	236,0	260,1	280,2	
Input current	A	204,0	246,0	266,0	289,0	304,0	340,0	366,0	405,6	501,6	486,8	
COP (EN14511) <sup>(1)</sup>	W/W	4,21	4,11	4,09	3,98	4,02	4,14	4,31	4,29	4,20	4,20	
SCOP	W/W	4,08	3,96	3,95	3,82	3,87	-	-	-	-	-	
$\eta_{s,h}$ <sup>(2)</sup>	%	160	155	155	-	-	-	-	-	-	-	
Cooling capacity (EN14511) <sup>(3)</sup>	kW	427,0	508,0	555,0	596,0	635,0	702,0	754,0	853,8	950,0	1011,0	
Total input power (EN14511) <sup>(3)</sup>	kW	140,0	164,0	180,0	196,0	213,0	227,9	247,8	279,6	310,5	330,4	
Input current	A	236,0	279,0	306,0	331,0	357,0	389,0	423,2	472,4	554,3	563,0	
EER	W/W	3,05	3,10	3,08	3,04	2,98	3,08	3,04	3,05	3,06	3,06	
Sound power <sup>(4)</sup>	dB(A)	88	86	88	88	92	89	90	93	91	91	
Sound pressure <sup>(5)</sup>	dB(A)	56	54	56	56	60	56	57	60	58	58	
Power supply	V/ph/Hz	400/3/50										
Circuits	n°	2	2	2	2	2	4	4	4	4	4	
Compressors	n°	4	6	6	6	6	8	8	8	12	12	
Fans	n°	10	12	14	14	14	16	20	20	24	24	
Refrigerant		R410A	R410A	R410A	R410A	R410A	R410A	R410A	R410A	R410A	R410A	
Refrigerant charge	kg	214	259	229	308	308	292	279	320	395	468	
Global warming potential	GWP	2088	2088	2088	2088	2088	2088	2088	2088	2088	2088	
Equivalent CO <sub>2</sub> charge	t	446	541	479	643	643	610	582	669	826	978	
Frame		6	7	8	8	8	9	10	10	11	11	
Transport weight	kg	3977	4619	4719	5212	5242	7421	7804	8418	9180	9795	
Operating weight	kg	4017	4668	4778	5270	5301	7465	7855	8468	9232	9851	

Performances are referred to the following conditions:

(1) Heating: Ambient temperature 7°C DB, 6°C WB, water temperature 30/35°C.

(2) Average conditions, low temperature, variable - Reg EU 811/2013

(3) Cooling: ambient air temperature 35°C, evaporator water temperature in/out 12/7 °C

(4) Sound power level in accordance with ISO 3744.

(5) Sound pressure level at 10 mt from the unit in free field conditions in accordance with ISO 3744.

PAE N Kr		601	801	1001	1201	1401	1601	1801	1802	2002	2101	2302	2502	2802
Heating capacity (EN14511) <sup>(1)</sup>	kW	73,1	89,7	119,0	146,0	169,0	191,0	214,0	212,0	251,0	244,0	274,0	298,0	323,0
Total input power (EN14511) <sup>(1)</sup>	kW	19,3	23,5	30,1	36,9	42,3	48,2	53,4	56,1	64,8	60,4	69,8	75,6	87,2
Input current	A	40,4	48,8	59,6	70,4	79,7	92,4	98,2	108,0	120,0	115,0	131,0	142,0	158,0
COP (EN14511) <sup>(1)</sup>	W/W	3,79	3,82	3,95	3,96	4,00	3,96	4,01	3,78	3,87	4,04	3,93	3,94	3,70
SCOP	W/W	3,22	3,35	3,33	3,48	3,56	3,50	3,62	3,20	3,31	3,58	3,60	3,72	3,53
η <sub>s,h</sub> <sup>(2)</sup>	%	126	131	130	136	139	137	142	125	130	140	141	146	138
Cooling capacity (EN14511) <sup>(3)</sup>	kW	62,2	77,3	103,0	126,0	149,0	169,0	186,0	181,0	210,0	215,0	233,0	253,0	288,0
Total input power (EN14511) <sup>(3)</sup>	kW	21,5	27,4	35,0	43,7	49,6	57,2	62,5	64,1	70,3	68,3	77,8	85,8	99,9
Input current	A	42,2	52,8	64,4	77,4	87,1	102,0	109,0	116,0	124,0	123,0	138,0	152,0	172,0
EER	W/W	2,89	2,82	2,94	2,88	3,00	2,95	2,98	2,82	2,99	3,15	2,99	2,95	2,88
Sound power <sup>(4)</sup>	dB(A)	83	86	86	88	89	90	90	88	90	91	90	90	91
Sound pressure <sup>(5)</sup>	dB(A)	51	54	54	56	57	58	58	56	58	59	58	58	58
Power supply	V/ph/Hz	400/3/50												
Circuits	n°	1	1	1	1	1	1	1	2	2	1	2	2	2
Compressors	n°	2	2	2	2	2	2	2	4	4	2	4	4	4
Fans	n°	2	2	2	2	3	3	3	6	6	4	6	6	8
Refrigerant		R454B	R454B	R454B	R454B	R454B	R454B	R454B	R454B	R454B	R454B	R454B	R454B	R454B
Refrigerant charge	kg	22	22	34	45	51	50	67	95	94	31	95	95	88
Global warming potential	GWP	466	466	466	466	466	466	466	466	466	466	466	466	466
Equivalent CO <sub>2</sub> charge	t	10	10	16	21	24	23	31	44	44	14	44	44	41
Frame		1	1	1	1	2	2	2	4	4	3	4	4	5
Transport weight	kg	977	1041	1117	1298	1432	1446	1725	1802	2066	1701	2018	2488	2641
Operating weight	kg	983	1047	1124	1305	1440	1455	1736	1814	2078	1719	2034	2505	2658

PAE N Kr		3202	3602	4202	4802	5202	5602	6002	7004	7504	8504	9504	10004	11004
Heating capacity (EN14511) <sup>(1)</sup>	kW	376,0	422,0	470,0	562,0	606,0	646,0	702,0	782,0	844,1	932,4	1060,9	1137,3	1220,0
Total input power (EN14511) <sup>(1)</sup>	kW	97,6	108,0	116,0	140,0	150,0	165,0	177,0	201,5	214,4	239,8	266,6	285,0	310,1
Input current	A	170,0	193,0	215,0	245,0	268,0	298,0	315,0	368,6	385,1	425,8	499,2	526,0	550,7
COP (EN14511) <sup>(1)</sup>	W/W	3,85	3,91	4,05	4,01	4,04	3,92	3,97	3,88	3,94	3,89	3,98	3,99	3,93
SCOP	W/W	3,66	3,76	3,91	3,73	3,79	3,62	3,50	-	-	-	-	-	-
η <sub>s,h</sub> <sup>(2)</sup>	%	143	147	154	146	149	142	-	-	-	-	-	-	-
Cooling capacity (EN14511) <sup>(3)</sup>	kW	324,0	372,0	413,0	487,0	527,0	569,0	633,0	680,7	743,3	827,6	923,5	972,4	1081,6
Total input power (EN14511) <sup>(3)</sup>	kW	108,0	123,0	136,0	162,0	177,0	193,0	207,0	219,0	244,7	271,1	305,1	321,3	352,8
Input current	A	182,0	212,0	239,0	271,0	302,0	334,0	355,0	392,6	424,0	467,0	524,5	560,0	608,0
EER	W/W	3,00	3,02	3,04	3,01	2,98	2,95	4,12	3,11	3,04	3,05	3,03	3,03	3,07
Sound power <sup>(4)</sup>	dB(A)	90	92	94	92	94	94	96	95	95	97	98	98	98
Sound pressure <sup>(5)</sup>	dB(A)	58	59	62	60	62	62	63	62	62	65	65	65	65
Power supply	V/ph/Hz	400/3/50												
Circuits	n°	2	2	2	2	2	2	2	4	4	4	4	4	4
Compressors	n°	4	4	4	6	6	6	6	8	8	8	12	12	12
Fans	n°	8	8	8	10	10	12	12	16	16	16	20	20	20
Refrigerant		R454B	R454B	R454B	R454B	R454B	R454B	R454B	R454B	R454B	R454B	R454B	R454B	R454B
Refrigerant charge	kg	133	131	175	214	213	193	258	248	253	292	279	320	325
Global warming potential	GWP	466	466	466	466	466	466	466	466	466	466	466	466	466
Equivalent CO <sub>2</sub> charge	t	62	61	81	100	99	90	120	116	118	136	130	149	151
Frame		5	5	5	6	6	7	7	9	9	9	10	10	10
Transport weight	kg	3101	3115	3578	4204	4230	4455	4964	7535	7610	7930	8841	9220	9312
Operating weight	kg	3120	3150	3613	4249	4280	4505	5023	7575	7660	7990	8901	9280	9402

Performances are referred to the following conditions:

(1) Heating: Ambient temperature 7°C DB, 6°C WB, water temperature 30/35°C.

(2) Average conditions, low temperature, variable - Reg EU 811/2013

(3) Cooling: ambient air temperature 35°C, evaporator water temperature in/out 12/7 °C

(4) Sound power level in accordance with ISO 3744.

(5) Sound pressure level at 10 mt from the unit in free field conditions in accordance with ISO 3744.

PAE N U Kr		601	801	1001	1201	1401	1601	1801	1802	2002	2101	2302	2502	2802
Heating capacity (EN14511) <sup>(1)</sup>	kW	72,6	89,8	120,0	147,0	170,0	191,0	215,0	214,0	249,0	244,0	274,0	295,0	326,0
Total input power (EN14511) <sup>(1)</sup>	kW	18,3	22,7	29,6	36,6	40,5	46,4	52,5	53,4	61,9	57,4	67,0	76,6	83,9
Input current	A	36,4	45,3	56,1	68,7	73,6	86,4	94,4	101,0	111,0	106,0	123,0	138,0	148,0
COP (EN14511) <sup>(1)</sup>	W/W	3,97	3,96	4,05	4,02	4,20	4,12	4,10	4,01	4,02	4,24	4,09	3,95	3,89
SCOP	W/W	3,50	3,76	3,86	3,77	3,97	3,96	3,87	3,84	3,86	4,00	3,96	3,77	3,94
η <sub>s,h</sub> <sup>(2)</sup>	%	137	147	151	148	156	155	152	151	151	157	156	148	155
Cooling capacity (EN14511) <sup>(3)</sup>	kW	62,2	77,3	104,0	126,0	150,0	169,0	186,0	181,0	210,0	214,0	233,0	253,0	288,0
Total input power (EN14511) <sup>(3)</sup>	kW	20,8	25,6	33,9	42,5	48,2	56,2	59,9	59,8	70,5	67,3	77,8	85,8	99,9
Input current	A	38,9	48,4	60,8	74,6	82,3	97,9	103,0	108,0	121,0	118,0	138,0	152,0	172,0
EER	W/W	2,99	3,02	3,07	2,96	3,11	3,01	3,11	3,03	2,98	3,18	2,99	2,95	2,88
Sound power <sup>(4)</sup>	dB(A)	80	82	82	84	85	86	86	83	84	87	84	84	85
Sound pressure <sup>(5)</sup>	dB(A)	49	50	50	51	53	53	53	50	52	55	52	52	52
Power supply	V/ph/Hz	400/3/50												
Circuits	n°	1	1	1	1	1	1	1	2	2	1	2	2	2
Compressors	n°	2	2	2	2	2	2	2	4	4	2	4	4	4
Fans	n°	2	2	2	3	3	3	4	6	6	4	6	8	8
Refrigerant		R454B	R454B	R454B	R454B	R454B	R454B	R454B	R454B	R454B	R454B	R454B	R454B	R454B
Refrigerant charge	kg	22	34	45	51	68	67	67	95	95	89	126	89	132
Global warming potential	GWP	466	466	466	466	466	466	466	466	466	466	466	466	466
Equivalent CO <sub>2</sub> charge	t	10	16	21	24	32	31	31	44	44	42	59	41	62
Frame		1	1	1	2	2	2	3	4	4	3	4	5	5
Transport weight	kg	999	1075	1151	1327	1473	1486	1746	1824	2044	1793	2229	2503	2712
Operating weight	kg	1005	1082	1158	1334	1481	1496	1757	1836	2056	1805	2246	2520	2729

PAE N U Kr		3202	3602	4202	4802	5202	5602	6002	7004	7504	8504	9504	10004	11004
Heating capacity (EN14511) <sup>(1)</sup>	kW	378,0	419,0	465,0	560,0	600,0	633,0	706,0	757,3	832,2	957,3	1062,9	1118,4	1192,6
Total input power (EN14511) <sup>(1)</sup>	kW	95,0	104,0	115,0	137,0	148,0	158,0	179,0	184,6	203,1	232,0	259,7	273,6	293,7
Input current	A	161,0	183,0	209,0	234,0	258,0	282,0	319,0	331,6	356,6	415,3	475,9	488,5	507,7
COP (EN14511) <sup>(1)</sup>	W/W	3,98	4,03	4,04	4,09	4,05	4,01	3,94	4,10	4,10	4,13	4,09	4,09	4,06
SCOP	W/W	3,96	4,05	4,04	3,93	3,99	3,97	3,39	-	-	-	-	-	-
η <sub>s,h</sub> <sup>(2)</sup>	%	155	159	159	154	157	156	-	-	-	-	-	-	-
Cooling capacity (EN14511) <sup>(3)</sup>	kW	324,0	372,0	413,0	487,0	527,0	569,0	853,0	676,3	734,3	835,7	920,8	976,8	1089,1
Total input power (EN14511) <sup>(3)</sup>	kW	108,0	123,0	136,0	162,0	177,0	193,0	207,0	226,2	246,2	274,9	307,1	326,2	361,7
Input current	A	182,0	212,0	239,0	271,0	302,0	334,0	355,0	391,9	419,9	466,3	526,9	557,7	616,6
EER	W/W	3,00	3,02	3,04	3,01	2,98	2,95	4,12	2,99	2,98	3,04	3,00	2,99	3,01
Sound power <sup>(4)</sup>	dB(A)	84	86	88	86	88	88	90	91	92	95	97	94	96
Sound pressure <sup>(5)</sup>	dB(A)	52	53	56	53	56	56	57	57	58	62	64	60	63
Power supply	V/ph/Hz	400/3/50												
Circuits	n°	2	2	2	2	2	2	2	4	4	4	4	4	4
Compressors	n°	4	4	4	6	6	6	6	8	8	12	12	12	12
Fans	n°	8	8	10	12	12	12	14	16	16	20	24	24	24
Refrigerant		R454B	R454B	R454B	R454B	R454B	R454B	R454B	R454B	R454B	R454B	R454B	R454B	R454B
Refrigerant charge	kg	176	175	159	194	193	259	229	250	288	316	390	462	467
Global warming potential	GWP	466	466	466	466	466	466	466	466	466	466	466	466	466
Equivalent CO <sub>2</sub> charge	t	82	81	74	90	90	121	107	117	134	147	182	215	217
Frame		5	5	6	7	7	7	8	9	9	10	11	11	11
Transport weight	kg	3171	3185	3582	4204	4230	4550	4955	7180	7535	8544	9321	9945	10013
Operating weight	kg	3190	3220	3617	4250	4279	4600	5014	7220	7585	8604	9381	10015	10103

Performances are referred to the following conditions:

(1) Heating: Ambient temperature 7°C DB, 6°C WB, water temperature 30/35°C.

(2) Average conditions, low temperature, variable - Reg EU 811/2013

(3) Cooling: ambient air temperature 35°C, evaporator water temperature in/out 12/7 °C

(4) Sound power level in accordance with ISO 3744.

(5) Sound pressure level at 10 mt from the unit in free field conditions in accordance with ISO 3744.

PAE N HE Kr		1001	1201	1401	1601	1802	2002	2302	2502	2802	3202	3602
Heating capacity (EN14511) <sup>(1)</sup>	kW	124,0	154,0	175,0	203,0	220,0	253,0	277,0	305,0	339,0	376,0	433,0
Total input power (EN14511) <sup>(1)</sup>	kW	30,5	37,4	42,3	48,1	54,4	62,2	69,1	76,0	86,0	96,1	106,0
Input current	A	56,7	67,6	74,4	87,1	101,0	110,0	123,0	138,0	149,0	160,0	185,0
COP (EN14511) <sup>(1)</sup>	W/W	4,07	4,12	4,14	4,22	4,04	4,07	4,01	4,01	3,94	3,91	4,08
SCOP	W/W	3,26	3,63	3,45	3,51	3,45	3,59	3,63	3,61	3,64	3,70	3,66
$\eta_{s,h}$ <sup>(2)</sup>	%	127	142	135	137	135	141	142	141	142	145	143
Cooling capacity (EN14511) <sup>(3)</sup>	kW	104,0	128,0	150,0	174,0	185,0	209,0	229,0	261,0	291,0	321,0	366,0
Total input power (EN14511) <sup>(3)</sup>	kW	33,1	41,5	46,5	52,3	59,7	68,9	76,7	81,9	94,8	107,0	121,0
Input current	A	59,8	72,6	79,6	92,2	107,0	119,0	133,0	145,0	161,0	176,0	206,0
EER	W/W	3,14	3,08	3,23	3,33	3,10	3,03	2,99	3,19	3,07	3,00	3,02
Sound power <sup>(4)</sup>	dB(A)	84	87	87	88	89	91	91	91	91	91	92
Sound pressure <sup>(5)</sup>	dB(A)	52	55	55	56	57	58	52	59	59	58	60
Power supply	V/ph/Hz	400/3/50										
Circuits	n°	1	1	1	1	2	2	2	2	2	2	2
Compressors	n°	2	2	2	2	4	4	4	4	4	4	4
Fans	n°	3	3	4	4	6	6	6	8	8	8	10
Refrigerant		R454B	R454B	R454B	R454B	R454B	R454B	R454B	R454B	R454B	R454B	R454B
Refrigerant charge	kg	51	67	67	89	95	126	126	132	132	176	161
Global warming potential	GWP	466	466	466	466	466	466	466	466	466	466	466
Equivalent CO <sub>2</sub> charge	t	24	31	31	41	44	59	59	62	62	82	75
Frame		2	2	3	3	4	4	4	5	5	5	6
Transport weight	kg	1325	1452	1644	1787	2185	2431	2431	2852	3034	3482	3610
Operating weight	kg	1334	1463	1655	1804	2202	2447	2447	2871	3056	3506	3645

PAE N HE Kr		4202	4802	5202	5602	6002	7004	7504	8504	9504	10004	
Heating capacity (EN14511) <sup>(1)</sup>	kW	488,0	563,0	609,0	665,0	708,0	785,2	893,2	1002,1	1066,3	1165,0	
Total input power (EN14511) <sup>(1)</sup>	kW	117,0	141,0	153,0	166,0	178,0	202,0	226,7	248,5	271,6	294,2	
Input current	A	210,0	237,0	264,0	291,0	317,0	347,9	389,8	426,1	496,1	504,8	
COP (EN14511) <sup>(1)</sup>	W/W	4,17	3,99	3,98	4,01	3,98	3,89	3,94	4,03	3,93	3,96	
SCOP	W/W	3,92	3,59	3,25	3,29	3,38	-	-	-	-	-	
$\eta_{s,h}$ <sup>(2)</sup>	%	154	141	-	-	-	-	-	-	-	-	
Cooling capacity (EN14511) <sup>(3)</sup>	kW	418,0	483,0	531,0	576,0	620,0	683,5	739,8	842,3	928,2	1003,5	
Total input power (EN14511) <sup>(3)</sup>	kW	134,0	159,0	175,0	187,0	200,0	220,6	247,2	274,9	300,0	322,1	
Input current	A	232,0	262,0	294,0	320,0	346,0	372,3	417,6	462,5	532,3	543,1	
EER	W/W	3,12	3,04	3,03	3,08	3,10	3,10	2,99	3,06	3,09	3,12	
Sound power <sup>(4)</sup>	dB(A)	94	92	95	95	96	97	98	99	98	99	
Sound pressure <sup>(5)</sup>	dB(A)	62	60	62	62	63	64	65	66	65	66	
Power supply	V/ph/Hz	400/3/50										
Circuits	n°	2	2	2	2	2	4	4	4	4	4	
Compressors	n°	4	6	6	6	6	8	8	8	12	12	
Fans	n°	10	12	14	14	14	16	20	20	24	24	
Refrigerant		R454B	R454B	R454B	R454B	R454B	R454B	R454B	R454B	R454B	R454B	
Refrigerant charge	kg	214	259	229	308	308	288	275	316	390	462	
Global warming potential	GWP	466	466	466	466	466	466	466	466	466	466	
Equivalent CO <sub>2</sub> charge	t	100	121	107	144	144	134	128	147	182	215	
Frame		6	7	8	8	8	9	10	10	11	11	
Transport weight	kg	3955	4597	4697	5190	5220	7550	7940	8564	9340	9965	
Operating weight	kg	3995	4646	4756	5248	5279	7594	7990	8614	9391	10021	

Performances are referred to the following conditions:

(1) Heating: Ambient temperature 7°C DB, 6°C WB, water temperature 30/35°C.

(2) Average conditions, low temperature, variable - Reg EU 811/2013

(3) Cooling: ambient air temperature 35°C, evaporator water temperature in/out 12/7 °C

(4) Sound power level in accordance with ISO 3744.

(5) Sound pressure level at 10 mt from the unit in free field conditions in accordance with ISO 3744.

PAE N HE U Kr		1001	1201	1401	1601	1802	2002	2302	2502	2802	3202	3602
Heating capacity (EN14511) <sup>(1)</sup>	kW	125,0	156,0	177,0	203,0	221,0	255,0	278,0	307,0	340,0	377,0	433,0
Total input power (EN14511) <sup>(1)</sup>	kW	27,9	34,9	39,3	45,2	50,0	58,3	65,1	70,7	79,5	90,1	99,6
Input current	A	53,0	64,0	69,9	82,8	94,0	104,0	117,0	130,0	140,0	151,0	175,0
COP (EN14511) <sup>(1)</sup>	W/W	4,48	4,47	4,50	4,49	4,42	4,37	4,27	4,34	4,28	4,18	4,35
SCOP	W/W	4,04	4,19	4,20	4,20	3,93	3,84	4,12	4,25	4,28	4,24	4,30
$\eta_{s,h}$ <sup>(2)</sup>	%	159	165	165	165	154	151	162	167	168	167	169
Cooling capacity (EN14511) <sup>(3)</sup>	kW	104,0	127,0	151,0	173,0	184,0	208,0	226,0	260,0	291,0	321,0	365,0
Total input power (EN14511) <sup>(3)</sup>	kW	31,6	40,2	44,6	51,7	57,8	66,9	75,1	79,4	91,7	104,0	117,0
Input current	A	57,5	70,6	76,7	91,2	104,0	115,0	130,0	140,0	15,0	171,0	200,0
EER	W/W	3,29	3,16	3,39	3,35	3,18	3,11	3,01	3,27	3,17	3,09	3,12
Sound power <sup>(4)</sup>	dB(A)	80	82	82	83	82	84	84	84	85	84	86
Sound pressure <sup>(5)</sup>	dB(A)	48	49	50	50	49	52	52	52	52	52	53
Power supply	V/ph/Hz	400/3/50										
Circuits	n°	1	1	1	1	2	2	2	2	2	2	2
Compressors	n°	2	2	2	2	4	4	4	4	4	4	4
Fans	n°	3	3	4	4	6	6	6	8	8	8	10
Refrigerant		R454B	R454B	R454B	R454B	R454B	R454B	R454B	R454B	R454B	R454B	R454B
Refrigerant charge	kg	51	67	67	89	95	126	126	132	132	176	161
Global warming potential	GWP	466	466	466	466	466	466	466	466	466	466	466
Equivalent CO <sub>2</sub> charge	t	24	31	31	41	44	59	59	62	62	82	75
Frame		2	2	3	3	4	4	4	5	5	5	6
Transport weight	kg	1347	1474	1666	1809	2207	2453	2453	2874	3056	3504	3632
Operating weight	kg	1356	1485	1677	1826	2224	2469	2469	2893	3078	3528	3667

PAE N HE U Kr		4202	4802	5202	5602	6002	7004	7504	8504	9504	10004	
Heating capacity (EN14511) <sup>(1)</sup>	kW	489,0	566,0	611,0	656,0	689,0	785,2	893,2	1002,1	1066,3	1165,0	
Total input power (EN14511) <sup>(1)</sup>	kW	110,0	131,0	142,0	154,0	166,0	202,0	226,7	248,5	271,6	294,2	
Input current	A	199,0	222,0	247,0	274,0	300,0	347,9	389,8	426,1	496,1	504,8	
COP (EN14511) <sup>(1)</sup>	W/W	4,45	4,32	4,30	4,26	4,15	3,89	3,94	4,03	3,93	3,96	
SCOP	W/W	4,47	4,27	3,38	3,92	4,00	-	-	-	-	-	
$\eta_{s,h}$ <sup>(2)</sup>	%	176	168	-	-	-	-	-	-	-	-	
Cooling capacity (EN14511) <sup>(3)</sup>	kW	414,0	480,0	528,0	573,0	609,0	683,5	739,8	842,3	928,2	1003,5	
Total input power (EN14511) <sup>(3)</sup>	kW	131,0	155,0	156,0	170,0	182,0	220,6	247,2	274,9	300,0	322,1	
Input current	A	228,0	256,0	286,0	313,0	344,0	372,3	417,6	462,5	532,3	543,1	
EER	W/W	3,16	3,10	3,38	3,37	3,35	3,10	2,99	3,06	3,09	3,12	
Sound power <sup>(4)</sup>	dB(A)	88	86	88	88	92	97	98	99	98	99	
Sound pressure <sup>(5)</sup>	dB(A)	56	54	56	56	60	64	65	66	65	66	
Power supply	V/ph/Hz	400/3/50										
Circuits	n°	2	2	2	2	2	4	4	4	4	4	
Compressors	n°	4	6	6	6	6	8	8	8	12	12	
Fans	n°	10	12	14	14	14	16	20	20	24	24	
Refrigerant		R454B	R454B	R454B	R454B	R454B	R454B	R454B	R454B	R454B	R454B	
Refrigerant charge	kg	214	259	259	308	308	288	275	316	390	462	
Global warming potential	GWP	466	466	466	466	466	466	466	466	466	466	
Equivalent CO <sub>2</sub> charge	t	100	121	107	144	144	134	128	147	182	215	
Frame		6	7	8	8	8	9	10	10	11	11	
Transport weight	kg	3977	4619	4719	5212	5242	7550	7940	8564	9340	9965	
Operating weight	kg	4017	4668	4778	5270	5301	7594	7990	8614	9391	10021	

Performances are referred to the following conditions:

(1) Heating: Ambient temperature 7°C DB, 6°C WB, water temperature 30/35°C.

(2) Average conditions, low temperature, variable - Reg EU 811/2013

(3) Cooling: ambient air temperature 35°C, evaporator water temperature in/out 12/7 °C (only rv versions).

(4) Sound power level in accordance with ISO 3744.

(5) Sound pressure level at 10 mt from the unit in free field conditions in accordance with ISO 3744.

## COMPONENTS

### FRAME

All units are made from hot-galvanised sheet steel, painted with polyurethane powder enamel and stoved at 180°C to provide maximum protection against corrosion. The frame is self-supporting with removable panels. All screws and rivets used are made from stainless steel. The standard colour of the units is RAL9018.

### REFRIGERANT CIRCUIT

The refrigerant circuit is assembled using internationally recognised brand name components with all brazing and welding being performed in accordance with ISO 97/23. The refrigerant utilised are R410A or R454B. The refrigerant circuit includes: sight glass, filter drier, electronic expansion valves, 4 way reversing valve, check valves, liquid receiver, liquid separator, schrader valves for maintenance and control, pressure safety device (for compliance with PED regulations).

### COMPRESSORS

The compressors are scroll type, with crankcase resistance and thermal protection, installed in a separate compartment from the airflow in order to reduce noise. When the unit is on stand-by mode, the crankcase heater is always powered. Through the unit's front panel, it is possible to inspect and repair the compressors even when the unit is running.

The compressors used are tandem type. This solution allows a significantly higher efficiency with partial loads compared to the option with independent refrigerant circuits. The control system constantly monitors the discharge temperature of the single compressors.

### SOURCE HEAT EXCHANGER

The source heat exchanger is made from 3/8" copper pipes and 0,1mm at least thick aluminium fins with the tubes being mechanically expanded into the aluminium fins in order to maximise heat transfer. Furthermore, the design guarantees a low air side pressure drop thus enabling the use of low rotation speed (and hence low noise) fans.

### USER CIRCUIT HEAT EXCHANGERS

The user heat exchanger is a braze welded, plate type heat exchanger, manufactured from AISI 316 stainless steel. The use of this type of exchanger results in a massive reduction of the refrigerant charge of the unit compared to a traditional shell-in-tube type. A further advantage is a reduction in the overall dimensions of the unit. The exchangers are factory insulated with flexible close cell material and can be fitted with an antifreeze heater (accessory). Each exchanger is fitted with a temperature sensor on the discharge water side for antifreeze protection.

### FANS

The fans are direct drive axial type with aerofoil blades, are statically and dynamically balanced and are supplied complete with a safety fan guard complying with the requirements of EN 60335. They are fixed to the unit frame via rubber anti-vibration mountings. The electric motors, in standard versions are 6 poles type with a phase-cut regulator controls or inverter, which modulates its rotation speed according to the air temperature. In the HE versions, the fans are electronic type, with permanent magnet motors with an integrated driver that modulates the speed of rotation. The motors are fitted with integrated thermal overload protection and have a moisture protection rating of IP 54.

### MICROPROCESSORS

All units are supplied as standard with microprocessor controls. The microprocessor controls the following functions: control of the water temperature, antifreeze protection, compressor timing, compressor automatic starting sequence (For multiple compressors), alarm reset.

The control panel is supplied with display showing all operational icons. The microprocessor is set for automatic defrost (when operating in severe ambient conditions) and for summer/ winter change over. The control also manages the integration with other heating sources (electric heaters, boilers, solar panels etc) and both the heating circuit pump and the domestic hot water circuit pump. If required (available as an option), the microprocessor can be configured in order for it to connect to a site BMS system thus enabling remote control and management.

### ELECTRIC ENCLOSURE

The enclosure is manufactured in order to comply with the requirements of the electromagnetic compatibility standards 2014/35/UE and 2014/30/UE. Access to the enclosure is achieved by removing the front panel of the unit. The following components are supplied as standard on all units: main switch, a sequence relay that disables the power supply in the event that the phase sequence is incorrect (scroll compressors can be damaged if they rotate in the wrong direction), thermal overloads (protection of pumps and fans), compressor fuses, control circuit automatic breakers, compressor contactors, fan contactors and pump contactors. The terminal board has volt free contacts for remote ON-OFF, Summer/ winter change over (heat pumps only) and general alarm.

### CONTROL AND PROTECTION DEVICES

All units are standardly equipped with several control and safety devices: water return temperature sensor, installed on the water return pipe of the system, and anti-freeze probe, installed on the water supply pipe to the system high-pressure switch with automatic reset. There are also included a low-pressure automatic reset, pressure transducer (used to optimize the defrosting cycle and modulate the rotation speed of the fans according to external conditions), Freon side safety device, compressor thermal protection, fan thermal protection, flow switch.

### LEAK DETECTOR (R454B VERSION ONLY)

When the unit is powered ON, the sensor is warmed up/initialised (duration approx. 1min.). During this period, the LEDs inside the sensor blink, the refrigerant leakage alarm is notified and the 24Vac auxiliary circuit is switched off. After this period, if in the absence of any further feedback from the sensor, the PLC control is powered up and the unit is ready to operate. If refrigerant leaks occur, the sensor is activated and the power supply to the control PLC is immediately switched off until the sensor indicates the refrigerant is still present.

## VERSION

### Ultrasilenced version (U)

The remarkably low sound level is reached on U versions without sacrificing performance or working limits.

This is done by:

- Adopting refrigerant/air exchangers with wider surfaces than those of the units in standard version.
- Soundproof compressor casing with higher thickness of the soundproof material;
- Fan speed control through variable fixed drive.

### Version with total heat recovery RT

Each model of the range is available in total heat recovery version. In such setting, each cooling circuit is equipped with a refrigerant/water exchanger on gas discharge line. Such exchanger, installed in parallel to the air condenser, it is dimensioned to recover 100% condensing heat for hot sanitary water production.

### Version with partial heat recovery RP

In this configuration, a refrigerant/water heat exchanger is installed on each cooling circuit on gas discharge line. Such exchanger, placed in series and before the air condenser, is sized to recover about 20% of the condensing heat to produce hot sanitary water at medium / high temperatures.

### HE Version

High efficiency version, according to current standard. Unit equipped with EC fans.

## OPERATION LIMITS

### Standard version

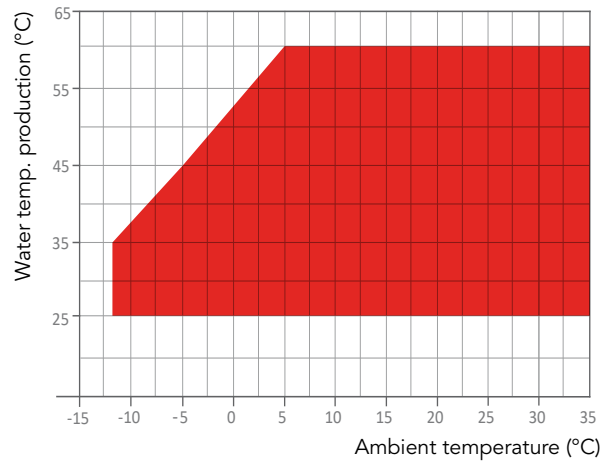
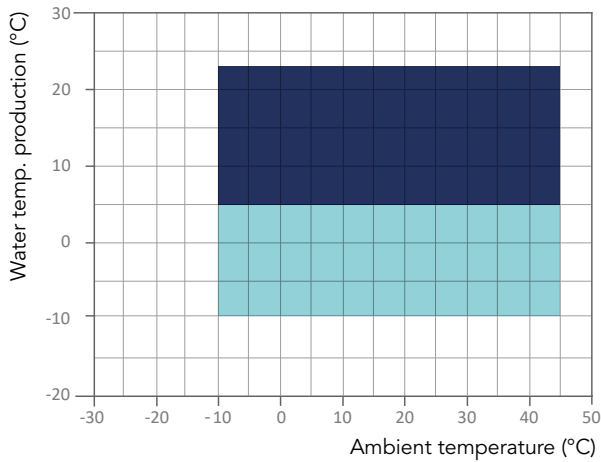

### HE version

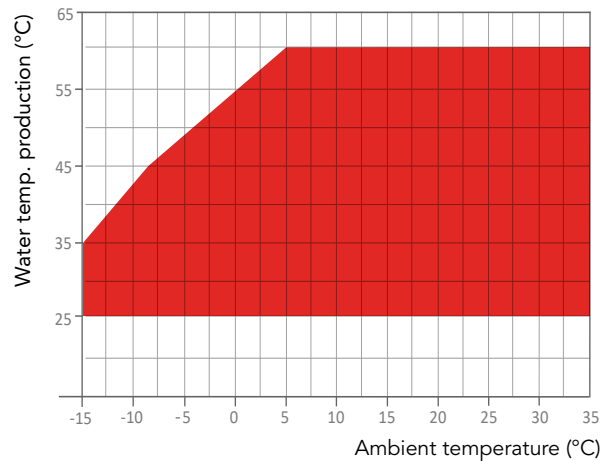
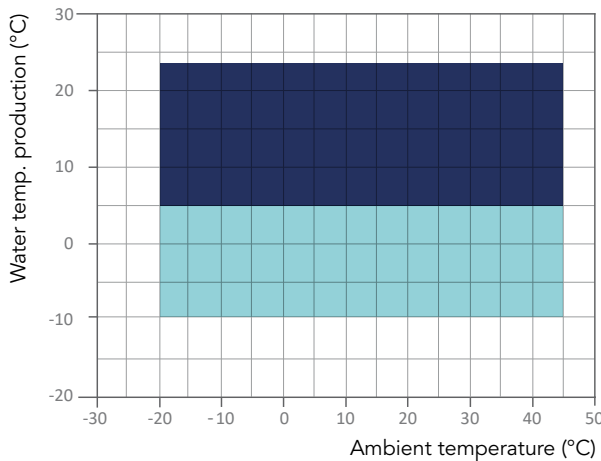

■ Cooling mode  
■ Glycol set-up

■ Heating mode

# ACCESSORIES

PAE N Kc/Kr		601	801	1001	1201	1401	1601	1801	1802	2002	2101	2302	2502	2802
Amperometer	<b>A</b>	○	○	○	○	○	○	○	○	○	○	○	○	○
Electrical power supply different than standard	<b>AE</b>	○	○	○	○	○	○	○	○	○	○	○	○	○
Electrofin Coil Treatment	<b>BEF</b>	○	○	○	○	○	○	○	○	○	○	○	○	○
Operation in cooling mode down to -20°C	<b>BF</b> <sup>(1)</sup>	○	○	○	○	○	○	○	○	○	○	○	○	○
Operation in cooling mode down to -10°C	<b>BT</b> <sup>(1)</sup>	●	●	●	●	●	●	●	●	●	●	●	●	●
Soundproofed compressors cabinet with standard material	<b>CF</b>	●	●	●	●	●	●	●	●	●	●	●	●	●
Soundproofed compressors cabinet with higher thickness material	<b>CFU</b> <sup>(2)</sup>	○	○	○	○	○	○	○	○	○	○	○	○	○
Soundproofing jacket on compressors	<b>CI</b>	○	○	○	○	○	○	○	○	○	○	○	○	○
Compressors inrush counter	<b>CS</b>	○	○	○	○	○	○	○	○	○	○	○	○	○
Refrigerant leakage detector	<b>DR</b> <sup>(3)</sup>	●	●	●	●	●	●	●	●	●	●	●	●	●
Axial fans with electronic commutated motor	<b>EC</b> <sup>(4)</sup>	○	○	○	○	○	○	○	○	○	○	○	○	○
Condensing coil protection grid	<b>GP</b>	○	○	○	○	○	○	○	○	○	○	○	○	○
Anti-intrusion grid	<b>GP2</b> <sup>(5)</sup>	○	○	○	○	○	○	○	○	○	○	○	○	○
Anti-intrusion grid	<b>GP3</b>	○	○	○	○	○	○	○	○	○	○	○	○	○
Victaulic insulation on pump side	<b>I1</b>	○	○	○	○	○	○	○	○	○	○	○	○	○
Victaulic insulation buffer tank side	<b>I2</b>	○	○	○	○	○	○	○	○	○	○	○	○	○
RS 485 Serial interface	<b>IH</b>	○	○	○	○	○	○	○	○	○	○	○	○	○
Seawood packing	<b>IM</b>	○	○	○	○	○	○	○	○	○	○	○	○	○
TCP/IP Protocol serial interface	<b>IWG</b>	○	○	○	○	○	○	○	○	○	○	○	○	○
Phase monitor	<b>MF</b>	○	○	○	○	○	○	○	○	○	○	○	○	○
Buffer tank module	<b>MV</b>	○	○	○	○	○	○	○	○	○	○	○	○	○
Pump group	<b>P1</b>	○	○	○	○	○	○	○	○	○	○	○	○	○
Pump + tank	<b>P1+MV</b>	○	○	○	○	○	○	○	○	○	○	○	○	○
Pump Variable flow 2 Poles high prevalence	<b>P12HVS</b> <sup>(6)</sup>	○	○	○	○	○	○	○	○	○	○	○	○	○
Pump Variable flow 2 Poles high prevalence + tank	<b>P12HVS+MV</b> <sup>(5)</sup>	○	○	○	○	○	○	○	○	○	○	○	○	○
Pump Variable flow 2 Poles	<b>P12VS</b> <sup>(6)</sup>	○	○	○	○	○	○	○	○	○	○	○	○	○
Pump Variable flow 2 Poles + tank	<b>P12VS+MV</b> <sup>(5)</sup>	○	○	○	○	○	○	○	○	○	○	○	○	○
Higher available pressure pump group	<b>P1H</b>	○	○	○	○	○	○	○	○	○	○	○	○	○
Higher available pressure pump group + tank	<b>P1H+MV</b>	○	○	○	○	○	○	○	○	○	○	○	○	○
Double pump group	<b>P2</b>	○	○	○	○	○	○	○	○	○	○	○	○	○
Double pump group + tank	<b>P2+MV</b>	○	○	○	○	○	○	○	○	○	○	○	○	○
Double pump group Variable flow 2 Poles	<b>P22HVS</b> <sup>(6)</sup>	○	○	○	○	○	○	○	○	○	○	○	○	○
Double pump group Variable flow 2 Poles + tank	<b>P22HVS+MV</b> <sup>(6)</sup>	○	○	○	○	○	○	○	○	○	○	○	○	○
Double pump group Variable flow 2 Poles	<b>P22VS</b> <sup>(6)</sup>	○	○	○	○	○	○	○	○	○	○	○	○	○
Double pump group Variable flow 2 Poles + tank	<b>P22VS+MV</b> <sup>(5)</sup>	○	○	○	○	○	○	○	○	○	○	○	○	○
Higher available pressure double pump group	<b>P2H</b>	○	○	○	○	○	○	○	○	○	○	○	○	○
Higher available pressure double pump group + tank	<b>P2H+MV</b>	○	○	○	○	○	○	○	○	○	○	○	○	○
Rubber-type vibration dampers	<b>PA</b>	○	○	○	○	○	○	○	○	○	○	○	○	○
Spring-type vibration dampers	<b>PM</b>	○	○	○	○	○	○	○	○	○	○	○	○	○
Remote display	<b>PQ</b>	○	○	○	○	○	○	○	○	○	○	○	○	○
In-line twin pump group (only one working)	<b>PT</b>	○	○	○	○	○	○	○	○	○	○	○	○	○
In-line twin pump group (only one working) + tank	<b>PT+MV</b>	○	○	○	○	○	○	○	○	○	○	○	○	○
In-line twin pump group Variable flow	<b>PTVS</b>	○	○	○	○	○	○	○	○	○	○	○	○	○
In-line twin pump group Variable flow + tank	<b>PTVS+MV</b>	○	○	○	○	○	○	○	○	○	○	○	○	○
Anti-freeze heater on evaporator	<b>RA</b>	○	○	○	○	○	○	○	○	○	○	○	○	○
Shut-off valve on compressors discharge side	<b>RD</b>	○	○	○	○	○	○	○	○	○	○	○	○	○
Power factor correction system cosφ ≥ 0,9	<b>RF</b>	○	○	○	○	○	○	○	○	○	○	○	○	○
Shut-off valve on compressors suction side	<b>RH</b>	○	○	○	○	○	○	○	○	○	○	○	○	○
Compressor overload relays	<b>RL</b>	○	○	○	○	○	○	○	○	○	○	○	○	○
Prepainted fins coil	<b>RM</b>	○	○	○	○	○	○	○	○	○	○	○	○	○
Partial heat recovery	<b>RP</b> <sup>(5)</sup>	○	○	○	○	○	○	○	○	○	○	○	○	○
Copper/Copper coil	<b>RR</b>	○	○	○	○	○	○	○	○	○	○	○	○	○
Electronic thermostatic valve	<b>TE</b>	●	●	●	●	●	●	●	●	●	●	●	●	●
Voltmeter	<b>V</b>	○	○	○	○	○	○	○	○	○	○	○	○	○
Brine Version	<b>VB</b>	○	○	○	○	○	○	○	○	○	○	○	○	○
Solenoid valve	<b>VS</b>	○	○	○	○	○	○	○	○	○	○	○	○	○

(1) Not available for HE versions

(2) Standard for U versions

(3) Available only with R454B (Kr)

(4) Standard for HE versions

(5) In U versions, available only with R410A (Kc)

(6) 4 poles for U versions (P14 / P24)

● Standard ○ Optional – Not available

PAE N Kc/Kr		3202	3602	4202	4802	5202	5602	6002	7004	7504	8504	9504	10004	11004
Amperometer	<b>A</b>	○	○	○	○	○	○	○	○	○	○	○	○	○
Electrical power supply different than standard	<b>AE</b>	○	○	○	○	○	○	○	○	○	○	○	○	○
Electrofin Coil Treatment	<b>BEF</b>	○	○	○	○	○	○	○	○	○	○	○	○	○
Operation in cooling mode down to -20°C	<b>BF</b> <sup>(1)</sup>	○	○	○	○	○	○	○	○	○	○	○	○	○
Operation in cooling mode down to -10°C	<b>BT</b> <sup>(1)</sup>	●	●	●	●	●	●	○	○	○	○	○	○	○
Soundproofed compressors cabinet with standard material	<b>CF</b>	●	●	●	●	●	●	●	●	●	●	●	●	●
Soundproofed compressors cabinet with higher thickness material	<b>CFU</b> <sup>(2)</sup>	○	○	○	○	○	○	○	○	○	○	○	○	○
Soundproofing jacket on compressors	<b>CI</b>	○	○	○	○	○	○	○	○	○	○	○	○	○
Compressors inrush counter	<b>CS</b>	○	○	○	○	○	○	○	○	○	○	○	○	○
Refrigerant leakage detector	<b>DR</b> <sup>(3)</sup>	●	●	●	●	●	●	●	●	●	●	●	●	●
Axial fans with electronic commutated motor	<b>EC</b> <sup>(4)</sup>	○	○	○	○	○	○	●	●	●	●	●	●	●
Condensing coil protection grid	<b>GP</b>	○	○	○	○	○	○	○	○	○	○	○	○	○
Anti-intrusion grid	<b>GP2</b> <sup>(5)</sup>	○	○	○	○	○	○	○	○	○	○	○	○	○
Anti-intrusion grid	<b>GP3</b>	○	○	○	○	○	○	○	○	○	○	○	○	○
Victaulic insulation on pump side	<b>I1</b>	○	○	○	○	○	○	○	○	○	○	○	○	○
Victaulic insulation buffer tank side	<b>I2</b>	○	○	○	○	○	○	○	○	○	○	○	○	○
RS 485 Serial interface	<b>IH</b>	○	○	○	○	○	○	○	○	○	○	○	○	○
Seawood packing	<b>IM</b>	○	○	○	○	○	○	○	○	○	○	○	○	○
TCP/IP Protocol serial interface	<b>IWG</b>	○	○	○	○	○	○	○	○	○	○	○	○	○
Phase monitor	<b>MF</b>	○	○	○	○	○	○	○	○	○	○	○	○	○
Buffer tank module	<b>MV</b>	○	○	○	○	○	○	○	○	○	○	○	○	○
Pump group	<b>P1</b>	○	○	○	○	○	○	○	○	○	○	○	○	○
Pump + tank	<b>P1+MV</b>	○	○	○	○	○	○	○	○	○	○	○	○	○
Pump Variable flow 2 Poles high prevalence	<b>P12HVS</b> <sup>(6)</sup>	○	○	○	○	○	○	○	○	○	○	○	○	○
Pump Variable flow 2 Poles high prevalence + tank	<b>P12HVS+MV</b> <sup>(5)</sup>	○	○	○	○	○	○	○	○	○	○	○	○	○
Pump Variable flow 2 Poles	<b>P12VS</b> <sup>(6)</sup>	○	○	○	○	○	○	○	○	○	○	○	○	○
Pump Variable flow 2 Poles + tank	<b>P12VS+MV</b> <sup>(5)</sup>	○	○	○	○	○	○	○	○	○	○	○	○	○
Higher available pressure pump group	<b>P1H</b>	○	○	○	○	○	○	○	○	○	○	○	○	○
Higher available pressure pump group + tank	<b>P1H+MV</b>	○	○	○	○	○	○	○	○	○	○	○	○	○
Double pump group	<b>P2</b>	○	○	○	○	○	○	○	○	○	○	○	○	○
Double pump group + tank	<b>P2+MV</b>	○	○	○	○	○	○	○	○	○	○	○	○	○
Double pump group Variable flow 2 Poles	<b>P22HVS</b> <sup>(6)</sup>	○	○	○	○	○	○	○	○	○	○	○	○	○
Double pump group Variable flow 2 Poles + tank	<b>P22HVS+MV</b> <sup>(6)</sup>	○	○	○	○	○	○	○	○	○	○	○	○	○
Double pump group Variable flow 2 Poles	<b>P22VS</b> <sup>(6)</sup>	○	○	○	○	○	○	○	○	○	○	○	○	○
Double pump group Variable flow 2 Poles + tank	<b>P22VS+MV</b> <sup>(5)</sup>	○	○	○	○	○	○	○	○	○	○	○	○	○
Higher available pressure double pump group	<b>P2H</b>	○	○	○	○	○	○	○	○	○	○	○	○	○
Higher available pressure double pump group + tank	<b>P2H+MV</b>	○	○	○	○	○	○	○	○	○	○	○	○	○
Rubber-type vibration dampers	<b>PA</b>	○	○	○	○	○	○	○	○	○	○	○	○	○
Spring-type vibration dampers	<b>PM</b>	○	○	○	○	○	○	○	○	○	○	○	○	○
Remote display	<b>PQ</b>	○	○	○	○	○	○	○	○	○	○	○	○	○
In-line twin pump group (only one working)	<b>PT</b>	○	○	○	○	○	○	○	○	○	○	○	○	○
In-line twin pump group (only one working) + tank	<b>PT+MV</b>	○	○	○	○	○	○	○	○	○	○	○	○	○
In-line twin pump group Variable flow	<b>PTVS</b>	○	○	○	○	○	○	○	○	○	○	○	○	○
In-line twin pump group Variable flow + tank	<b>PTVS+MV</b>	○	○	○	○	○	○	○	○	○	○	○	○	○
Anti-freeze heater on evaporator	<b>RA</b>	○	○	○	○	○	○	○	○	○	○	○	○	○
Shut-off valve on compressors discharge side	<b>RD</b>	○	○	○	○	○	○	○	○	○	○	○	○	○
Power factor correction system cosfi ≥0,9	<b>RF</b>	○	○	○	○	○	○	○	○	○	○	○	○	○
Shut-off valve on compressors suction side	<b>RH</b>	○	○	○	○	○	○	○	○	○	○	○	○	○
Compressor overload relays	<b>RL</b>	○	○	○	○	○	○	○	○	○	○	○	○	○
Prepainted fins coil	<b>RM</b>	○	○	○	○	○	○	○	○	○	○	○	○	○
Partial heat recovery	<b>RP</b> <sup>(5)</sup>	○	○	○	○	○	○	○	○	○	○	○	○	○
Copper/Copper coil	<b>RR</b>	○	○	○	○	○	○	○	○	○	○	○	○	○
Electronic thermostatic valve	<b>TE</b>	●	●	●	●	●	●	●	●	●	●	●	●	●
Voltmeter	<b>V</b>	○	○	○	○	○	○	○	○	○	○	○	○	○
Brine Version	<b>VB</b>	○	○	○	○	○	○	○	○	○	○	○	○	○
Solenoid valve	<b>VS</b>	○	○	○	○	○	○	○	○	○	○	○	○	○

(1) Not available for HE versions

(2) Standard for U versions

(3) Available only with R454B (Kr)

(4) Standard for HE versions

(5) In U versions, available only with R410A (Kc)

(6) 4 poles for U versions (P14 / P24)

● Standard ○ Optional – Not available

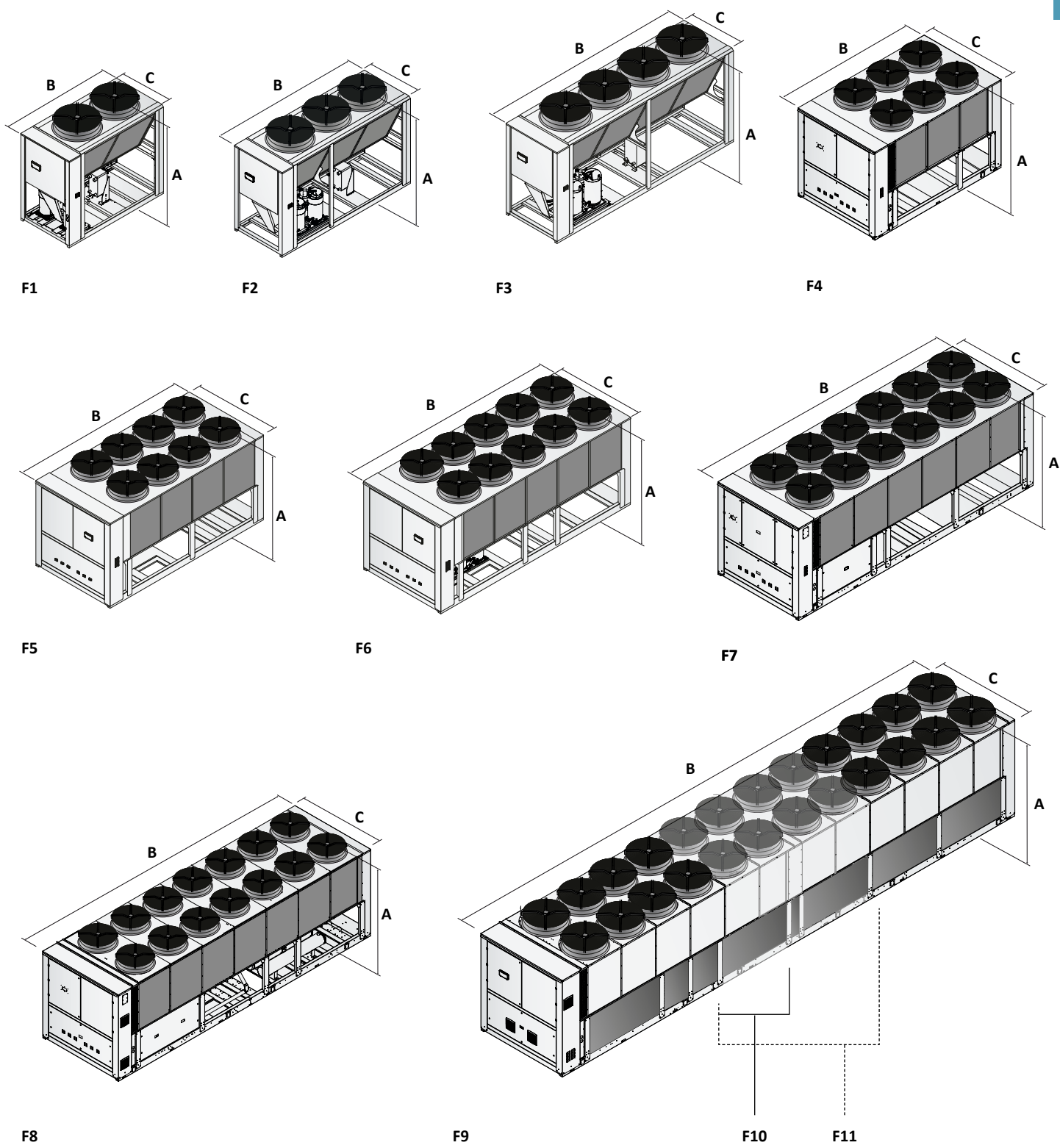

FRAME	F1	F2	F3	F4	F5	F6	F7	F8	F9	F10	F11
A (mm)	2420	2420	2420	2560	2560	2560	2560	2560	2560	2560	2560
B (mm)	2660	3700	4740	3775	4750	5725	6700	7250	9800	10680	12780
C (mm)	1370	1370	1370	2300	2300	2300	2300	2300	2300	2300	2300

# PAH VS

## HIGH EFFICIENCY AIR TO WATER HEAT PUMPS EQUIPPED WITH INVERTER SCREW COMPRESSORS AND AXIAL FAN

Heating power from 480 kW to 1380 kW

R513A



Packaged air cooled heat pumps of PAH VS Ke series are suitable for outdoor installation and can be used to cool and heat fluid solutions for air conditioning or in industrial applications. The SEMI-HERMETIC SCREW compressor technology with INVERTER motor control, constantly modulating, guarantees a high capacity of partialisation of the cooling and heating power supplied, with a consequent increase in seasonal efficiency, also in applications with highly variable loads. All the units are totally factory assembled and tested, following specific quality procedures. Besides they are totally hydraulic, cooling and electrical connected permitting a quick installation once on site. Before the test the cooling circuits of each unit are subjected to a pressure test and then charged with Refrigerant R513A and non-freezing oil.

### VERSIONI

**HE** High efficiency, EC fans.  
**U** Ultra low noise.

## TECHNICAL DATA

PAH VS Ke		402	502	602	702	802	902	1002	1102
Heating capacity (EN14511) <sup>(1)</sup>	kW	496,5	622,1	706,6	821,9	980,6	1091,8	1266,9	1343,1
Total input power (EN14511) <sup>(1)</sup>	kW	122,3	154,5	176,8	206,5	237,2	268,9	297,0	330,0
Input current	A	205,9	260,1	297,6	347,6	399,4	452,8	500,1	555,6
COP (EN14511) <sup>(1)</sup>	W/W	4,06	4,03	4,00	3,98	4,13	4,06	4,27	4,07
SEER	W/W	4,59	4,58	4,60	4,59	4,60	4,63	4,62	4,60
Cooling capacity (EN14511) <sup>(2)</sup>	kW	412,0	521,2	624,2	723,1	808,6	908,5	1050,6	1112,4
Total input power (EN14511) <sup>(2)</sup>	kW	155,1	193,0	217,4	251,6	290,8	334,9	367,1	416,5
Input current	A	261,1	324,9	365,9	423,6	489,5	563,8	618,0	701,2
EER	W/W	2,66	2,70	2,87	2,87	2,78	2,71	2,86	2,67
Sound power <sup>(3)</sup>	dB(A)	97	99	99	100	100	101	102	102
Sound pressure <sup>(4)</sup>	dB(A)	64,5	66,0	66,0	67,0	67,0	68,0	69,0	69,0
Power supply	V/ph/Hz	400/3/50	400/3/50	400/3/50	400/3/50	400/3/50	400/3/50	400/3/50	400/3/50
Circuits	n°	2	2	2	2	2	2	2	2
Compressors	n°	2	2	2	2	2	2	2	2
Fans	n°	8	10	12	14	16	20	20	20
Refrigerant		R513A	R513A	R513A	R513A	R513A	R513A	R513A	R513A
Refrigerant charge	kg	158	177	340	452	478	515	537	551
Global warming potential (GWP)		573	573	573	573	573	573	573	573
Equivalent CO <sub>2</sub> charge	t	91	101	195	259	274	295	308	316

PAH VS U Ke		402	502	602	702	802	902	1002	1102
Heating capacity (EN14511) <sup>(1)</sup>	kW	480,0	607,7	708,6	836,4	943,5	1106,2	1163,9	1318,4
Total input power (EN14511) <sup>(1)</sup>	kW	115,6	145,6	166,2	194,3	223,5	248,6	278,1	312,5
Input current	A	194,6	245,2	279,9	327,0	376,3	418,5	468,2	526,1
COP (EN14511) <sup>(1)</sup>	W/W	4,15	4,17	4,26	4,31	4,22	4,45	4,19	4,22
SEER	W/W	4,58	4,58	4,60	4,60	4,58	4,61	4,63	4,58
Cooling capacity (EN14511) <sup>(2)</sup>	kW	407,9	517,1	606,7	704,5	811,6	918,8	1040,3	1133,0
Total input power (EN14511) <sup>(2)</sup>	kW	150,4	188,7	212,4	248,4	284,3	311,8	354,3	395,5
Input current	A	253,2	317,7	357,6	418,2	478,6	524,9	596,5	665,9
EER	W/W	2,71	2,74	2,86	2,84	2,86	2,95	2,94	2,86
Sound power <sup>(3)</sup>	dB(A)	92	94	94	95	96	97	98	98
Sound pressure <sup>(4)</sup>	dB(A)	60	61	61	62	63	64	65	65
Power supply	V/ph/Hz	400/3/50	400/3/50	400/3/50	400/3/50	400/3/50	400/3/50	400/3/50	400/3/50
Circuits	n°	2	2	2	2	2	2	2	2
Compressors	n°	2	2	2	2	2	2	2	2
Fans	n°	10	12	14	16	20	20	24	24
Refrigerant		R513A	R513A	R513A	R513A	R513A	R513A	R513A	R513A
Refrigerant charge	kg	177	197	452	478	537	551	621	649
Global warming potential (GWP)		573	573	573	573	573	573	573	573
Equivalent CO <sub>2</sub> charge	t	101	113	259	274	308	316	356	372

Performances are referred to the following conditions:

(1) Heating: Ambient temperature 7°C DB, 6°C WB, water temperature 30/35°C.

(2) Cooling: ambient air temperature 35°C, evaporator water temperature in/out 12/7 °C

(3) Sound power level in accordance with ISO 3744.

(4) Sound pressure level at 10 mt from the unit in free field conditions in accordance with ISO 3744.

PAH VS HE Ke		402	502	602	702	802	902	1002	1102
Heating capacity (EN14511) <sup>(1)</sup>	kW	516,6	645,8	739,2	871,5	995,4	1113,0	1269,5	1375,5
Total input power (EN14511) <sup>(1)</sup>	kW	121,4	149,4	173,1	196,1	229,8	251,6	314,3	356,9
Input current	A	204,4	251,4	291,4	330,1	386,9	423,6	529,2	600,9
COP (EN14511) <sup>(1)</sup>	W/W	4,26	4,32	4,27	4,44	4,33	4,42	4,04	3,85
SEER	W/W	5,25	5,57	5,47	5,15	5,35	5,44	5,60	5,68
Cooling capacity (EN14511) <sup>(2)</sup>	kW	462,0	581,7	661,5	783,3	905,1	1000,7	1146,6	1239,0
Total input power (EN14511) <sup>(2)</sup>	kW	150,8	179,4	209,9	243,3	289,6	311,6	363,9	381,9
Input current	A	253,9	302,0	353,4	409,6	487,5	524,6	612,7	643,0
EER	W/W	3,06	3,24	3,15	3,22	3,13	3,21	3,15	3,24
Sound power <sup>(3)</sup>	dB(A)	95	96	101	99	100	101	100	101
Sound pressure <sup>(4)</sup>	dB(A)	63	64	69	66	67	68	67	68
Power supply	V/ph/Hz	400/3/50	400/3/50	400/3/50	400/3/50	400/3/50	400/3/50	400/3/50	400/3/50
Circuits	n°	2	2	2	2	2	2	2	2
Compressors	n°	2	2	2	2	2	2	2	2
Fans	n°	10	12	14	16	20	20	24	24
Refrigerant		R513A	R513A	R513A	R513A	R513A	R513A	R513A	R513A
Refrigerant charge	kg	185	205	478	515	557	580	656	680
Global warming potential (GWP)		573	573	573	573	573	573	573	573
Equivalent CO <sub>2</sub> charge	t	106	117	274	295	319	332	376	390

PAH VS HE U Ke		402	502	602	702	802	902	1002
Heating capacity (EN14511) <sup>(1)</sup>	kW	485,1	627,9	716,1	844,2	963,9	1131,9	1281,0
Total input power (EN14511) <sup>(1)</sup>	kW	106,1	137,4	159,4	185,8	207,0	272,2	293,8
Input current	A	178,6	231,3	268,4	312,8	348,5	458,3	494,5
COP (EN14511) <sup>(1)</sup>	W/W	4,57	4,57	4,49	4,54	4,66	4,16	4,36
SEER	W/W	5,37	5,47	5,47	5,11	5,27	5,33	5,46
Cooling capacity (EN14511) <sup>(2)</sup>	kW	443,1	562,8	621,6	758,1	875,7	1010,1	1129,8
Total input power (EN14511) <sup>(2)</sup>	kW	140,1	177,2	198,8	243,1	284,3	335,8	359,5
Input current	A	235,8	298,2	334,7	409,2	478,6	565,3	605,2
EER	W/W	3,16	3,18	3,13	3,12	3,08	3,01	3,14
Sound power <sup>(3)</sup>	dB(A)	89	90	97	96	97	95	96
Sound pressure <sup>(4)</sup>	dB(A)	57	58	65	63	64	62,	63
Power supply	V/ph/Hz	400/3/50	400/3/50	400/3/50	400/3/50	400/3/50	400/3/50	400/3/50
Circuits	n°	2	2	2	2	2	2	2
Compressors	n°	2	2	2	2	2	2	2
Fans	n°	12	14	16	20	20	24	24
Refrigerant		R513A	R513A	R513A	R513A	R513A	R513A	R513A
Refrigerant charge	kg	205	248	515	557	580	656	680
Global warming potential (GWP)		573	573	573	573	573	573	573
Equivalent CO <sub>2</sub> charge	t	117	142	295	319	332	376	390

Performances are referred to the following conditions:

(1) Heating: Ambient temperature 7°C DB, 6°C WB, water temperature 30/35°C.

(2) Cooling: ambient air temperature 35°C, evaporator water temperature in/out 12/7 °C

(3) Sound power level in accordance with ISO 3744.

(4) Sound pressure level at 10 mt from the unit in free field conditions in accordance with ISO 3744.

## COMPONENTS

### FRAME

All units are made from hot-galvanised sheet steel, painted with polyurethane powder enamel and stoved at 180°C to provide maximum protection against corrosion. The frame is self-supporting with removable panels. All screws and rivets used are made from stainless steel. The standard colour of the units is RAL9018.

### COOLING CIRCUITS

The refrigerant circuit is assembled using internationally recognised brand name components with all brazing and welding being performed in accordance with ISO 97/23. The refrigerant

utilised is R513A. The refrigerant circuit includes: sight glass, filter drier, electronic expansion valves, 4 way reversing valve, check valves, liquid receiver, liquid separator, schrader valves for maintenance and control, pressure safety device (for compliance with PED regulations).

### COMPRESSOR

Compressors of semi-hermetic screw type, controlled by integrated frequency inverter, allowing to adapt the power to the load variations ensuring at the same time the maximum efficiency at different operating conditions. The compressors are provided

with motor thermal protection, rotation direction control, crankcase heater, oil filter, oil service valve, POE oil charge and vibration dumpers kit. Compressors lubrication is of forced type without pump, to avoid excessive oil migrations to the cooling circuit, compressors are equipped with an oil separator on discharge side. Both compressors are equipped with an oil flow safety switch, an optoelectronic device operating in case the oil flow inside the compressor falls below the minimum threshold.

### SOURCE HEAT EXCHANGER

Finned pack type, Copper/Aluminium, with micro-finned copper tubes, positioned in staggered rows and mechanically expanded into an aluminium finned pack. Fins are designed with such a shape providing the highest heat exchange efficiency. The max operating pressure refrigerant side is 45 relative bar.

### USER HEAT EXCHANGERS (SIZE 402-502)

The user heat exchanger is a braze welded, plate type heat exchanger, manufactured from AISI 316 stainless steel. The use of this type of exchanger results in a massive reduction of the refrigerant charge of the unit compared to a traditional shell-in-tube type. A further advantage is a reduction in the overall dimensions of the unit. The exchangers are factory insulated with flexible close cell material and can be fitted with an antifreeze heater (accessory). Each exchanger is fitted with a temperature sensor on the discharge water side for antifreeze protection.

### USER HEAT EXCHANGERS (SIZE 602-1102)

Tube bundle type with dry expansion and pure electrolytic copper tubes, shell and tube plate made up of carbon steel. The exchanger is provided with anti-condensation insulation made up of a nitrile rubber and polyethylene foam with a thickness of 8mm externally protected by an embossed scratchproof polyethylene film. The hydraulic connection are of elastic Victaulic type. Inside the shell, some plastic and corrosion-proof baffles, allowing a correct water distribution and making the tube bundle particularly strong and vibration free, even with high water flows. The evaporator is also provided with a safety water flow switch that does not allow the unit to operate in case of water flow rate lack to the evaporator.

### FANS

The fans are direct drive axial type with aerofoil blades, are statically and dynamically balanced and are supplied complete with a safety fan guard complying with the requirements of EN 60335. They are fixed to the unit frame via rubber anti-vibration mountings. The electric motors are electronic type, with permanent magnet motors with an integrated driver that modulates the speed of rotation. The motors are fitted with integrated thermal overload protection and have a moisture protection rating of IP 54.

### MICROPROCESSORS

All units are supplied as standard with microprocessor controls. The microprocessor controls the following functions: control of the water temperature, antifreeze protection, compressor timing, compressor automatic starting sequence (For multiple compressors), alarm reset. The control panel is supplied with display showing all operational icons. The microprocessor is set for automatic defrost (when operating in severe ambient conditions) and for summer/ winter change over. The control also manages the integration with other heating sources (electric heaters, boilers, solar panels etc) and both the heating circuit pump and the domestic hot water circuit pump. If required (available as an option), the microprocessor can be configured in order for it to connect to a site BMS system thus enabling remote control and management.

### ELECTRIC ENCLOSURE

The enclosure is manufactured in order to comply with the requirements of the electromagnetic compatibility standards 2014/35/UE

and 2014/30/UE. Access to the enclosure is achieved by removing the front panel of the unit. The following components are supplied as standard on all units: main switch, a sequence relay that disables the power supply in the event that the phase sequence is incorrect (scroll compressors can be damaged if they rotate in the wrong direction), thermal overloads (protection of pumps and fans), compressor fuses, control circuit automatic breakers, compressor contactors, fan contactors and pump contactors. The terminal board has volt free contacts for remote ON-OFF, Summer/ winter change over (heat pumps only) and general alarm.

### CONTROL AND PROTECTION DEVICES

All units are standardly equipped with several control and safety devices: water return temperature sensor, installed on the water return pipe of the system, and anti-freeze probe, installed on the water supply pipe to the system high-pressure switch with automatic reset. There are also included a low-pressure automatic reset, pressure transducer (used to optimize the defrosting cycle and modulate the rotation speed of the fans according to external conditions), Freon side safety device, compressor thermal protection, fan thermal protection, flow switch.

## VERSIONS

### Ultrasilenced version (U)

The remarkably low sound level is reached on U versions without sacrificing performance or working limits.

This is done by:

- Adopting refrigerant/air exchangers with wider surfaces than those of the units in standard version.
- Soundproof compressor casing with higher thickness of the soundproof material;
- Fan speed control through variable fixed drive.

### Version with partial heat recovery RP

In this configuration, a refrigerant/water heat exchanger is installed on each cooling circuit on gas discharge line. Such exchanger, placed in series and before the air condenser, is sized to recover about 20% of the condensing heat to produce hot sanitary water at medium / high temperatures.

# OPERATION LIMITS

## Standard version

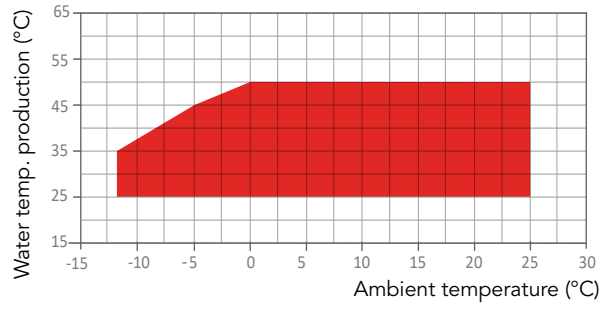
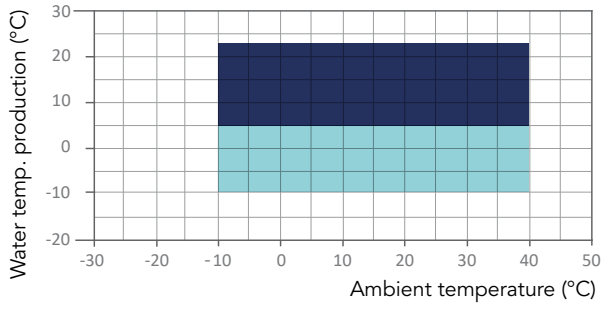

## HE version

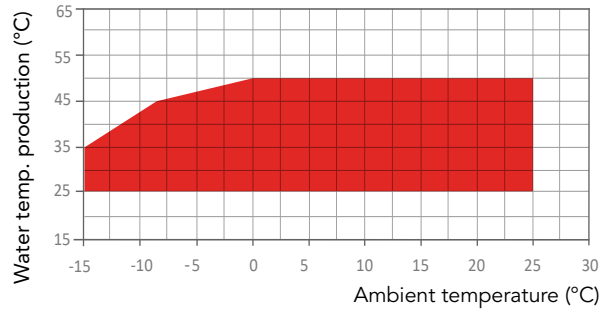
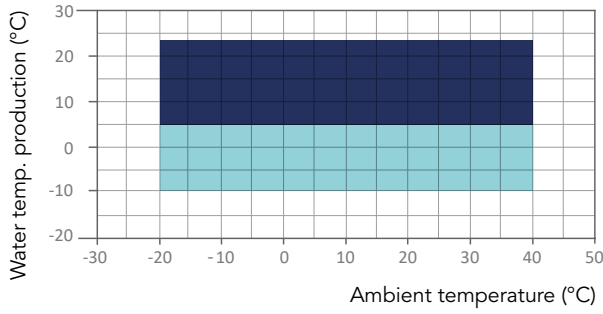

■ Cooling mode  
■ Glycol set-up

■ Heating mode

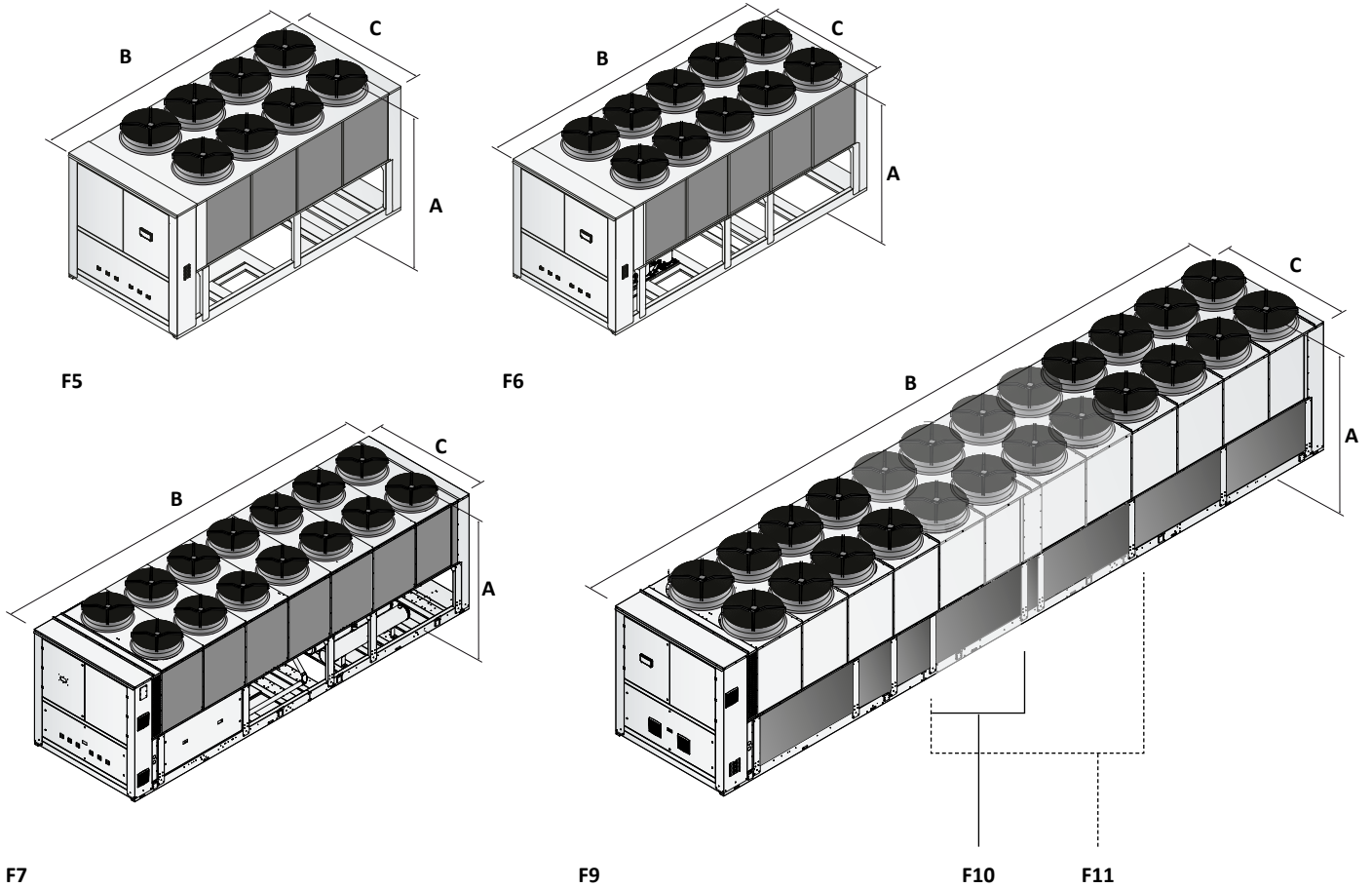

FRAME	F5	F6	F7	F8	F9	F10	F11
A (mm)	2560	2560	2560	2560	2560	2560	2560
B (mm)	4750	5725	6700	7250	9800	10680	12780
C (mm)	2300	2300	2300	2300	2300	2300	2300

## ACCESSORIES

PAH VS Ke		402	502	602	702	802	902	1002	1102
Amperometer	<b>A</b>	○	○	○	○	○	○	○	○
Electrical power supply different than standard	<b>AE</b>	○	○	○	○	○	○	○	○
Electrofin Coil Treatment	<b>BEF</b>	○	○	○	○	○	○	○	○
Operation in cooling mode down to -20°C	<b>BF</b>	○	○	○	○	○	○	○	○
Soundproofed compressors cabinet with standard material	<b>CF</b>	●	●	●	●	●	●	●	●
Soundproofed compressors cabinet with higher thickness material	<b>CFU</b> <sup>(1)</sup>	○	○	○	○	○	○	○	○
Soundproofing jacket on compressors	<b>CI</b>	○	○	○	○	○	○	○	○
Compressors inrush counter	<b>CS</b>	○	○	○	○	○	○	○	○
Condensing coil protection grid	<b>GP</b>	○	○	○	○	○	○	○	○
Anti-intrusion grid	<b>GP3</b>	○	○	○	○	○	○	○	○
Victaulic insulation on pump side	<b>I1</b>	○	○	○	○	○	○	○	○
Victaulic insulation buffer tank side	<b>I2</b>	○	○	○	○	○	○	○	○
RS 485 Serial interface	<b>IH</b>	○	○	○	○	○	○	○	○
Seawood packing	<b>IM</b>	○	○	○	○	○	○	○	○
TCP/IP Protocol serial interface	<b>IWG</b>	○	○	○	○	○	○	○	○
Phase monitor	<b>MF</b>	○	○	○	○	○	○	○	○
Buffer tank module	<b>MV</b>	○	○	○	○	○	○	○	○
Pump group	<b>P1</b>	○	○	○	○	○	○	○	○
Pump + tank	<b>P1+MV</b>	○	○	○	○	○	○	○	○
Pump Variable flow 2 Poles high prevalence	<b>P12HVS</b> <sup>(2)</sup>	○	○	○	○	○	○	○	○
Pump Variable flow 2 Poles high prevalence + tank	<b>P12HVS+MV</b> <sup>(2)</sup>	○	○	○	○	○	○	○	○
Pump Variable flow 2 Poles	<b>P12VS</b> <sup>(2)</sup>	○	○	○	○	○	○	○	○
Pump Variable flow 2 Poles + tank	<b>P12VS+MV</b> <sup>(2)</sup>	○	○	○	○	○	○	○	○
Higher available pressure pump group	<b>P1H</b>	○	○	○	○	○	○	○	○
Higher available pressure pump group + tank	<b>P1H+MV</b>	○	○	○	○	○	○	○	○
Double pump group	<b>P2</b>	○	○	○	○	○	○	○	○
Double pump group + tank	<b>P2+MV</b>	○	○	○	○	○	○	○	○
Double pump group Variable flow 2 Poles high prevalence	<b>P22HVS</b> <sup>(2)</sup>	○	○	○	○	○	○	○	○
Double pump group Variable flow 2 Poles high prevalence + tank	<b>P22HVS+MV</b> <sup>(2)</sup>	○	○	○	○	○	○	○	○
Double pump group Variable flow 2 Poles	<b>P22VS</b> <sup>(2)</sup>	○	○	○	○	○	○	○	○
Double pump group Variable flow 2 Poles + tank	<b>P22VS+MV</b> <sup>(2)</sup>	○	○	○	○	○	○	○	○
Higher available pressure double pump group	<b>P2H</b>	○	○	○	○	○	○	○	○
Higher available pressure double pump group + tank	<b>P2H+MV</b>	○	○	○	○	○	○	○	○
Rubber-type vibration dampers	<b>PA</b>	○	○	○	○	○	○	○	○
Spring-type vibration dampers	<b>PM</b>	○	○	○	○	○	○	○	○
Remote display	<b>PQ</b>	○	○	○	○	○	○	○	○
In-line twin pump group (only one working)	<b>PT</b>	○	○	○	○	○	○	○	○
In-line twin pump group (only one working) + tank	<b>PT+MV</b>	○	○	○	○	○	○	○	○
In-line twin pump group Variable flow	<b>PTVS</b>	○	○	○	○	○	○	○	○
In-line twin pump group Variable flow + tank	<b>PTVS+MV</b>	○	○	○	○	○	○	○	○
Anti-freeze heater on evaporator	<b>RA</b>	○	○	○	○	○	○	○	○
Shut-off valve on compressors discharge side	<b>RD</b>	○	○	○	○	○	○	○	○
Shut-off valve on compressors suction side	<b>RH</b>	○	○	○	○	○	○	○	○
Compressor overload relays	<b>RL</b>	○	○	○	○	○	○	○	○
Prepainted fins coil	<b>RM</b>	○	○	○	○	○	○	○	○
Partial heat recovery	<b>RP</b>	○	○	○	○	○	○	○	○
Copper/Copper coil	<b>RR</b>	○	○	○	○	○	○	○	○
Electronic thermostatic valve	<b>TE</b>	●	●	●	●	●	●	●	●
Voltmeter	<b>V</b>	○	○	○	○	○	○	○	○
Brine Version	<b>VB</b>	○	○	○	○	○	○	○	○
Solenoid valve	<b>VS</b>	○	○	○	○	○	○	○	○

(1) Standard for U versions

(2) 4 poles for U versions (P14 / P24)

● Standard ○ Optional – Not available

# LZT

## HIGH EFFICIENCY AIR TO WATER HEAT PUMPS EQUIPPED WITH E.V.I. COMPRESSORS AND AXIAL FANS

Heating power from 23 kW to 218 kW

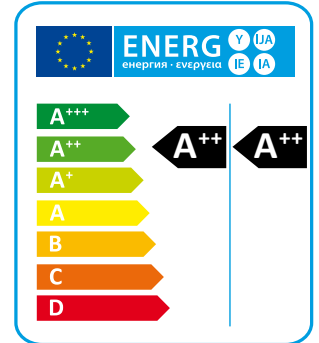

The LZT series of high efficiency heat pumps has been specifically designed for use with radiant floor heating systems or those applications where it is necessary to have maximum efficiency when heating.

They have been optimized on heating mode, are able to produce water up to 65°C and can operate down to -20°C ambient temperature.

All versions are supplied with reverse cycle valve used for winter defrost; the HH version is suitable for use in those countries that have support schemes for use of heat pump technology for heating. The RV versions are also able to produce cold water. The HH heating only versions is factory set and locked to operate only in heating mode whilst.

The noise in XL and NN versions is extremely low thanks to the use of a special floating vibration damping system which allows a noise reduction of about 6-8 dB(A).

### VERSIONS

- HH** Heating only.
- RV** Reversible heating/cooling.
- SA** Standard efficiency, AC fans.
- SE** Standard efficiency, EC fans.
- HA** High efficiency, AC fans.
- HE** High efficiency, EC fans.
- LS** Low noise.
- XL** Super low noise.
- NN** Ultra low noise.
- P2U** 2 pipe systems without domestic hot water production.
- P2S** 2 pipe systems with domestic hot water production by external 3 way valve.

Heating only version (HH)

SA/LS/HH - P2S/P2U		242	292	432	492	592	752	852
Heating capacity (EN14511) <sup>(1)</sup>	kW	23,7	28,3	42,1	50,9	55,0	67,8	74,5
Total input power (EN14511) <sup>(1)</sup>	kW	5,5	6,8	10,3	12,3	13,4	16,3	18,3
COP (EN14511) <sup>(1)</sup>	W/W	4,31	4,16	4,11	4,14	4,12	4,16	4,07
Energy Class in low temperature <sup>(2)</sup>		A+	A+	A+	A+	A+	A+	A+
SCOP low temperature <sup>(2)</sup>	kWh/kWh	3,75	3,77	3,39	3,33	3,49	3,70	3,62
η <sub>s,h</sub> low temperature <sup>(2)</sup>	%	147	148	133	130	137	145	142
Energy Class in medium temperature <sup>(2)</sup>		A+	A+	A+	A+	A+	A+	A+
SCOP medium temperature <sup>(2)</sup>	kWh/kWh	3,04	3,07	2,89	2,87	2,93	3,06	3,03
η <sub>s,h</sub> medium temperature <sup>(2)</sup>	%	119	120	112	112	114	119	118
Sound power <sup>(3)</sup>	dB (A)	78	78	79	80	80	80	80
Sound pressure <sup>(4)</sup>	dB (A)	46	46	47	48	48	48	48
SE/LS/HH - P2S/P2U		242	292	432	492	592	752	852
Heating capacity (EN14511) <sup>(1)</sup>	kW	23,7	28,3	42,1	50,5	55,2	67,8	74,7
Total input power (EN14511) <sup>(1)</sup>	kW	5,3	6,7	9,9	12,8	13,8	16,1	18,2
COP (EN14511) <sup>(1)</sup>	W/W	4,47	4,22	4,25	3,95	4,00	4,21	4,10
Energy Class in low temperature <sup>(2)</sup>		A++	A++	A+	A+	A+	A+	A+
SCOP low temperature <sup>(2)</sup>	kWh/kWh	3,95	3,87	3,58	3,45	3,59	3,79	3,68
η <sub>s,h</sub> low temperature <sup>(2)</sup>	%	155	152	140	135	141	149	144
Energy Class in medium temperature <sup>(2)</sup>		A+	A+	A+	A+	A+	A+	A+
SCOP medium temperature <sup>(2)</sup>	kWh/kWh	3,17	3,13	3,02	2,99	3,02	3,13	3,10
η <sub>s,h</sub> medium temperature <sup>(2)</sup>	%	124	122	118	116	118	122	121
Sound power <sup>(3)</sup>	dB (A)	78	78	79	80	80	80	80
Sound pressure <sup>(4)</sup>	dB (A)	46	46	47	48	48	48	48
Power supply	V/Ph/Hz	400/3+N/50	400/3+N/50	400/3/50	400/3/50	400/3/50	400/3/50	400/3/50
Compressors / Circuits	n° / n°	2 / 1	2 / 1	2 / 1	2 / 1	2 / 1	2 / 1	2 / 1
Fans	n°	1	1	2	2	2	2	2
Refrigerant		R410A	R410A	R410A	R410A	R410A	R410A	R410A
Refrigerant charge	kg	10,0	10,0	10,0	12,0	12,0	18,0	19,0
Global warming potential (GWP)		2088	2088	2088	2088	2088	2088	2088
Equivalent CO <sub>2</sub> charge	t	20,88	20,88	20,88	25,05	25,05	37,58	39,67
Water tank volume	l	100	100	100	100	100	300	300

SA/LS/HH - P2S/P2U		1002	1202	1454	1654	1854	2154
Heating capacity (EN14511) <sup>(1)</sup>	kW	88,5	102,5	145,3	162,9	180,2	205,4
Total input power (EN14511) <sup>(1)</sup>	kW	21,1	25,8	35,2	41,2	43,6	52,9
COP (EN14511) <sup>(1)</sup>	W/W	4,21	3,98	4,13	3,96	4,13	3,88
Energy Class in low temperature <sup>(2)</sup>		A+	A+	A+	A+	A+	A+
SCOP low temperature <sup>(2)</sup>	kWh/kWh	3,61	3,60	3,44	3,42	3,43	3,42
η <sub>s,h</sub> low temperature <sup>(2)</sup>	%	141	141	135	134	134	134
Energy Class in medium temperature <sup>(2)</sup>		A+	A+	A+	A+	A+	A+
SCOP medium temperature <sup>(2)</sup>	kWh/kWh	3,01	2,99	2,85	2,90	2,92	2,95
η <sub>s,h</sub> medium temperature <sup>(2)</sup>	%	117	117	111	113	114	115
Sound power <sup>(3)</sup>	dB (A)	80	80	87	87	88	89
Sound pressure <sup>(4)</sup>	dB (A)	48	48	55	55	56	57
SE/LS/HH - P2S/P2U		1002	1202	1454	1654	1854	2154
Heating capacity (EN14511) <sup>(1)</sup>	kW	88,2	102,5	146,0	164,3	181,3	208,1
Total input power (EN14511) <sup>(1)</sup>	kW	20,7	25,4	33,6	39,03	41,91	50,66
COP (EN14511) <sup>(1)</sup>	W/W	4,26	4,03	4,35	4,21	4,33	4,11
Energy Class in low temperature <sup>(2)</sup>		A+	A+	A+	A+	A+	A+
SCOP low temperature <sup>(2)</sup>	kWh/kWh	3,69	3,70	3,63	3,57	3,69	3,63
η <sub>s,h</sub> low temperature <sup>(2)</sup>	%	145	145	142	140	145	142
Energy Class in medium temperature <sup>(2)</sup>		A+	A+	A+	A+	A+	A+
SCOP medium temperature <sup>(2)</sup>	kWh/kWh	3,10	3,06	2,95	2,99	3,06	3,07
η <sub>s,h</sub> medium temperature <sup>(2)</sup>	%	121	120	115	117	120	120
Sound power <sup>(3)</sup>	dB (A)	80	80	86	87	88	89
Sound pressure <sup>(4)</sup>	dB (A)	48	48	54	55	56	57
Power supply	V/Ph/Hz	400/3/50	400/3/50	400/3/50	400/3/50	400/3/50	400/3/50
Compressors / Circuits	n° / n°	2 / 1	2 / 1	4/2	4/2	4/2	4/2
Fans	n°	3	4	4	4	4	4
Refrigerant		R410A	R410A	R410A	R410A	R410A	R410A
Refrigerant charge	kg	23,0	23,0	45,0	45,0	50,0	50,0
Global warming potential (GWP)		2088	2088	2088	2088	2088	2088
Equivalent CO <sub>2</sub> charge	t	48,02	48,02	93,96	93,96	104,40	104,40
Water tank volume	l	300	300	500	500	500	500

Performances are referred to the following conditions:

(1) Heating: Ambient temperature 7°C DB, 6°C WB, water temperature 30/35°C.

(2) Average conditions, variable - Reg EU 811/2013

(3) Sound power level in accordance with ISO 3744.

(4) Sound pressure level at 10 mt from the unit in free field conditions in accordance with ISO 3744.

Heating only version (HH)

L7

HA/LS/HH - P2S/P2U		242	292	432	492	602	752	852
Heating capacity (EN14511) <sup>(1)</sup>	kW	23,8	29,4	41,6	51,2	58,0	66,7	80,8
Total input power (EN14511) <sup>(1)</sup>	kW	5,3	6,8	9,7	12,4	13,0	15,6	19,6
COP (EN14511) <sup>(1)</sup>	W/W	4,51	4,31	4,29	4,12	4,45	4,29	4,13
Energy Class in low temperature <sup>(2)</sup>		A++	A++	A+	A+	A++	A++	A+
SCOP low temperature <sup>(2)</sup>	kWh/kWh	3,96	3,89	3,63	3,553	3,94	3,95	3,76
η <sub>s,h</sub> low temperature <sup>(2)</sup>	%	155	153	142	139	155	155	147
Energy Class in medium temperature <sup>(2)</sup>		A+	A+	A+	A+	A++	A+	A+
SCOP medium temperature <sup>(2)</sup>	kWh/kWh	3,18	3,15	2,99	2,98	3,21	3,16	3,01
η <sub>s,h</sub> medium temperature <sup>(2)</sup>	%	124	123	117	116	126	123	117
Sound power <sup>(3)</sup>	dB (A)	78	78	78	79	80	80	83
Sound pressure <sup>(4)</sup>	dB (A)	46	46	46	47	48	48	51
HE/LS/HH - P2S/P2U		242	292	432	492	602	752	852
Heating capacity (EN14511) <sup>(1)</sup>	kW	24,0	29,5	41,8	50,3	58,3	66,9	81,3
Total input power (EN14511) <sup>(1)</sup>	kW	5,2	6,7	9,5	12,2	12,8	15,3	18,9
COP (EN14511) <sup>(1)</sup>	W/W	4,61	4,38	4,40	4,12	4,56	4,37	4,31
Energy Class in low temperature <sup>(2)</sup>		A++	A++	A++	A++	A++	A++	A++
SCOP low temperature <sup>(2)</sup>	kWh/kWh	4,10	3,96	3,87	3,83	4,08	4,06	3,83
η <sub>s,h</sub> low temperature <sup>(2)</sup>	%	161	156	152	150	160	159	150
Energy Class in medium temperature <sup>(2)</sup>		A++	A++	A+	A+	A++	A++	A+
SCOP medium temperature <sup>(2)</sup>	kWh/kWh	3,25	3,21	3,12	3,15	3,29	3,23	3,07
η <sub>s,h</sub> medium temperature <sup>(2)</sup>	%	127	125	122	123	129	126	120
Sound power <sup>(3)</sup>	dB (A)	78	78	78	79	80	80	83
Sound pressure <sup>(4)</sup>	dB (A)	46	46	46	47	48	48	51
Power supply	V/Ph/Hz	400/3+N/50			400/3/50			
Compressors / Circuits	n° / n°	2 / 1	2 / 1	2 / 1	2 / 1	2 / 1	2 / 1	2 / 1
Fans	n°	1	1	2	2	2	2	2
Refrigerant		R410A	R410A	R410A	R410A	R410A	R410A	R410A
Refrigerant charge	kg	10,0	10,0	14,5	12,0	18,0	23,0	23,0
Global warming potential (GWP)		2088	2088	2088	2088	2088	2088	2088
Equivalent CO <sub>2</sub> charge	t	20,88	20,88	30,27	25,05	37,58	48,02	48,02
Water tank volume	l	100	100	100	100	300	300	300

HA/LS/HH - P2S/P2U		1002	1202	1454	1654	1854	2154
Heating capacity (EN14511) <sup>(1)</sup>	kW	88,4	102,5	145,6	163,7	181,9	210,2
Total input power (EN14511) <sup>(1)</sup>	kW	21,4	25,3	35,2	40,7	43,8	52,2
COP (EN14511) <sup>(1)</sup>	W/W	4,13	4,05	4,14	4,02	4,16	4,02
Energy Class in low temperature <sup>(2)</sup>		A+	A+	A+	A+	A+	A+
SCOP low temperature <sup>(2)</sup>	kWh/kWh	3,80	3,78	3,74	3,65	3,79	3,78
η <sub>s,h</sub> low temperature <sup>(2)</sup>	%	149	148	147	143	149	148
Energy Class in medium temperature <sup>(2)</sup>		A+	A+	A+	A+	A+	A+
SCOP medium temperature <sup>(2)</sup>	kWh/kWh	3,05	3,06	3,05	3,03	3,12	3,16
η <sub>s,h</sub> medium temperature <sup>(2)</sup>	%	119	120	119	118	122	123
Sound power <sup>(3)</sup>	dB (A)	83	83	84	85	85	85
Sound pressure <sup>(4)</sup>	dB (A)	51	51	52	53	53	53
HE/LS/HH - P2S/P2U		1002	1202	1454	1654	1854	2154
Heating capacity (EN14511) <sup>(1)</sup>	kW	88,5	102,7	145,2	163,2	181,3	209,6
Total input power (EN14511) <sup>(1)</sup>	kW	20,6	24,6	33,4	38,9	41,9	50,5
COP (EN14511) <sup>(1)</sup>	W/W	4,31	4,17	4,35	4,19	4,33	4,15
Energy Class in low temperature <sup>(2)</sup>		A++	A++	A++	A++	A++	A++
SCOP low temperature <sup>(2)</sup>	kWh/kWh	3,85	3,84	3,88	3,88	3,89	3,89
η <sub>s,h</sub> low temperature <sup>(2)</sup>	%	151	151	152	152	153	153
Energy Class in medium temperature <sup>(2)</sup>		A+	A+	A+	A+	A+	A+
SCOP medium temperature <sup>(2)</sup>	kWh/kWh	3,14	3,13	3,10	3,15	3,17	3,19
η <sub>s,h</sub> medium temperature <sup>(2)</sup>	%	123	122	121	123	124	124
Sound power <sup>(3)</sup>	dB (A)	83	83	84	85	85	85
Sound pressure <sup>(4)</sup>	dB (A)	51	51	52	53	53	53
Power supply	V/Ph/Hz	400/3/50					
Compressors / Circuits	n° / n°	2 / 1	2 / 1	4/2	4/2	4/2	4/2
Fans	n°	2	2	3	3	3	3
Refrigerant		R410A	R410A	R410A	R410A	R410A	R410A
Refrigerant charge	kg	27,0	27,0	45,0	45,0	50,0	50,0
Global warming potential (GWP)		2088	2088	2088	2088	2088	2088
Equivalent CO <sub>2</sub> charge	t	56,37	56,37	93,96	93,96	104,40	104,40
Water tank volume	l	300	300	500	500	500	500

Performances are referred to the following conditions:

(1) Heating: Ambient temperature 7°C DB, 6°C WB, water temperature 30/35°C.

(2) Average conditions, variable - Reg EU 811/2013

(3) Sound power level in accordance with ISO 3744.

(4) Sound pressure level at 10 mt from the unit in free field conditions in accordance with ISO 3744.

Heating only version (HH)

<b>HA/XL/HH - P2S/P2U</b>		<b>252</b>	<b>302</b>	<b>432</b>	<b>492</b>	<b>602</b>	<b>752</b>	<b>852</b>
Heating capacity (EN14511) <sup>(1)</sup>	kW	24,0	29,6	41,1	48,9	57,4	65,5	80,1
Total input power (EN14511) <sup>(1)</sup>	kW	5,5	7,0	9,5	12,1	12,9	15,2	18,4
COP (EN14511) <sup>(1)</sup>	W/W	4,40	4,24	4,35	4,04	4,46	4,31	4,35
Energy Class in low temperature <sup>(2)</sup>		A++	A++	A++	A++	A++	A++	A++
SCOP low temperature <sup>(2)</sup>	kWh/kWh	3,83	3,84	3,84	3,83	4,03	4,01	3,83
η <sub>s,h</sub> low temperature <sup>(2)</sup>	%	150	151	151	150	158	158	150
Energy Class in medium temperature <sup>(2)</sup>		A+	A+	A+	A+	A++	A+	A+
SCOP medium temperature <sup>(2)</sup>	kWh/kWh	3,05	3,13	3,11	3,14	3,27	3,20	3,13
η <sub>s,h</sub> medium temperature <sup>(2)</sup>	%	119	122	121	122	128	125	122
Sound power <sup>(3)</sup>	dB (A)	72	72	73	74	74	74	74
Sound pressure <sup>(4)</sup>	dB (A)	40	40	41	42	42	42	42
<b>HE/XL/HH - P2S/P2U</b>		<b>252</b>	<b>302</b>	<b>432</b>	<b>492</b>	<b>602</b>	<b>752</b>	<b>852</b>
Heating capacity (EN14511) <sup>(1)</sup>	kW	24,0	30,0	41,2	49,2	57,4	65,6	79,9
Total input power (EN14511) <sup>(1)</sup>	kW	5,2	6,8	9,2	11,8	12,6	15,1	17,8
COP (EN14511) <sup>(1)</sup>	W/W	4,64	4,39	4,49	4,16	4,57	4,35	4,49
Energy Class in low temperature <sup>(2)</sup>		A++	A++	A++	A++	A++	A++	A++
SCOP low temperature <sup>(2)</sup>	kWh/kWh	4,10	3,87	4,00	3,84	4,21	4,16	4,04
η <sub>s,h</sub> low temperature <sup>(2)</sup>	%	161	152	157	151	165	163	159
Energy Class in medium temperature <sup>(2)</sup>		A++	A+	A++	A++	A++	A++	A++
SCOP medium temperature <sup>(2)</sup>	kWh/kWh	3,24	3,14	3,24	3,16	3,38	3,29	3,26
η <sub>s,h</sub> medium temperature <sup>(2)</sup>	%	127	123	127	123	132	129	127
Sound power <sup>(3)</sup>	dB (A)	71	72	73	74	73	73	74
Sound pressure <sup>(4)</sup>	dB (A)	39	40	41	42	41	41	42
Power supply	V/Ph/Hz	400/3+N/50	400/3+N/50	400/3/50	400/3/50	400/3/50	400/3/50	400/3/50
Compressors / Circuits	n° / n°	2 / 1	2 / 1	2 / 1	2 / 1	2 / 1	2 / 1	2 / 1
Fans	n°	2	2	2	2	2	2	2
Refrigerant		R410A	R410A	R410A	R410A	R410A	R410A	R410A
Refrigerant charge	kg	10,0	10,0	14,5	12,0	18,0	23,0	23,0
Global warming potential (GWP)		2088	2088	2088	2088	2088	2088	2088
Equivalent CO <sub>2</sub> charge	t	20,88	20,88	30,27	25,05	37,58	48,02	48,02
Water tank volume	l	100	100	100	100	300	300	300

<b>HA/XL/HH - P2S/P2U</b>		<b>1002</b>	<b>1202</b>	<b>1454</b>	<b>1654</b>	<b>1854</b>	<b>2154</b>
Heating capacity (EN14511) <sup>(1)</sup>	kW	87,3	100,7	147,8	166,9	187,4	218,2
Total input power (EN14511) <sup>(1)</sup>	kW	20,0	23,8	33,5	38,7	43,1	51,3
COP (EN14511) <sup>(1)</sup>	W/W	4,37	4,23	4,41	4,31	4,35	4,25
Energy Class in low temperature <sup>(2)</sup>		A++	A++	A++	A++	A++	A++
SCOP low temperature <sup>(2)</sup>	kWh/kWh	3,91	3,84	3,93	3,90	3,88	3,88
η <sub>s,h</sub> low temperature <sup>(2)</sup>	%	153	151	154	153	152	152
Energy Class in medium temperature <sup>(2)</sup>		A++	A+	A+	A+	A+	A+
SCOP medium temperature <sup>(2)</sup>	kWh/kWh	3,21	3,18	3,16	3,17	3,10	3,13
η <sub>s,h</sub> medium temperature <sup>(2)</sup>	%	126	124	123	124	121	122
Sound power <sup>(3)</sup>	dB (A)	75	75	79	79	80	80
Sound pressure <sup>(4)</sup>	dB (A)	43	43	47	47	48	48
<b>HE/XL/HH - P2S/P2U</b>		<b>1002</b>	<b>1202</b>	<b>1454</b>	<b>1654</b>	<b>1854</b>	<b>2154</b>
Heating capacity (EN14511) <sup>(1)</sup>	kW	87,2	100,7	147,6	166,6	187,6	218,2
Total input power (EN14511) <sup>(1)</sup>	kW	19,4	23,5	32,3	37,6	41,2	49,5
COP (EN14511) <sup>(1)</sup>	W/W	4,49	4,29	4,57	4,43	4,55	4,41
Energy Class in low temperature <sup>(2)</sup>		A++	A++	A++	A++	A++	A++
SCOP low temperature <sup>(2)</sup>	kWh/kWh	4,06	3,93	4,10	4,00	3,94	3,92
η <sub>s,h</sub> low temperature <sup>(2)</sup>	%	160	154	161	157	154	154
Energy Class in medium temperature <sup>(2)</sup>		A++	A++	A++	A++	A++	A++
SCOP medium temperature <sup>(2)</sup>	kWh/kWh	3,33	3,25	3,28	3,29	3,28	3,28
η <sub>s,h</sub> medium temperature <sup>(2)</sup>	%	130	127	128	129	128	128
Sound power <sup>(3)</sup>	dB (A)	75	75	79	79	80	80
Sound pressure <sup>(4)</sup>	dB (A)	43	43	47	47	48	48
Power supply	V/Ph/Hz	400/3/50	400/3/50	400/3/50	400/3/50	400/3/50	400/3/50
Compressors / Circuits	n° / n°	2 / 1	2 / 1	4/2	4/2	4/2	4/2
Fans	n°	2	2	4	4	6	6
Refrigerant		R410A	R410A	R410A	R410A	R410A	R410A
Refrigerant charge	kg	27,0	27,0	50,0	50,0	55,0	55,0
Global warming potential (GWP)		2088	2088	2088	2088	2088	2088
Equivalent CO <sub>2</sub> charge	t	56,37	56,37	104,40	104,40	114,84	114,84
Water tank volume	l	300	300	500	500	500	500

Performances are referred to the following conditions:

(1) Heating: Ambient temperature 7°C DB, 6°C WB, water temperature 30/35°C.

(2) Average conditions, variable - Reg EU 811/2013

(3) Sound power level in accordance with ISO 3744.

(4) Sound pressure level at 10 mt from the unit in free field conditions in accordance with ISO 3744.

Heating only version (HH)

HE/NN/HH - P2S/P2U		252	312	452	502	602	752	852
Heating capacity (EN14511) <sup>(1)</sup>	kW	23,4	30,5	41,1	54,2	60,7	70,4	79,5
Total input power (EN14511) <sup>(1)</sup>	kW	5,0	6,4	8,8	11,7	12,4	14,7	17,41
COP (EN14511) <sup>(1)</sup>	W/W	4,69	4,75	4,69	4,64	4,89	4,78	4,56
Energy Class in low temperature <sup>(2)</sup>		A++	A++	A++	A++	A++	A++	A++
SCOP low temperature <sup>(2)</sup>	kWh/kWh	4,30	4,35	4,23	4,10	4,37	4,40	4,22
$\eta_{s,h}$ low temperature <sup>(2)</sup>	%	169	171	166	161	172	173	166
Energy Class in medium temperature <sup>(2)</sup>		A++	A++	A++	A++	A++	A++	A++
SCOP medium temperature <sup>(2)</sup>	kWh/kWh	3,34	3,48	3,42	3,34	3,47	3,45	3,38
$\eta_{s,h}$ medium temperature <sup>(2)</sup>	%	131	136	134	131	136	135	132
Sound power <sup>(3)</sup>	dB (A)	68	69	71	71	71	72	72
Sound pressure <sup>(4)</sup>	dB (A)	36	37	39	39	39	40	40
Power supply	V/Ph/Hz	400/3+N/50	400/3/50	400/3/50	400/3/50	400/3/50	400/3/50	400/3/50
Compressors / Circuits	n° / n°	2 / 1	2 / 1	2 / 1	2 / 1	2 / 1	2 / 1	2 / 1
Fans	n°	2	2	2	2	2	2	2
Refrigerant		R410A	R410A	R410A	R410A	R410A	R410A	R410A
Refrigerant charge	kg	10,0	10,0	18,0	23,0	18,0	23,0	23,0
Global warming potential (GWP)		2088,0	2088	2088	2088	2088	2088	2088
Equivalent CO <sub>2</sub> charge	t	20,88	20,88	37,58	48,02	37,58	48,02	48,02

HE/NN/HH - P2S/P2U		1002	1202	1454	1654	1854	2154
Heating capacity (EN14511) <sup>(1)</sup>	kW	90,3	104,9	146,7	165,1	184,7	214,0
Total input power (EN14511) <sup>(1)</sup>	kW	18,6	22,1	31,5	36,6	40,0	48,0
COP (EN14511) <sup>(1)</sup>	W/W	4,87	4,75	4,66	4,51	4,62	4,46
Energy Class in low temperature <sup>(2)</sup>		A++	A++	A++	A++	A++	A++
SCOP low temperature <sup>(2)</sup>	kWh/kWh	4,42	4,31	4,31	4,15	4,23	4,12
$\eta_{s,h}$ low temperature <sup>(2)</sup>	%	174	169	169	163	166	162
Energy Class in medium temperature <sup>(2)</sup>		A++	A++	A++	A++	A++	A++
SCOP medium temperature <sup>(2)</sup>	kWh/kWh	3,52	3,50	3,41	3,40	3,47	3,42
$\eta_{s,h}$ medium temperature <sup>(2)</sup>	%	138	137	134	133	136	134
Sound power <sup>(3)</sup>	dB (A)	72	72	74	74	75	75
Sound pressure <sup>(4)</sup>	dB (A)	40	40	42	42	43	43
Power supply	V/Ph/Hz	400/3/50	400/3/50	400/3/50	400/3/50	400/3/50	400/3/50
Compressors / Circuits	n° / n°	2 / 1	2 / 1	4/2	4/2	4/2	4/2
Fans	n°	3	3	4	4	6	6
Refrigerant		R410A	R410A	R410A	R410A	R410A	R410A
Refrigerant charge	kg	36,0	36,0	50,0	50,0	55,0	55,0
Global warming potential (GWP)		2088	2088	2088	2088	2088	2088
Equivalent CO <sub>2</sub> charge	t	75,16	75,16	104,40	104,40	114,84	114,84

Performances are referred to the following conditions:

(1) Heating: Ambient temperature 7°C DB, 6°C WB, water temperature 30/35°C.

(2) Average conditions, variable - Reg EU 811/2013

(3) Sound power level in accordance with ISO 3744.

(4) Sound pressure level at 10 mt from the unit in free field conditions in accordance with ISO 3744.

Reversible heating/cooling version (RV)

SA/LS/RV - P2S/P2U		242	292	432	492	592	752	852
Heating capacity (EN14511) <sup>(1)</sup>	kW	23,7	28,3	42,1	50,9	55,0	67,8	74,5
Total input power (EN14511) <sup>(1)</sup>	kW	5,5	6,8	10,3	12,3	13,4	16,3	18,3
COP (EN14511) <sup>(1)</sup>	W/W	4,31	4,16	4,11	4,14	4,12	4,16	4,07
Energy Class in low temperature <sup>(2)</sup>		A+	A+	A+	A+	A+	A+	A+
SCOP low temperature <sup>(2)</sup>	kWh/kWh	3,75	3,77	3,39	3,33	3,49	3,70	3,62
η <sub>s,h</sub> low temperature <sup>(2)</sup>	%	147	148	133	130	137	145	142
Energy Class in medium temperature <sup>(2)</sup>		A+	A+	A+	A+	A+	A+	A+
SCOP medium temperature <sup>(2)</sup>	kWh/kWh	3,04	3,07	2,89	2,87	2,93	3,06	3,03
η <sub>s,h</sub> medium temperature <sup>(2)</sup>	%	119	120	112	112	114	119	118
Cooling capacity (EN14511) <sup>(3)</sup>	kW	22,5	29,5	36,4	46,1	53,6	61,6	74,3
Total input power (EN14511) <sup>(3)</sup>	kW	7,1	9,1	12,9	16,4	19,3	22,3	25,5
EER (EN14511) <sup>(3)</sup>	W/W	3,15	3,24	2,82	2,80	2,78	2,76	2,91
Sound power <sup>(4)</sup>	dB (A)	78	78	79	80	80	80	80
Sound pressure <sup>(5)</sup>	dB (A)	46	46	47	48	48	48	48

SE/LS/RV - P2S/P2U		242	292	432	492	592	752	852
Heating capacity (EN14511) <sup>(1)</sup>	kW	23,7	28,3	42,1	50,5	55,2	67,8	74,7
Total input power (EN14511) <sup>(1)</sup>	kW	5,3	6,7	9,9	12,8	13,8	16,1	18,2
COP (EN14511) <sup>(1)</sup>	W/W	4,47	4,22	4,25	3,95	4,00	4,21	4,10
Energy Class in low temperature <sup>(2)</sup>		A++	A++	A+	A+	A+	A+	A+
SCOP low temperature <sup>(2)</sup>	kWh/kWh	3,95	3,87	3,58	3,45	3,59	3,79	3,68
η <sub>s,h</sub> low temperature <sup>(2)</sup>	%	155	152	140	135	141	149	144
Energy Class in medium temperature <sup>(2)</sup>		A+	A+	A+	A+	A+	A+	A+
SCOP medium temperature <sup>(2)</sup>	kWh/kWh	3,17	3,13	3,02	2,99	3,02	3,13	3,10
η <sub>s,h</sub> medium temperature <sup>(2)</sup>	%	124	122	118	116	118	122	121
Cooling capacity (EN14511) <sup>(3)</sup>	kW	22,65	29,92	36,5	46,43	53,75	61,94	74,64
Total input power (EN14511) <sup>(3)</sup>	kW	7,1	9,0	12,8	16,2	19,2	21,9	25,4
EER (EN14511) <sup>(3)</sup>	W/W	3,19	3,32	2,86	2,86	2,81	2,83	2,94
Sound power <sup>(4)</sup>	dB (A)	78	78	79	80	80	80	80
Sound pressure <sup>(5)</sup>	dB (A)	46	46	47	48	48	48	48
Power supply	V/Ph/Hz	400/3+N/50	400/3+N/50	400/3/50	400/3/50	400/3/50	400/3/50	400/3/50
Compressors / Circuits	n° / n°	2 / 1	2 / 1	2 / 1	2 / 1	2 / 1	2 / 1	2 / 1
Fans	n°	1	1	2	2	2	2	2
Refrigerant		R410A	R410A	R410A	R410A	R410A	R410A	R410A
Refrigerant charge	kg	10,0	10,0	10,0	12,0	12,0	18,0	19,0
Global warming potential (GWP)		2088	2088	2088	2088	2088	2088	2088
Equivalent CO <sub>2</sub> charge	t	20,88	20,88	20,88	25,05	25,05	37,58	39,67
Water tank volume	l	100	100	100	100	100	300	300

SA/LS/RV - P2S/P2U		1002	1202	1454	1654	1854	2154
Heating capacity (EN14511) <sup>(1)</sup>	kW	88,5	102,5	145,3	162,9	180,2	205,4
Total input power (EN14511) <sup>(1)</sup>	kW	21,1	25,8	35,2	41,2	43,6	52,9
COP (EN14511) <sup>(1)</sup>	W/W	4,21	3,98	4,13	3,96	4,13	3,88
Energy Class in low temperature <sup>(2)</sup>		A+	A+	A+	A+	A+	A+
SCOP low temperature <sup>(2)</sup>	kWh/kWh	3,61	3,60	3,44	3,42	3,43	3,42
η <sub>s,h</sub> low temperature <sup>(2)</sup>	%	141	141	135	134	134	134
Energy Class in medium temperature <sup>(2)</sup>		A+	A+	A+	A+	A+	A+
SCOP medium temperature <sup>(2)</sup>	kWh/kWh	3,01	2,99	2,85	2,90	2,92	2,95
η <sub>s,h</sub> medium temperature <sup>(2)</sup>	%	117	117	111	113	114	115
Cooling capacity (EN14511) <sup>(3)</sup>	kW	77,9	90,4	125,8	142,0	155,1	177,9
Total input power (EN14511) <sup>(3)</sup>	kW	26,9	32,6	44,1	51,7	55,3	68,6
EER (EN14511) <sup>(3)</sup>	W/W	2,89	2,77	2,85	2,75	2,80	2,59
Sound power <sup>(4)</sup>	dB (A)	80	80	87	87	88	89
Sound pressure <sup>(5)</sup>	dB (A)	48	48	55	55	56	57

SE/LS/RV - P2S/P2U		1002	1202	1454	1654	1854	2154
Heating capacity (EN14511) <sup>(1)</sup>	kW	88,2	102,5	146,0	164,3	181,3	208,1
Total input power (EN14511) <sup>(1)</sup>	kW	20,7	25,4	33,6	39,03	41,91	50,66
COP (EN14511) <sup>(1)</sup>	W/W	4,26	4,03	4,35	4,21	4,33	4,11
Energy Class in low temperature <sup>(2)</sup>		A+	A+	A+	A+	A+	A+
SCOP low temperature <sup>(2)</sup>	kWh/kWh	3,69	3,70	3,63	3,57	3,69	3,63
η <sub>s,h</sub> low temperature <sup>(2)</sup>	%	145	145	142	140	145	142
Energy Class in medium temperature <sup>(2)</sup>		A+	A+	A+	A+	A+	A+
SCOP medium temperature <sup>(2)</sup>	kWh/kWh	3,10	3,06	2,95	2,99	3,06	3,07
η <sub>s,h</sub> medium temperature <sup>(2)</sup>	%	121	120	115	117	120	120
Cooling capacity (EN14511) <sup>(3)</sup>	kW	78,1	90,9	126,4	143,1	156,3	179,3
Total input power (EN14511) <sup>(3)</sup>	kW	25,0	32,1	41,7	49,5	53,5	66,1
EER (EN14511) <sup>(3)</sup>	W/W	3,13	2,83	3,03	2,89	2,92	2,71
Sound power <sup>(4)</sup>	dB (A)	80	80	86	87	88	89
Sound pressure <sup>(5)</sup>	dB (A)	48	48	54	55	56	57
Power supply	V/Ph/Hz	400/3/50	400/3/50	400/3/50	400/3/50	400/3/50	400/3/50
Compressors / Circuits	n° / n°	2 / 1	2 / 1	4/2	4/2	4/2	4/2
Fans	n°	3	4	4	4	4	4
Refrigerant		R410A	R410A	R410A	R410A	R410A	R410A
Refrigerant charge	kg	23,0	23,0	45,0	45,0	50,0	50,0
Global warming potential (GWP)		2088	2088	2088	2088	2088	2088
Equivalent CO <sub>2</sub> charge	t	48,02	48,02	93,96	93,96	104,40	104,40
Water tank volume	l	300	300	500	500	500	500

Performances are referred to the following conditions:

- (1) Heating: Ambient temperature 7°C DB, 6°C WB, water temperature 30/35°C.
- (2) Average conditions, variable - Reg EU 811/2013

- (3) Cooling: ambient air temperature 35°C, evaporator water temperature in/out 12/7 °C.
- (4) Sound power level in accordance with ISO 3744.
- (5) Sound pressure level at 10 mt from the unit in free field conditions in accordance with ISO 3744.

Reversible heating/cooling version (RV)

L71

HA/LS/RV - P2S/P2U		242	292	432	492	602	752	852
Heating capacity (EN14511) <sup>(1)</sup>	kW	23,8	29,4	41,6	51,2	58,0	66,7	80,8
Total input power (EN14511) <sup>(1)</sup>	kW	5,3	6,8	9,7	12,4	13,0	15,6	19,6
COP (EN14511) <sup>(1)</sup>	W/W	4,51	4,31	4,29	4,12	4,45	4,29	4,13
Energy Class in low temperature <sup>(2)</sup>		A++	A++	A+	A+	A++	A++	A+
SCOP low temperature <sup>(2)</sup>	kWh/kWh	3,96	3,89	3,63	3,55	3,94	3,95	3,76
η <sub>s,h</sub> low temperature <sup>(2)</sup>	%	155	153	142	139	155	155	147
Energy Class in medium temperature <sup>(2)</sup>		A+	A+	A+	A+	A++	A+	A+
SCOP medium temperature <sup>(2)</sup>	kWh/kWh	3,18	3,15	2,99	2,98	3,21	3,16	3,01
η <sub>s,h</sub> medium temperature <sup>(2)</sup>	%	124	123	117	116	126	123	117
Cooling capacity (EN14511) <sup>(3)</sup>	kW	22,9	30,1	37,5	46,7	52,8	62,5	71,6
Total input power (EN14511) <sup>(3)</sup>	kW	7,0	9,0	12,7	16,1	18,1	21,6	24,6
EER (EN14511) <sup>(3)</sup>	W/W	3,25	3,36	2,97	2,90	2,91	2,89	2,91
Sound power <sup>(4)</sup>	dB (A)	78	78	78	79	80	80	83
Sound pressure <sup>(5)</sup>	dB (A)	46	46	46	47	48	48	51
HE/LS/RV - P2S/P2U		242	292	432	492	602	752	852
Heating capacity (EN14511) <sup>(1)</sup>	kW	24,0	29,5	41,8	50,3	58,3	66,9	81,3
Total input power (EN14511) <sup>(1)</sup>	kW	5,2	6,7	9,5	12,2	12,8	15,3	18,9
COP (EN14511) <sup>(1)</sup>	W/W	4,61	4,38	4,40	4,12	4,56	4,37	4,31
Energy Class in low temperature <sup>(2)</sup>		A++	A++	A++	A++	A++	A++	A++
SCOP low temperature <sup>(2)</sup>	kWh/kWh	4,10	3,96	3,87	3,83	4,08	4,06	3,83
η <sub>s,h</sub> low temperature <sup>(2)</sup>	%	161	156	152	150	160	159	150
Energy Class in medium temperature <sup>(2)</sup>		A++	A++	A+	A+	A++	A++	A+
SCOP medium temperature <sup>(2)</sup>	kWh/kWh	3,25	3,21	3,12	3,15	3,29	3,23	3,07
η <sub>s,h</sub> medium temperature <sup>(2)</sup>	%	127	125	122	123	129	126	120
Cooling capacity (EN14511) <sup>(3)</sup>	kW	22,9	30,2	37,5	45,6	52,9	62,5	71,6
Total input power (EN14511) <sup>(3)</sup>	kW	7,0	8,8	12,7	16,7	17,9	21,3	24,4
EER (EN14511) <sup>(3)</sup>	W/W	3,27	3,42	2,96	2,73	2,95	2,64	2,94
Sound power <sup>(4)</sup>	dB (A)	78	78	78	79	80	80	83
Sound pressure <sup>(5)</sup>	dB (A)	46	46	46	47	48	48	51
Power supply	V/Ph/Hz	400/3+N/50	400/3+N/50	400/3/50	400/3/50	400/3/50	400/3/50	400/3/50
Compressors / Circuits	n° / n°	2 / 1	2 / 1	2 / 1	2 / 1	2 / 1	2 / 1	2 / 1
Fans	n°	1	1	2	2	2	2	2
Refrigerant		R410A	R410A	R410A	R410A	R410A	R410A	R410A
Refrigerant charge	kg	10,0	10,0	14,5	12,0	18,0	23,0	23,0
Global warming potential (GWP)		2088	2088	2088	2088	2088	2088	2088
Equivalent CO <sub>2</sub> charge	t	20,88	20,88	30,27	25,05	37,58	48,02	48,02
Water tank volume	l	100	100	100	100	300	300	300
HA/LS/RV - P2S/P2U		1002	1202	1454	1654	1854	2154	
Heating capacity (EN14511) <sup>(1)</sup>	kW	88,4	102,5	145,6	163,7	181,9	210,2	
Total input power (EN14511) <sup>(1)</sup>	kW	21,4	25,3	35,2	40,7	43,8	52,2	
COP (EN14511) <sup>(1)</sup>	W/W	4,13	4,05	4,14	4,02	4,16	4,02	
Energy Class in low temperature <sup>(2)</sup>		A+	A+	A+	A+	A+	A+	
SCOP low temperature <sup>(2)</sup>	kWh/kWh	3,80	3,78	3,74	3,65	3,79	3,78	
η <sub>s,h</sub> low temperature <sup>(2)</sup>	%	149	148	147	143	149	148	
Energy Class in medium temperature <sup>(2)</sup>		A+	A+	A+	A+	A+	A+	
SCOP medium temperature <sup>(2)</sup>	kWh/kWh	3,05	3,06	3,05	3,03	3,12	3,16	
η <sub>s,h</sub> medium temperature <sup>(2)</sup>	%	119	120	119	118	122	123	
Cooling capacity (EN14511) <sup>(3)</sup>	kW	78,1	90,2	127,4	143,5	157,8	180,9	
Total input power (EN14511) <sup>(3)</sup>	kW	26,6	32,2	42,4	50,8	53,6	66,5	
EER (EN14511) <sup>(3)</sup>	W/W	2,94	2,80	3,01	2,82	2,94	2,72	
Sound power <sup>(4)</sup>	dB (A)	83	83	84	85	85	85	
Sound pressure <sup>(5)</sup>	dB (A)	51	51	52	53	53	53	
HE/LS/RV - P2S/P2U		1002	1202	1454	1654	1854	2154	
Heating capacity (EN14511) <sup>(1)</sup>	kW	88,5	102,7	145,2	163,2	181,3	209,6	
Total input power (EN14511) <sup>(1)</sup>	kW	20,6	24,6	33,4	38,9	41,9	50,5	
COP (EN14511) <sup>(1)</sup>	W/W	4,31	4,17	4,35	4,19	4,33	4,15	
Energy Class in low temperature <sup>(2)</sup>		A++	A++	A++	A++	A++	A++	
SCOP low temperature <sup>(2)</sup>	kWh/kWh	3,85	3,84	3,88	3,88	3,89	3,89	
η <sub>s,h</sub> low temperature <sup>(2)</sup>	%	151	151	152	152	153	153	
Energy Class in medium temperature <sup>(2)</sup>		A+	A+	A+	A+	A+	A+	
SCOP medium temperature <sup>(2)</sup>	kWh/kWh	3,14	3,13	3,10	3,15	3,17	3,19	
η <sub>s,h</sub> medium temperature <sup>(2)</sup>	%	123	122	121	123	124	124	
Cooling capacity (EN14511) <sup>(3)</sup>	kW	78,2	90,8	126,8	142,8	157,0	180,1	
Total input power (EN14511) <sup>(3)</sup>	kW	26,1	31,3	42,0	50,5	53,4	66,2	
EER (EN14511) <sup>(3)</sup>	W/W	3,00	2,90	3,02	2,83	2,94	2,72	
Sound power <sup>(4)</sup>	dB (A)	83	83	84	85	85	85	
Sound pressure <sup>(5)</sup>	dB (A)	51	51	52	53	53	53	
Power supply	V/Ph/Hz	400/3/50	400/3/50	400/3/50	400/3/50	400/3/50	400/3/50	
Compressors / Circuits	n° / n°	2 / 1	2 / 1	4/2	4/2	4/2	4/2	
Fans	n°	2	2	3	3	3	3	
Refrigerant		R410A	R410A	R410A	R410A	R410A	R410A	
Refrigerant charge	kg	27,0	27,0	45,0	45,0	50,0	50,0	
Global warming potential (GWP)		2088	2088	2088	2088	2088	2088	
Equivalent CO <sub>2</sub> charge	t	56,37	56,37	93,96	93,96	104,40	104,40	
Water tank volume	l	300	300	500	500	500	500	

Performances are referred to the following conditions:

(1) Heating: Ambient temperature 7°C DB, 6°C WB, water temperature 30/35°C.

(2) Average conditions, variable - Reg EU 811/2013

(3) Cooling: ambient air temperature 35°C, evaporator water temperature in/out 12/7 °C.

(4) Sound power level in accordance with ISO 3744.

(5) Sound pressure level at 10 mt from the unit in free field conditions in accordance with ISO 3744.

Reversible heating/cooling version (RV)

HA/XL/RV - P2S/P2U		252	302	432	492	602	752	852
Heating capacity (EN14511) <sup>(1)</sup>	kW	24,0	29,6	41,1	48,9	57,4	65,5	80,1
Total input power (EN14511) <sup>(1)</sup>	kW	5,5	7,0	9,5	12,1	12,9	15,2	18,4
COP (EN14511) <sup>(1)</sup>	W/W	4,40	4,24	4,35	4,04	4,46	4,31	4,35
Energy Class in low temperature <sup>(2)</sup>		A++	A++	A++	A++	A++	A++	A++
SCOP low temperature <sup>(2)</sup>	kWh/kWh	3,83	3,84	3,84	3,83	4,03	4,01	3,83
η <sub>s,h</sub> low temperature <sup>(2)</sup>	%	150	151	151	150	158	158	150
Energy Class in medium temperature <sup>(2)</sup>		A+	A+	A+	A+	A++	A+	A+
SCOP medium temperature <sup>(2)</sup>	kWh/kWh	3,05	3,13	3,11	3,14	3,27	3,20	3,13
η <sub>s,h</sub> medium temperature <sup>(2)</sup>	%	119	122	121	122	128	125	122
Cooling capacity (EN14511) <sup>(3)</sup>	kW	22,0	28,3	36,8	45,5	52,1	62,0	71,2
Total input power (EN14511) <sup>(3)</sup>	kW	7,1	9,1	13,2	16,1	18,9	21,9	23,7
EER (EN14511) <sup>(3)</sup>	W/W	3,10	3,13	2,78	2,82	2,75	2,83	3,00
Sound power <sup>(4)</sup>	dB (A)	72	72	73	74	74	74	74
Sound pressure <sup>(5)</sup>	dB (A)	40	40	41	42	42	42	42
HE/XL/RV - P2S/P2U		252	302	432	492	602	752	852
Heating capacity (EN14511) <sup>(1)</sup>	kW	24,0	30,0	41,2	49,2	57,4	65,6	79,9
Total input power (EN14511) <sup>(1)</sup>	kW	5,2	6,8	9,2	11,8	12,6	15,1	17,8
COP (EN14511) <sup>(1)</sup>	W/W	4,64	4,39	4,49	4,16	4,57	4,35	4,49
Energy Class in low temperature <sup>(2)</sup>		A++	A++	A++	A++	A++	A++	A++
SCOP low temperature <sup>(2)</sup>	kWh/kWh	4,10	3,87	4,00	3,84	4,21	4,16	4,04
η <sub>s,h</sub> low temperature <sup>(2)</sup>	%	161	152	157	151	165	163	159
Energy Class in medium temperature <sup>(2)</sup>		A++	A+	A++	A++	A++	A++	A++
SCOP medium temperature <sup>(2)</sup>	kWh/kWh	3,24	3,14	3,24	3,16	3,38	3,29	3,26
η <sub>s,h</sub> medium temperature <sup>(2)</sup>	%	127	123	127	123	132	129	127
Cooling capacity (EN14511) <sup>(3)</sup>	kW	21,0	28,9	37,2	45,7	52,0	62,1	70,6
Total input power (EN14511) <sup>(3)</sup>	kW	7,0	9,1	12,7	16,0	18,8	21,8	24,2
EER (EN14511) <sup>(3)</sup>	W/W	2,98	3,17	2,93	2,85	2,78	2,85	2,92
Sound power <sup>(4)</sup>	dB (A)	71	72	73	74	73	73	74
Sound pressure <sup>(5)</sup>	dB (A)	39	40	41	42	41	41	42
Power supply	V/Ph/Hz	400/3+N/50	400/3+N/50	400/3/50	400/3/50	400/3/50	400/3/50	400/3/50
Compressors / Circuits	n° / n°	2 / 1	2 / 1	2 / 1	2 / 1	2 / 1	2 / 1	2 / 1
Fans	n°	2	2	2	2	2	2	2
Refrigerant		R410A	R410A	R410A	R410A	R410A	R410A	R410A
Refrigerant charge	kg	10,0	10,0	14,5	12,0	18,0	23,0	23,0
Global warming potential (GWP)		2088	2088	2088	2088	2088	2088	2088
Equivalent CO <sub>2</sub> charge	t	20,88	20,88	30,27	25,05	37,58	48,02	48,02
Water tank volume	l	100	100	100	100	300	300	300
HA/XL/RV - P2S/P2U		1002	1202	1454	1654	1854	2154	
Heating capacity (EN14511) <sup>(1)</sup>	kW	87,3	100,7	147,8	166,9	187,4	218,2	
Total input power (EN14511) <sup>(1)</sup>	kW	20,0	23,8	33,5	38,7	43,1	51,3	
COP (EN14511) <sup>(1)</sup>	W/W	4,37	4,23	4,41	4,31	4,35	4,25	
Energy Class in low temperature <sup>(2)</sup>		A++	A++	A++	A++	A++	A++	
SCOP low temperature <sup>(2)</sup>	kWh/kWh	3,91	3,84	3,93	3,90	3,88	3,88	
η <sub>s,h</sub> low temperature <sup>(2)</sup>	%	153	151	154	153	152	152	
Energy Class in medium temperature <sup>(2)</sup>		A++	A+	A+	A+	A+	A+	
SCOP medium temperature <sup>(2)</sup>	kWh/kWh	3,21	3,18	3,16	3,17	3,10	3,13	
η <sub>s,h</sub> medium temperature <sup>(2)</sup>	%	126	124	123	124	121	122	
Cooling capacity (EN14511) <sup>(3)</sup>	kW	77,1	88,7	126,6	143,4	158,7	184,3	
Total input power (EN14511) <sup>(3)</sup>	kW	26,2	32,6	40,9	48,1	49,7	61,3	
EER (EN14511) <sup>(3)</sup>	W/W	2,95	2,72	3,10	2,98	3,19	3,01	
Sound power <sup>(4)</sup>	dB (A)	75	75	79	79	80	80	
Sound pressure <sup>(5)</sup>	dB (A)	43	43	47	47	48	48	
HE/XL/RV - P2S/P2U		1002	1202	1454	1654	1854	2154	
Heating capacity (EN14511) <sup>(1)</sup>	kW	87,2	100,7	147,6	166,6	187,6	218,2	
Total input power (EN14511) <sup>(1)</sup>	kW	19,4	23,5	32,3	37,6	41,2	49,5	
COP (EN14511) <sup>(1)</sup>	W/W	4,49	4,29	4,57	4,43	4,55	4,41	
Energy Class in low temperature <sup>(2)</sup>		A++	A++	A++	A++	A++	A++	
SCOP low temperature <sup>(2)</sup>	kWh/kWh	4,06	3,93	4,10	4,00	3,94	3,92	
η <sub>s,h</sub> low temperature <sup>(2)</sup>	%	160	154	161	157	154	154	
Energy Class in medium temperature <sup>(2)</sup>		A++	A++	A++	A++	A++	A++	
SCOP medium temperature <sup>(2)</sup>	kWh/kWh	3,33	3,25	3,28	3,29	3,28	3,28	
η <sub>s,h</sub> medium temperature <sup>(2)</sup>	%	130	127	128	129	128	128	
Cooling capacity (EN14511) <sup>(3)</sup>	kW	76,9	88,1	126,5	142,7	158,7	184,3	
Total input power (EN14511) <sup>(3)</sup>	kW	26,3	32,9	40,3	48,4	49,7	60,3	
EER (EN14511) <sup>(3)</sup>	W/W	2,92	2,68	3,14	2,95	3,19	3,05	
Sound power <sup>(4)</sup>	dB (A)	75	75	79	79	80	80	
Sound pressure <sup>(5)</sup>	dB (A)	43	43	47	47	48	48	
Power supply	V/Ph/Hz	400/3/50	400/3/50	400/3/50	400/3/50	400/3/50	400/3/50	
Compressors / Circuits	n° / n°	2 / 1	2 / 1	4/2	4/2	4/2	4/2	
Fans	n°	2	2	4	4	6	6	
Refrigerant		R410A	R410A	R410A	R410A	R410A	R410A	
Refrigerant charge	kg	27,0	27,0	50,0	50,0	55,0	55,0	
Global warming potential (GWP)		2088	2088	2088	2088	2088	2088	
Equivalent CO <sub>2</sub> charge	t	56,37	56,37	104,40	104,40	114,84	114,84	
Water tank volume	l	300	300	500	500	500	500	

Performances are referred to the following conditions:

(1) Heating: Ambient temperature 7°C DB, 6°C WB, water temperature 30/35°C.

(2) Average conditions, variable - Reg EU 811/2013

(3) Cooling: ambient air temperature 35°C, evaporator water temperature in/out 12/7 °C.

(4) Sound power level in accordance with ISO 3744.

(5) Sound pressure level at 10 mt from the unit in free field conditions in accordance with ISO 3744.

Reversible heating/cooling version (RV)

L71

HE/NN/RV - P2S/P2U		252	312	452	502	602	752	852
Heating capacity (EN14511) <sup>(1)</sup>	kW	23,4	30,5	41,1	54,2	60,7	70,4	79,5
Total input power (EN14511) <sup>(1)</sup>	kW	5,0	6,4	8,8	11,7	12,4	14,7	17,41
COP (EN14511) <sup>(1)</sup>	W/W	4,69	4,75	4,69	4,64	4,89	4,78	4,56
Energy Class in low temperature <sup>(2)</sup>		A++	A++	A++	A++	A++	A++	A++
SCOP low temperature <sup>(2)</sup>	kWh/kWh	4,30	4,35	4,23	4,10	4,37	4,40	4,22
η <sub>s,h</sub> low temperature <sup>(2)</sup>	%	169	171	166	161	172	173	166
Energy Class in medium temperature <sup>(2)</sup>		A++	A++	A++	A++	A++	A++	A++
SCOP medium temperature <sup>(2)</sup>	kWh/kWh	3,34	3,48	3,42	3,34	3,47	3,45	3,38
η <sub>s,h</sub> medium temperature <sup>(2)</sup>	%	131	136	134	131	136	135	132
Cooling capacity (EN14511) <sup>(3)</sup>	kW	22,1	28,5	37,0	46,4	53,3	61,6	72,9
Total input power (EN14511) <sup>(3)</sup>	kW	6,9	9,1	12,6	14,9	16,8	20,9	25,1
EER (EN14511) <sup>(3)</sup>	W/W	3,20	3,15	2,93	3,11	3,18	2,95	2,90
Sound power <sup>(4)</sup>	dB (A)	68	69	71	71	71	72	72
Sound pressure <sup>(5)</sup>	dB (A)	36	37	39	39	39	40	40
Power supply	V/Ph/Hz	400/3+N/50	400/3/50	400/3/50	400/3/50	400/3/50	400/3/50	400/3/50
Compressors / Circuits	n° / n°	2 / 1	2 / 1	2 / 1	2 / 1	2 / 1	2 / 1	2 / 1
Fans	n°	2	2	2	2	2	2	2
Refrigerant		R410A	R410A	R410A	R410A	R410A	R410A	R410A
Refrigerant charge	kg	10,0	10,0	18,0	23,0	18,0	23,0	23,0
Global warming potential (GWP)		2088,0	2088	2088	2088	2088	2088	2088
Equivalent CO <sub>2</sub> charge	t	20,88	20,88	37,58	48,02	37,58	48,02	48,02

HE/NN/RV - P2S/P2U		1002	1202	1454	1654	1854	2154
Heating capacity (EN14511) <sup>(1)</sup>	kW	90,3	104,9	146,7	165,1	184,7	214,0
Total input power (EN14511) <sup>(1)</sup>	kW	18,6	22,1	31,5	36,6	40,0	48,0
COP (EN14511) <sup>(1)</sup>	W/W	4,87	4,75	4,66	4,51	4,62	4,46
Energy Class in low temperature <sup>(2)</sup>		A++	A++	A++	A++	A++	A++
SCOP low temperature <sup>(2)</sup>	kWh/kWh	4,42	4,31	4,31	4,15	4,23	4,12
η <sub>s,h</sub> low temperature <sup>(2)</sup>	%	174	169	169	163	166	162
Energy Class in medium temperature <sup>(2)</sup>		A++	A++	A++	A++	A++	A++
SCOP medium temperature <sup>(2)</sup>	kWh/kWh	3,52	3,50	3,41	3,40	3,47	3,42
η <sub>s,h</sub> medium temperature <sup>(2)</sup>	%	138	137	134	133	136	134
Cooling capacity (EN14511) <sup>(3)</sup>	kW	79,0	91,9	124,7	139,5	156,5	179,9
Total input power (EN14511) <sup>(3)</sup>	kW	24,7	29,8	41,5	50,9	50,8	63,3
EER (EN14511) <sup>(3)</sup>	W/W	3,20	3,08	3,01	2,74	3,08	2,84
Sound power <sup>(4)</sup>	dB (A)	72	72	74	74	75	75
Sound pressure <sup>(5)</sup>	dB (A)	40	40	42	42	43	43
Power supply	V/Ph/Hz	400/3/50	400/3/50	400/3/50	400/3/50	400/3/50	400/3/50
Compressors / Circuits	n° / n°	2 / 1	2 / 1	4/2	4/2	4/2	4/2
Fans	n°	3	3	4	4	6	6
Refrigerant		R410A	R410A	R410A	R410A	R410A	R410A
Refrigerant charge	kg	36,0	36,0	50,0	50,0	55,0	55,0
Global warming potential (GWP)		2088	2088	2088	2088	2088	2088
Equivalent CO <sub>2</sub> charge	t	75,16	75,16	104,40	104,40	114,84	114,84

Performances are referred to the following conditions:

(1) Heating: Ambient temperature 7°C DB, 6°C WB, water temperature 30/35°C.

(2) Average conditions, variable - Reg EU 811/2013

(3) Cooling: ambient air temperature 35°C, evaporator water temperature in/out 12/7 °C.

(4) Sound power level in accordance with ISO 3744.

(5) Sound pressure level at 10 mt from the unit in free field conditions in accordance with ISO 3744.

## What is the E.V.I. Technology (Enhanced Vapour Injection)?

Heat pumps utilise scroll compressors that are equipped with E.V.I. technology, a versatile method of improving system capacity and efficiency. EVI stands for "Economised Vapour Injection."

The technology involves injecting refrigerant vapour into the middle of the compression process, a procedure that significantly boosts capacity and efficiency. Each scroll compressor used in these units is similar to a two-stage compressor with built-in inter-stage cooling. The process begins when a portion of the condenser liquid is extracted and expanded through an expansion valve.

The low temperature liquid/gas mixture produced is injected into a heat exchanger that operates as a sub cooler. Any liquid is evaporated and the vapour produced is superheated.

The superheated vapour is then injected into an intermediate port in the scroll compressor. This cold vapour reduces the temperature of the compressed gas thus enabling the compressor to raise the pressure to levels (and temperatures) beyond that possible with a single stage scroll. The additional sub cooling of the main volume of liquid refrigerant increases the evaporator capacity. This compressor technology generates a larger pressure ratio between condensing and evaporating pressures, with significant performance improvement. Using this technology enables Hidros units to produce hot water up to 65°C and the ability to operate down to -20°C ambient temperature.

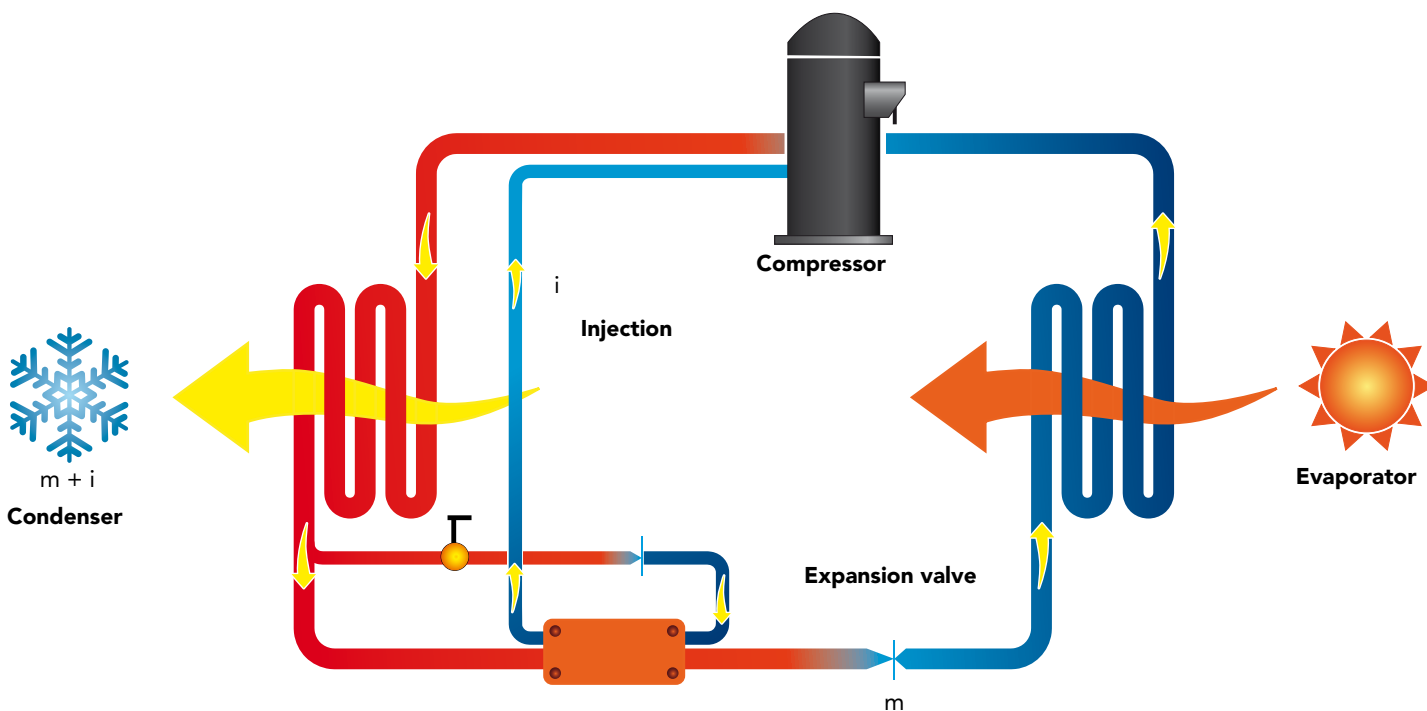
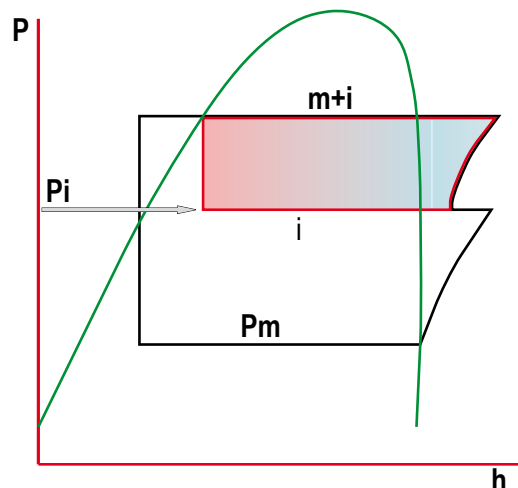

## COMPONENTS

### FRAME

All units are made from hot-galvanised sheet steel, painted with polyurethane powder enamel and stoved at 180°C to provide maximum protection against corrosion. The frame is self-supporting with removable panels. All screws and rivets used are made from stainless steel. The standard colour of the units is RAL9018.

### REFRIGERANT CIRCUIT

The refrigerant utilised is R410A. The refrigerant circuit is assembled using internationally recognised brand name components with all brazing and welding being performed in accordance with ISO 97/23. The refrigerant circuit includes: sight glass, filter drier, two thermal expansion valves (one for cooling mode, one for heating mode) with external equalizer, 4 way reversing valve, check valves, liquid receiver, Schrader valves for maintenance and control, pressure safety device (for compliance with PED regulations). The circuit also includes an AISI316 stainless steel heat exchanger that is used as an economizer plus an additional expansion valve for refrigerant vapour injection.

### COMPRESSORS

Units use scroll compressors that are equipped with E.V.I. technology, a versatile method of improving system capacity and efficiency. EVI stands for "Enhanced Vapour Injection." The technology involves injecting refrigerant vapour into the middle of the compression process, a procedure that significantly boosts capacity and efficiency. Each scroll compressor used in these units is similar to a two-stage compressor with built-in inter-stage cooling. The process begins when a portion of the condenser liquid is extracted and expanded through an expansion valve. The low temperature liquid/gas mixture produced is injected into a heat exchanger that operates as a sub cooler. Any liquid is evaporated and the vapour produced is superheated.

The superheated vapour is then injected into an intermediate port in the scroll compressor. This cold vapour reduces the temperature of the compressed gas thus enabling the compressor to raise the pressure to levels (and temperatures) beyond that possible with a single stage scroll. The additional sub cooling of the main volume of liquid refrigerant increases the evaporator capacity. This compressor technology generates a larger pressure ratio between condensing and evaporating pressures, with significant performance improvement. In all units the compressors are connected in tandem. The compressors are all supplied with a crankcase heater and thermal overload protection by a klixon embedded in the motor winding. They are mounted in a separate enclosure in order to be separated from the air stream thus enabling them to be maintained even if the unit is operating. Access to this enclosure is by the front panel of the unit. The crankcase heater is always powered when the compressor is in stand-by.

### SOURCE HEAT EXCHANGER

The source heat exchanger is made from copper pipes and aluminium fins. Dimensioning of the copper pipes and the aluminium fins is optimized in order to obtain excellent performance. The tubes are mechanically expanded into the fins in order to maximise heat transfer. Furthermore, the design guarantees a low air side pressure drop thus enabling the use of low rotation speed (and hence low noise) fans. All heat exchangers are supplied standard with fins hydrophilic coating.

### USER HEAT EXCHANGERS

The user heat exchanger is a braze welded, plate type heat exchanger, manufactured from AISI 316 stainless steel. The use of this type of exchanger results in a massive reduction of the refrigerant charge of the unit compared to a traditional shell-in-tube type. A further advantage is a reduction in the overall dimensions of the unit. The exchangers are factory insulated with flexible close cell material and can be fitted with an antifreeze

heater (accessory). Each exchanger is fitted with a temperature sensor on the discharge water side for antifreeze protection.

### FANS

The fans are direct drive axial type with aluminium aerofoil blades, are statically and dynamically balanced and are supplied complete with a safety fan guard complying with the requirements of EN 60335. They are fixed to the unit frame via rubber antivibration mountings. In the LS versions the fans are 6 poles type (approx 900 rpm), in the XL versions the fans are 8 poles type (approx 600 rpm), in the NN versions the fans are 12 poles type (approx 450 rpm). The motors are fitted with integrated thermal overload protection and have a moisture protection rating of IP 54.

### MICROPROCESSORS

All units are supplied as standard complete with control panel. The microprocessor controls the following functions: control of the water temperature, antifreeze protection, compressor timing, compressor automatic starting sequence (For multiple compressors), alarm reset.

The control panel is supplied with display showing all operational icons. The microprocessor is set for automatic defrost (when operating in severe ambient conditions) and for summer/ winter change over (only for RV versions).

The control also manages the anti-legionella program, the integration with other heating sources (electric heaters, boilers, solar panels etc), the operation of a three port modulating valve (for diverting to DHW or heating) and both the heating circuit pump and the domestic hot water circuit pump. If required (available as an option), the microprocessor can be configured in order for it to connect to a site BMS system thus enabling remote control and management.

### ELECTRIC ENCLOSURE

The enclosure is manufactured in order to comply with the requirements of the electromagnetic compatibility standards CEE EN60204. Access to the enclosure is achieved by removing the front panel of the unit. The following components are supplied as standard on all units: main switch, a sequence relay that disables the power supply in the event that the phase sequence is incorrect (scroll compressors can be damaged if they rotate in the wrong direction), thermal overloads (protection of pumps and fans), overload switches, control circuit automatic breakers, compressor contactors, automatic switches and pump contactors. The terminal board has volt free contacts for remote ON-OFF, Summer/ winter change over (heat pumps only) and general alarm.

### CONTROL AND PROTECTION DEVICES

All units are supplied with the following controls and protections: user water return temperature sensor, antifreeze protection temperature sensor installed on users water output, domestic hot water supply and return temperature sensors (only versions P2S), high pressure manual reset, low pressure automatic reset, compressor thermal protection, air fan, thermal protection, pressure transducer (used to optimize the defrost cycle and to adjust the fan speed depending on ambient conditions), flow switch. All units are also fitted with a temperature probe sensor with "Energy Saving" function, supplied in a separate plastic box, which can be used to stop the pump use during periods of stand-by, when the water temperature reaches the set point. Doing this the power consumption of the unit is strongly reduced. The probe sensor must be positioned in the hydraulic compensator present at the screening technique. The domestic hot water circuit (only versions P2S) is already equipped with this probe, but it must be installed in the user circuit.

## VERSIONS

### HH Version

HH heating only versions are available in the P2U and P2S configuration only.

### RV Version

This version uses 2 hydraulic connections and is able to produce hot water in winter and cold water in summer. The unit is combined with a 2-pipe system.

### SA Version

Standard efficiency version, according to current standard. Unit equipped with AC fans.

### SE Version

Standard efficiency version, according to current standard. Unit equipped with EC fans.

### HA Version

High efficiency version, according to current standard. Unit equipped with AC fans.

### HE Version

High efficiency version, according to current standard. Unit equipped with EC fans.

### LS Version

This version includes the complete acoustic insulation of the unit with compressor jackets and insulating material made with high density media and the interposition of heavy bitumen layer.

### P2U Version

This is a two pipe version that can produce hot water for heating (HH heating only) and hot or cold water in the RV version. The RV is used with two pipe water based change-over systems. It is not able to produce domestic hot water.

### P2S Version

This is a two pipe version that can, in addition to producing hot water for heating (HH version) and hot and cold water in the RV version can also generate domestic hot water. The controller has dual heating set points (heating and DHW) and can also control a three port diverting valve that directs the DHW to the cylinder. DHW production has priority irrespective of the mode of operation of the unit. The unit is normally used with two pipe water based change-over systems.

### Super low noise and ultra low noise versions XL and NN

All units in XL and NN versions are supplied, as standard, with the latest 'Floating Frame' technology that completely isolates the compressors from the main casing, thereby eliminating vibration and noise from this source. The 'Floating Frame' is a special vibration and acoustic damping system that consists of a base plate and acoustic enclosure that houses the compressors. The base plate is separated from the supporting frame of the unit by soft steel springs that have a high damping power. Within the enclosure, the compressors are mounted on rubber shock absorbers on the floating base plate. The enclosure is manufactured from galvanized steel sandwich panels that have a micro-perforated inner skin and a core of 30 mm thick, high density (25 kg/m<sup>3</sup>). The entire arrangement provides a double damping system and acoustic attenuation. The compressor refrigerant pipes are connected to the refrigerant circuit through "anaconda" flexible connections. Flexible connections are also used on the water pipework within the unit. The combination of these systems results in an overall noise reduction in the region of 6-8 dB(A).

## OPERATION LIMITS

(SA/SE versions)

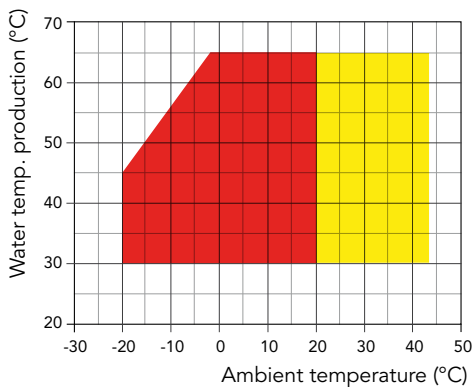

(HA/HE versions)

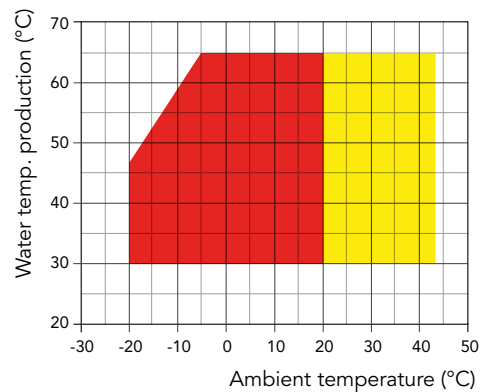

(RV versions Only)

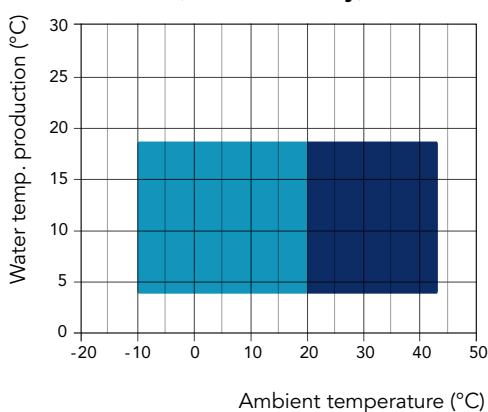

- Heating mode
- Heating mode with head pressure control (DCCF)
- Cooling with head pressure control (DCCF)
- Cooling mode

# ACCESSORIES

LZT

LZT		242 / 252	292 / 302	312	432	452	492	502	592	602
Flow switch		●	●	●	●	●	●	●	●	●
"Floating frame" Technology - LS Version		-	-	-	-	-	-	-	-	-
"Floating frame" Technology - XL - NN Version		●	●	●	●	●	●	●	●	●
E.C. fans - SA/LS versions	VECE	-	-	-	-	-	-	-	-	-
E.C. fans - SE/LS versions	VECE	●	●	●	●	●	●	●	●	●
E.C. fans - HA/LS - HA/XL versions	VECE	-	-	-	-	-	-	-	-	-
E.C. fans - HE/LS - HE/XL - HE/NN versions	VECE	●	●	●	●	●	●	●	●	●
Condensate discharge drip tray with antifreeze heater	BRCA	○	○	○	○	○	○	○	○	○
Cond.pressure control - transducer & EC Fans (only for SE and HE)	VECE	●	●	●	●	●	●	●	●	●
Fans regulation by phase cut (only SA - HA)	DCCF	X	X	X	X	X	X	X	X	X
Antifreeze kit for 2 pipe units	RAEV2	○	○	○	○	○	○	○	○	○
Electronic soft starter	DSSE	○	○	○	○	○	○	○	○	○
Serial interface card RS485	INSE	●	●	●	●	●	●	●	●	●
Rubber anti-vibration mountings	KAVG	○	○	○	○	○	○	○	○	○
Remote control panel	PCRL	○	○	○	○	○	○	○	○	○
Electronic expansion valve	VTEE	○	○	○	○	○	○	○	○	○
Cascade control system via RS485	SGRS	○	○	○	○	○	○	○	○	○
Hydraulic kit with one pump with tank *	A1ZZU	○	○	○	○	○	○	○	○	○
Hydraulic kit with two pumps with tank *	A2ZZU	○	○	○	○	○	○	○	○	○
Hydraulic kit with one pump without tank *	A1NTU	○	○	○	○	○	○	○	○	○
Hydraulic kit with two pumps without tank *	A2NTU	○	○	○	○	○	○	○	○	○

\* Not available for NN versions

X Necessary for P2S version  
Optional for P2U version

● Standard ○ Optional - Not available

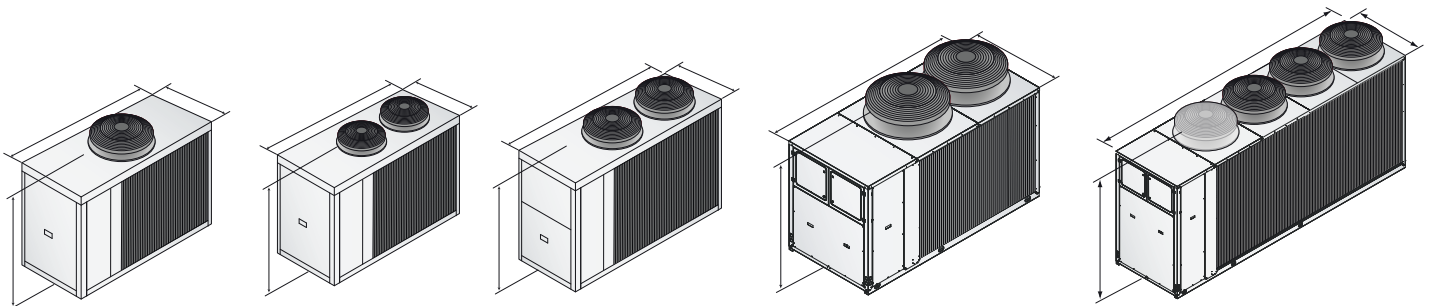

		242/252	292/302	312	432	452	492	502	592	602
A (mm)	SA-SE/LS	1500	1500	--	1690	--	1690	--	1690	--
B (mm)	SA-SE/LS	1915	1915	--	2400	--	2400	--	2400	--
C (mm)	SA-SE/LS	875	875	--	1150	--	1150	--	1150	--
kg	SA-SE/LS	1000	1000	--	1500	--	1500	--	1500	--
A (mm)	HA-HE/LS	1500	1500	--	1690	--	1690	--	--	1820
B (mm)	HA-HE/LS	1915	1915	--	2400	--	2400	--	--	2905
C (mm)	HA-HE/LS	875	875	--	1150	--	1150	--	--	1150
kg	HA-HE/LS	1000	1000	--	1500	--	1500	--	--	1060
A (mm)	HA-HE/XL	1500	1500	--	1690	--	1690	--	--	1820
B (mm)	HA-HE/XL	1915	1915	--	2400	--	2400	--	--	2905
C (mm)	HA-HE/XL	875	875	--	1150	--	1150	--	--	1150
kg	HA-HE/XL	1000	1000	--	1500	--	1500	--	--	1080
A (mm)	HE/NN	1500	--	1690	--	1820	--	1880	--	1880
B (mm)	HE/NN	1915	--	2400	--	2905	--	2905	--	2905
C (mm)	HE/NN	875	--	1150	--	1150	--	1150	--	1150
kg	HE/NN	1000	--	1500	--	1080	--	1100	--	1110

LZT		752	852	1002	1202	1454	1654	1854	2154
Flow switch		●	●	●	●	●	●	●	●
"Floating frame" Technology - LS Version		-	-	-	-	-	-	-	-
"Floating frame" Technology - XL - NN Version		●	●	●	●	●	●	●	●
E.C. fans - SA/LS versions	VECE	-	-	-	-	-	-	-	-
E.C. fans - SE/LS versions	VECE	●	●	●	●	●	●	●	●
E.C. fans - HA/LS - HA/XL versions	VECE	-	-	-	-	-	-	-	-
E.C. fans - HE/LS - HE/XL - HE/NN versions	VECE	●	●	●	●	●	●	●	●
Condensate discharge drip tray with antifreeze heater	BRCA	○	○	○	○	○	○	○	○
Cond.pressure control - transducer & EC Fans (only for SE and HE)	VECE	●	●	●	●	●	●	●	●
Fans regulation by phase cut (only SA - HA)	DCCF	X	X	X	X	X	X	X	X
Antifreeze kit for 2 pipe units	RAEV2	○	○	○	○	○	○	○	○
Electronic soft starter	DSSE	○	○	○	○	○	○	○	○
Serial interface card RS485	INSE	●	●	●	●	●	●	●	●
Rubber anti-vibration mountings	KAVG	○	○	○	○	○	○	○	○
Remote control panel	PCRL	○	○	○	○	○	○	○	○
Electronic expansion valve	VTEE	○	○	○	○	○	○	○	○
Cascade control system via RS485	SGRS	○	○	○	○	○	○	○	○
Hydraulic kit with one pump with tank *	A1ZZU	○	○	○	○	○	○	○	○
Hydraulic kit with two pumps with tank *	A2ZZU	○	○	○	○	○	○	○	○
Hydraulic kit with one pump without tank *	A1NTU	○	○	○	○	○	○	○	○
Hydraulic kit with two pumps without tank *	A2NTU	○	○	○	○	○	○	○	○

\* Not available for NN versions

X Necessary for P2S version  
Optional for P2U version

● Standard ○ Optional – Not available

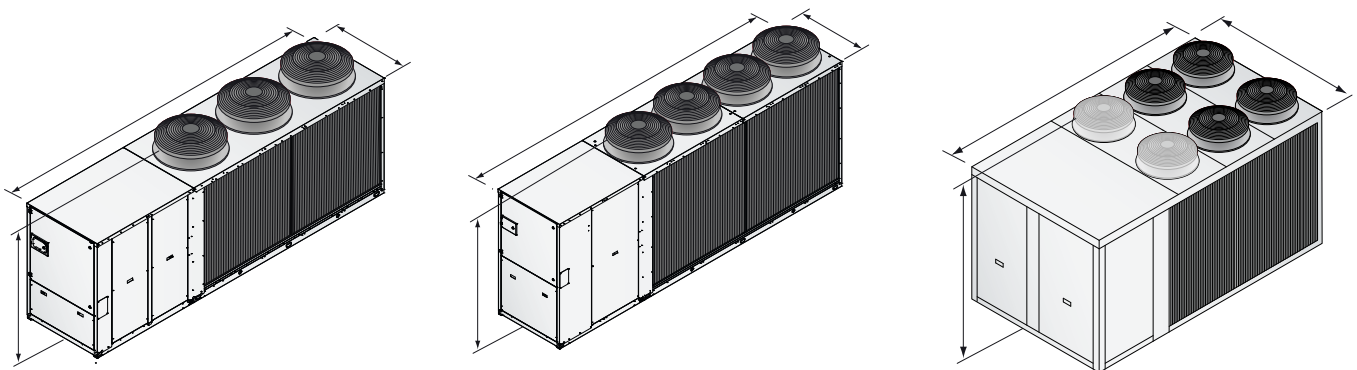

		752	852	1002	1202	1454	1654	1854	2154
A (mm)	SA-SE/LS	1880	1880	1890	1890	2310	2310	2310	2310
B (mm)	SA-SE/LS	2905	2905	3905	3905	5300	5300	5300	5300
C (mm)	SA-SE/LS	1150	1150	1150	1150	1150	1150	1150	1150
kg	SA-SE/LS	2000	2000	2000	2000	2500	2540	2580	2620
A (mm)	HA-HE/LS	1880	1880	1880	1880	1895	1895	1895	1895
B (mm)	HA-HE/LS	2905	2905	2905	2905	4695	4695	4695	4695
C (mm)	HA-HE/LS	1150	1150	1150	1150	1150	1150	1150	1150
kg	HA-HE/LS	2000	2000	2000	2000	2580	2640	2720	2760
A (mm)	HA-HE/XL	1880	1880	1880	1880	2350	2350	2350	2350
B (mm)	HA-HE/XL	2905	2905	2905	2905	4205	4205	4205	4205
C (mm)	HA-HE/XL	1150	1145	1150	1150	2210	2210	2210	2210
kg	HA-HE/XL	2000	2000	2000	2000	2500	2540	2580	2620
A (mm)	HE/NN	1880	1880	1890	1890	2350	2350	2350	2350
B (mm)	HE/NN	2905	2905	3905	3905	4205	4205	4205	4205
C (mm)	HE/NN	1150	1145	1150	1150	2210	2210	2210	2210
kg	HE/NN	2000	2000	2000	2000	2750	2800	2840	2890

# LZTi

## HIGH EFFICIENCY AIR TO WATER HEAT PUMPS

EQUIPPED WITH DC INVERTER COMPRESSOR WITH VAPOR INJECTION (EVI)  
AND AXIAL FANS

Heating power from 7 kW to 19 kW

R410A

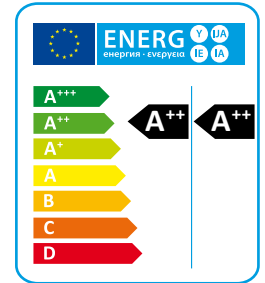

The LZTi series of high efficiency heat pumps has been specifically designed for use with radiant floor heating systems or those applications where it is necessary to have maximum efficiency when heating.

They have been optimized on heating mode, are able to produce water up to 65°C and can operate down to -20°C ambient temperature.

LZTi units are available in 2 or 4 pipe (SW6) versions. Both versions can produce domestic hot water, in the standard LZTi through the activation of an external 3-way-valve and in the SW6 version by means of a separate heat exchanger and hydraulic circuit for the domestic hot water.

All models are supplied as standard with a reversing valve for defrost and cold water production in summer.

## VERSIONS

**STD** 2 pipes reversible standard.

**SW6** 4 pipes unit capable of producing hot and cold water at the same time on two independent hydraulic circuits.

LZTi - LZTi/SW6		09	11	16	21
Heating capacity (EN14511) <sup>(1)</sup>	kW	7,7	9,6	15,0	19,0
Total input power (EN14511) <sup>(1)</sup>	kW	1,8	2,3	3,4	4,5
COP (EN14511) <sup>(1)</sup>	W/W	4,28	4,17	4,41	4,22
Energy Class in low temperature <sup>(2)</sup>		A++	A++	A++	A++
SCOP low temperature <sup>(2)</sup>	kWh/ kWh	4,05	4,08	4,27	4,16
ns,h low temperature <sup>(2)</sup>	%	153,8	155,8	157,3	157,8
Energy Class in medium temperature <sup>(2)</sup>		A+	A+	A++	A++
SCOP medium temperature <sup>(2)</sup>	kWh/ kWh	3,39	3,46	3,61	3,54
ηs,h medium temperature <sup>(2)</sup>	%	132,0	135,0	142,0	139,0
Cooling capacity (EN14511) <sup>(3)</sup>	kW	7,1	8,5	13,5	16,0
Total input power (EN14511) <sup>(3)</sup>	kW	2,3	2,8	4,2	5,1
EER (EN14511) <sup>(3)</sup>	W/W	3,10	3,04	3,21	3,14
Power supply	V/Ph/Hz	230/1/50	230/1/50	400/3+N/50	400/3+N/50
Max input current standard unit	A	21,9	21,9	15,8	15,8
Peak current standard unit	A	31,0	31,0	22,8	22,8
Fans	n°	1	1	2	2
Compressors	n°	1 E.VI. DC inverter	1 E.VI. DC inverter	1 E.VI. DC inverter	1 E.VI. DC inverter
Refrigerant		R410A	R410A	R410A	R410A
Global warming potential (GWP)		2088	2088	2088	2088
Refrigerant charge	kg	3,3	3,3	4,3	4,3
Equivalent CO <sub>2</sub> charge	t	6,9	6,9	9,0	9,0
Sound power <sup>(4)</sup>	dB (A)	68	68	74	74
Sound pressure <sup>(5)</sup>	dB (A)	40	40	46	46

Performances are referred to the following conditions:

(1) Heating: Ambient temperature 7°C DB, 6°C WB, water temperature 30/35°C.

(2) Average conditions, low temperature, variable - Reg EU 811/2013.

(3) Cooling: ambient temperature 35°C, water temperature 12/7°C.

(4) Sound power level in accordance with ISO 3744.

(5) Sound pressure level at 10 mt from the unit in free field conditions in accordance with ISO 3744.

## COMPONENTS

### FRAME

All units are made from hot-galvanised sheet steel, painted with polyurethane powder enamel and stoved at 180°C to provide maximum protection against corrosion. The frame is self-supporting with removable panels. All screws and rivets used are made from stainless steel.

The standard colour of the units is RAL9018.

### REFRIGERANT CIRCUIT

The refrigerant circuit is made by using components from leading international companies in accordance with ISO 97/23 for the of braze welding processes.

The refrigerant used is R410A.

The refrigerant circuit includes: sight glass, filter drier, electronic expansion valve, 4-way valve, check valves, liquid receiver, Schrader valves for maintenance and control, a safety device (according to PED regulation).

The units are also equipped with plate heat exchanger AISI316 used as economizer circuit and additional thermostatic steam injection.

### COMPRESSORS

The compressors are high-efficiency scroll type, variable-speed modulation capability through DC inverter, supplied with a special design that increases the efficiency of the refrigeration cycle under conditions of very low ambient temperature.

The units are equipped with an economizer and a steam injection system, a versatile method to improve the capacity and efficiency of the system.

The technology of steam injection, consists into injecting the refrigerant vapor in the middle of the compression process, to increase significantly the capabilities and efficiencies too.

The compressors are equipped with an innovative electric motor permanent magnet brushless DC inverter-driven, high-efficiency, are all equipped with electrical resistance and thermal overload protection.

### SOURCE HEAT EXCHANGER

The source heat exchanger is made from 3/8" copper pipes and 0,1mm thick aluminium fins with the tubes being mechanically expanded into the aluminium fins in order to maximise heat transfer. Furthermore, the design guarantees a low air side pressure drop thus enabling the use of low rotation speed (and hence low noise) fans.

### USER HEAT EXCHANGERS

The user heat exchanger is a braze welded, plate type heat exchanger, manufactured from AISI 316 stainless steel. Utilisation of this type of exchanger results in a massive reduction of the refrigerant charge of the unit compared to a traditional shell-in-tube type. A further advantage is a reduction in the overall dimensions of the unit.

The exchangers are factory insulated with flexible close cell material and can be fitted with an antifreeze heater (accessory). Each exchanger is fitted with a temperature sensor on the discharge water side for antifreeze protection.

### HIGH EFFICIENCY AXIAL FANS

High efficiency E.C. axial fans, supplied with Brushless DC electric motors electronically commutated (E.C. motors) able to grants the highest energy efficiency class, according to the latest EU specifications, with the result of substantial energy consumption reduction for ventilation and noise reduction thanks to the new ultra efficient blade profiling. The fans are statically and dynamically balanced and supplied complete with a safety fan guard complying with the requirements of EN 60335. The fans are installed using a special steel profiled beam who minimize all vibrations transmitted to the frame and can modulate their speed till very low values, reducing in this way the electrical consumptions and the noise level during most of their operation. On all units we can control evaporating/condensing pressure by reading the pressure transducer and the continuous modulation of the EC fans rotation speed. The motors have a moisture protection rating of IP 54.

## MICROPROCESSORS

All units are supplied as standard with microprocessor controls. The microprocessor controls the following functions: control of the water temperature, antifreeze protection, compressor timing, compressor automatic starting sequence (For multiple compressors), alarm reset. The control panel is supplied with display showing all operational icons. The microprocessor is set for automatic defrost (when operating in severe ambient conditions) and for summer/ winter change over.

The control also manages the anti-legionella program, the integration with other heating sources (electric heaters, boilers, solar panels etc), the operation of a three port modulating valve (for diverting to DHW or heating) and both the heating circuit pump and the domestic hot water circuit pump. If required (available as an option), the microprocessor can be configured in order for it to connect to a site BMS system thus enabling remote control and management. The Hidros technical department can discuss and evaluate, in conjunction with the customer, solutions using MODBUS protocols.

## ELECTRIC ENCLOSURE

The enclosure is manufactured in order to comply with the requirements of the electromagnetic compatibility standards CEE EN60204. Access to the enclosure is achieved by removing the front panel of the unit. The following components are supplied as standard on all units: main switch, a sequence relay that disables the power supply in the event that the phase sequence is incorrect (scroll compressors can be damaged if they rotate in the wrong direction), thermal overloads (protection of pumps and fans), compressor fuses, control circuit automatic breakers, compressor contactors, fan contactors and pump contactors. The terminal board has volt free contacts for remote ON-OFF, Summer/ winter change over (heat pumps only) and general alarm.

## CONTROL AND PROTECTION DEVICES

All units are supplied with the following controls and protections: user water return temperature sensor, antifreeze protection temperature sensor installed on users water output, domestic hot water supply and return temperature sensors (only versions SW6), high pressure manual reset, low pressure automatic reset, compressor thermal protection, air fan, thermal protection, pressure transducer (used to optimize the defrost cycle and to adjust the fan speed depending on ambient conditions), flow switch. All units are also fitted with a temperature probe sensor with "Energy Saving" function, supplied in a separate plastic box, which can be used to stop the pump use during periods of stand-by, when the water temperature reaches the set point. Doing this the power consumption of the unit is strongly reduced.

## NOISE REDUCTION

All units are supplied, as standard, with the latest 'Floating Frame' technology that completely isolates the compressors from the main casing, thereby eliminating vibration and noise from this source. The 'Floating Frame' is a special vibration and acoustic damping system that consists of a base plate and acoustic enclosure that houses the compressors. The base plate is separated from the supporting frame of the unit by soft steel springs that have a high damping power. Within the enclosure, the compressors are mounted on rubber shock absorbers on the floating base plate. The enclosure is manufactured from galvanized steel sandwich panels that have a micro-perforated inner skin and a core of 30 mm thick, high density (25 kg/m<sup>3</sup>). The entire arrangement provides a double damping system and acoustic attenuation. The compressor refrigerant pipes are connected to the refrigerant circuit through "anaconda" flexible connections. Flexible connections are also used on the water pipework within the unit. The combination of these systems results in an overall noise reduction in the region of 6-8 dB(A).

## VERSIONS

### Unit with independent domestic hot water production (SW6)

This version is fitted with an additional heat exchanger, used as condenser, to produce domestic hot water irrespective of the operation mode of the unit. The activation of the additional heat exchanger is performed automatically by the microprocessor control when the domestic hot water temperature, measured by the sensor, is lower than the required set point. If, during the summer months, the unit is operating on cooling, this version can produce hot and cold water simultaneously. This version is equipped with return and supply domestic hot water sensors and an advanced control panel with specific software for management of the system priorities.

## OPERATION LIMITS

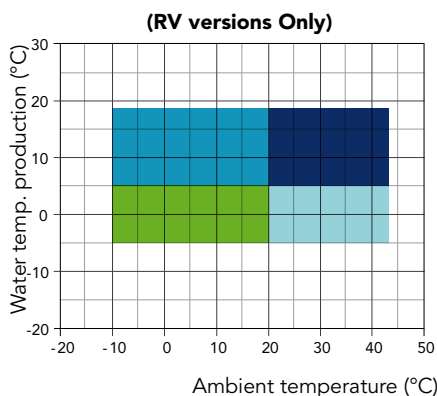
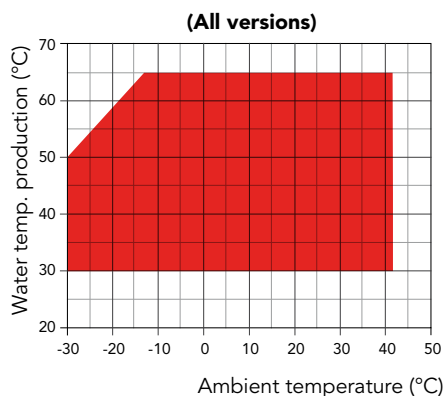

- Heating mode
- Cooling with head pressure control
- Cooling mode
- Cooling with head pressure control and glycol
- Cooling with glycol

## VERSIONS

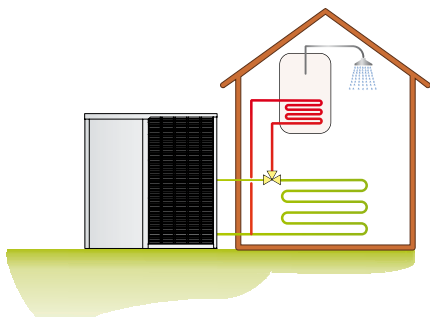

**LZTi 2 pipes version**

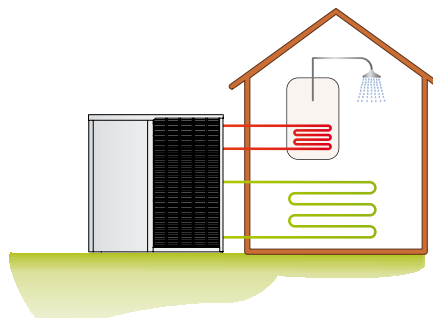

**LZTi/SW6 4 pipes version**

LZTi - LZTi/SW6		09	11	16	21
Main switch		●	●	●	●
Compressor automatic switch		●	●	●	●
Flow switch		●	●	●	●
Fans regulation by phase cut	<b>DCCF</b>	●	●	●	●
Fresh air temperature probe for set-point compensation	<b>SOND</b>	●	●	●	●
Specific software for operation priorities		●	●	●	●
Remote ON/OFF digital input		●	●	●	●
Summer/Winter digital input		●	●	●	●
Floating frame technology		●	●	●	●
Condensate discharge drip tray with antifreeze heater	<b>BRCA</b>	●	●	●	●
Electronic Expansion Valve	<b>VTEE</b>	●	●	●	●
Electronic Soft starter	<b>DSSE</b>	●	●	●	●
Remotable control panel		●	●	●	●
High efficiency fans		●	●	●	●
E1NT Hydraulic kit (pump only)	<b>E1NT</b>	○	○	○	○
Rubber anti-vibration mountings.	<b>KAVG</b>	○	○	○	○
Antifreeze kit	<b>RAES</b>	○	○	○	○
Serial interface card RS485 with MODBUS protocol	<b>INSE</b>	●	●	●	●

● Standard, ○ Optional, – Not available.

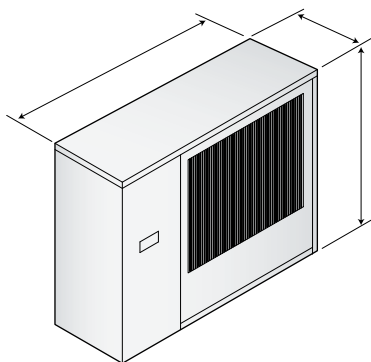

**LZTi 09+11**

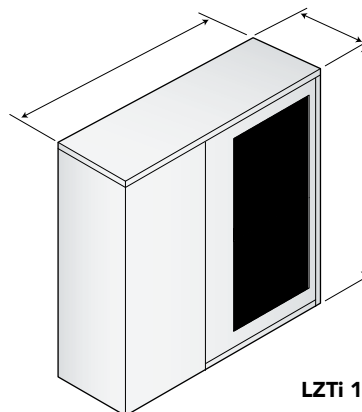

**LZTi 16+21**

Mod.	A (mm)	B (mm)	C (mm)	kg
<b>09</b>	1250	1370	555	180
<b>11</b>	1250	1370	555	180

Mod.	A (mm)	B (mm)	C (mm)	kg
<b>16</b>	1450	1600	555	212
<b>21</b>	1450	1600	555	212

# WZT

## HIGH EFFICIENCY AIR TO WATER SPLIT SYSTEM HEAT PUMPS EQUIPPED WITH E.V.I. COMPRESSORS IN TWO SECTIONS

Heating capacity from 24 kW to 102 kW

R410A

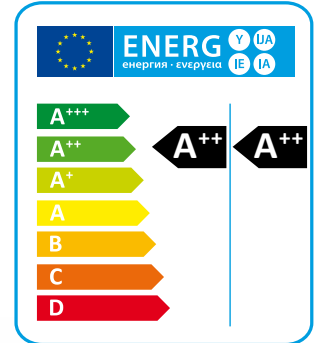

The air source high efficiency heat pumps WZT series, in the NN configuration, are particularly suitable for those applications where it is necessary to have maximum efficiency in heating mode and a noise level extremely low and, for this purpose, are provided in two sections, linked together by refrigerant lines, installing the compressor in the internal section. The units have been designed specifically to have the best possible efficiency, they may operate down to ambient temperatures of -20°C and produce hot water up to 65°C. The units are available in 2-pipe (P2S, P2U), version 2 + 2 pipe (P4S), and in version 4 pipe (P4U).

The units P2U are not able to produce sanitary hot water, the P2S versions are able to produce domestic hot water through the activation of an external 3-way valve (not supplied), while P4S versions and P4U too are able to produce hot water regardless of the mode unit is operating, through the activation of a specific refrigerating circuit. All models are equipped with reverse cycle valve for winter defrost mode, RV versions are also able to produce cold water in summer (not available for HH version).

The noise level is extremely contained thanks to the use

of a special floating system vibration damping that enables a reduction in terms of noise about 6-8 db (A) of compressors side and the fans in the combination with the specific number of turns extremely low (about 450 rpm).

### VERSIONS

- HH** Heating only.
- RV** Reversible heating/cooling.
- HE** High efficiency, EC fans.
- NN** Ultra low noise.
- P2U** 2 pipe systems without domestic hot water production.
- P2S** 2 pipe systems with domestic hot water production by external 3 way valve.
- P4U** 4 pipe systems heating/cooling.
- P4S** 2+2 pipe systems with domestic hot water production.

## TECHNICAL DATA

### Heating only version (HH)

HE/NN/HH		262	312	462	512	612	762	862	1012	1212
Heating capacity (EN14511) <sup>(1) *</sup>	kW	24,1	29,9	44,0	53,7	59,7	69,5	80,5	87,8	101,8
Total input power (EN14511) <sup>(1) *</sup>	kW	5,0	6,4	9,0	11,9	12,5	15,1	17,4	19,0	22,9
COP (EN14511) <sup>(1) *</sup>	W/W	4,86	4,66	4,91	4,50	4,78	4,61	4,63	4,62	4,44
Energy Class in low temperature <sup>(2) *</sup>		A++	A++	A++	A++	A++	A++	A++	A++	A++
SCOP low temperature <sup>(2) *</sup>	kWh/kWh	4,36	4,22	4,17	3,87	4,23	4,19	4,12	4,16	4,06
η <sub>s,h</sub> low temperature <sup>(2) *</sup>	%	171,4	165,6	163,8	151,6	166,1	164,6	161,9	163,3	159,3
Energy Class in medium temperature <sup>(2) *</sup>		A++	A++	A++	A++	A++	A++	A++	A++	A++
SCOP medium temperature <sup>(2) *</sup>	kWh/kWh	3,51	3,49	3,45	3,31	3,49	3,45	3,43	3,43	3,42
η <sub>s,h</sub> medium temperature <sup>(2) *</sup>	%	137,50	136,7	134,8	129,4	136,6	134,9	134,1	134,1	133,7
Nominal waterflow	l/h	4150	5148	7573	9228	10267	11951	13853	15095	17510
Power supply	V/Ph/Hz	400/3/50	400/3/50	400/3/50	400/3/50	400/3/50	400/3/50	400/3/50	400/3/50	400/3/50
Max input current standard unit	A	18,7	22,3	32,5	38,3	43,1	53,2	66,2	68,0	76,8
Peak current standard unit	A	61,1	81,4	117,5	147,7	140,2	167,2	207,7	209,0	209,0
Outdoor unit with single heat exchanger max airflow	m <sup>3</sup> /h	9000	9000	10000	16000	21000	21000	32000	32000	32000
Compressors / Circuits	n°/n°	2/1	2/1	2/1	2/1	2/1	2/1	2/1	2/1	2/1
Refrigerant		R410A	R410A	R410A	R410A	R410A	R410A	R410A	R410A	R410A
Global warming potential (GWP)		2088	2088	2088	2088	2088	2088	2088	2088	2088
Refrigerant charge <sup>(7)</sup>	kg	9,0	9,0	14,5	23,0	23,0	27,0	36,0	36,0	36,0
Equivalent CO <sub>2</sub> charge	t	18,79	18,79	30,27	48,02	48,02	56,37	75,16	75,16	75,16
Sound power indoor unit <sup>(4)</sup>	dB (A)	67	68	69	69	69	69	71	71	71
Sound pressure indoor unit <sup>(5)</sup>	dB (A)	51	52	53	53	53	53	54	54	54
Sound power outdoor unit - single heat exchanger <sup>(4)</sup>	dB (A)	69	69	70	--	--	--	--	--	--
Sound power outdoor unit - single heat exchanger <sup>(6)</sup>	dB (A)	37	37	38	--	--	--	--	--	--
Sound power outdoor unit - double heat exchanger <sup>(4)</sup>	dB (A)	--	--	--	70	70	70	72	72	72
Sound power outdoor unit - double heat exchanger <sup>(6)</sup>	dB (A)	--	--	--	38	38	38	40	40	40

### Reversible heating/cooling version (RV)

HE/NN/RV		262	312	462	512	612	762	862	1012	1212
Heating capacity (EN14511) <sup>(1) *</sup>	kW	24,1	29,9	44,0	53,7	59,7	69,5	80,5	87,8	101,8
Total input power (EN14511) <sup>(1) *</sup>	kW	5,0	6,4	9,0	11,9	12,5	15,1	17,4	19,0	22,9
COP (EN14511) <sup>(1) *</sup>	W/W	4,86	4,66	4,91	4,50	4,78	4,61	4,63	4,62	4,44
Energy Class in low temperature <sup>(2) *</sup>		A++	A++	A++	A++	A++	A++	A++	A++	A++
SCOP low temperature <sup>(2) *</sup>	kWh/kWh	4,36	4,22	4,17	3,87	4,23	4,19	4,12	4,16	4,06
η <sub>s,h</sub> low temperature <sup>(2) *</sup>	%	171,4	165,6	163,8	151,6	166,1	164,6	161,9	163,3	159,3
Energy Class in medium temperature <sup>(2) *</sup>		A++	A++	A++	A++	A++	A++	A++	A++	A++
SCOP medium temperature <sup>(2) *</sup>	kWh/kWh	3,51	3,49	3,45	3,31	3,49	3,45	3,43	3,43	3,42
η <sub>s,h</sub> medium temperature <sup>(2) *</sup>	%	137,50	136,7	134,8	129,4	136,6	134,9	134,1	134,1	133,7
Nominal waterflow	l/h	4150	5148	7573	9228	10267	11951	13853	15095	17510
Cooling capacity (EN14511) <sup>(3) *</sup>	kW	19,6	24,1	34,8	42,7	49,7	57,6	66,0	73,1	84,4
Total input power (EN14511) <sup>(3) *</sup>	kW	6,7	9,3	11,5	14,8	16,6	20,5	23,0	24,8	30,6
EER (EN14511) <sup>(3) *</sup>	W/W	2,93	2,59	3,04	2,89	3,00	2,81	2,87	2,95	2,76
Power supply	V/Ph/Hz	400/3/50	400/3/50	400/3/50	400/3/50	400/3/50	400/3/50	400/3/50	400/3/50	400/3/50
Max input current standard unit	A	18,7	22,3	32,5	38,3	43,1	53,2	66,2	68,0	76,8
Peak current standard unit	A	61,1	81,4	117,5	147,7	140,2	167,2	207,7	209,0	209,0
Outdoor unit with single heat exchanger max airflow	m <sup>3</sup> /h	9000	9000	10000	16000	21000	21000	32000	32000	32000
Compressors / Circuits	n°/n°	2/1	2/1	2/1	2/1	2/1	2/1	2/1	2/1	2/1
Refrigerant		R410A	R410A	R410A	R410A	R410A	R410A	R410A	R410A	R410A
Global warming potential (GWP)		2088	2088	2088	2088	2088	2088	2088	2088	2088
Refrigerant charge <sup>(7)</sup>	kg	9,0	9,0	14,5	23,0	23,0	27,0	36,0	36,0	36,0
Equivalent CO <sub>2</sub> charge	t	18,79	18,79	30,27	48,02	48,02	56,37	75,16	75,16	75,16
Sound power indoor unit <sup>(4)</sup>	dB (A)	67	68	69	69	69	69	71	71	71
Sound pressure indoor unit <sup>(5)</sup>	dB (A)	51	52	53	53	53	53	54	54	54
Sound power outdoor unit - single heat exchanger <sup>(4)</sup>	dB (A)	69	69	70	--	--	--	--	--	--
Sound power outdoor unit - single heat exchanger <sup>(6)</sup>	dB (A)	37	37	38	--	--	--	--	--	--
Sound power outdoor unit - double heat exchanger <sup>(4)</sup>	dB (A)	--	--	--	70	70	70	72	72	72
Sound power outdoor unit - double heat exchanger <sup>(6)</sup>	dB (A)	--	--	--	38	38	38	40	40	40

Performances are referred to the following conditions:

(1) Heating: Ambient temperature 7°C DB, 6°C WB, water temperature 30/35°C.

(2) Average conditions, variable - Reg EU 811/2013

(3) Cooling: ambient temperature 35°C, water temperature 12/7°C (RV versions only).

(4) Sound power level in accordance with ISO 3744.

(5) Sound pressure level at 1 mt from the unit in free field conditions, in accordance with ISO 3744.

(6) Sound pressure level at 10 mt from the unit in free field conditions, in accordance with ISO 3744.

(7) Without refrigerant lines content

\* Data referred to outdoor unit with single heat exchanger.

## COMPONENTS

### FRAME

All WZT units are made from hot-galvanised sheet steel, painted with polyurethane powder enamel and stoved at 180°C to provide maximum protection against corrosion. The frame is self-supporting with removable panels. All screws and rivets used are made from stainless steel. The standard colour of the units is RAL 9018.

### REFRIGERANT CIRCUIT

The refrigerant utilised is R410A. The refrigerant circuit is assembled using internationally recognised brand name components with all brazing and welding being performed in accordance with ISO 97/23. The refrigerant circuit includes: sight glass, filter drier, two thermal expansion valves (one for cooling mode, one for heating mode) with external equalizer, 4 way reversing valve, check valves, liquid receiver, Schrader valves for maintenance and control, pressure safety device (for compliance with PED regulations). The circuit also includes an AISI316 stainless steel heat exchanger that is used as an economizer plus an additional expansion valve for refrigerant vapour injection.

### COMPRESSORS

Scroll compressors equipped with E.V.I. technology, a versatile method of improving system capacity and efficiency. E.V.I. stands for "Economised Vapour Injection." The technology involves injecting refrigerant vapour into the middle of the compression process, a procedure that significantly boosts capacity and efficiency. Each scroll compressor used in these units is similar to a two-stage compressor with built-in inter-stage cooling. The process begins when a portion of the condenser liquid is extracted and expanded through an expansion valve. The low temperature liquid/gas mixture produced is injected into a heat exchanger that operates as a sub cooler. Any liquid is evaporated and the vapour produced is superheated.

The superheated vapour is then injected into an intermediate port in the scroll compressor. This cold vapour reduces the temperature of the compressed gas thus enabling the compressor to raise the pressure to levels (and temperatures) beyond that possible with a single stage scroll. The additional sub cooling of the main volume of liquid refrigerant increases the evaporator capacity. This compressor technology generates a larger pressure ratio between condensing and evaporating pressures, with significant performance improvement. The compressors are connected in tandem, they are all supplied with a crankcase heater and thermal overload protection by a klixon embedded in the motor winding. They are mounted in a separate enclosure in order to be separated from the air stream thus enabling them to be maintained even if the unit is operating. Access to this enclosure is by the front panel of the unit. The crankcase heater is always powered when the compressor is in stand-by.

### SOURCE HEAT EXCHANGER

The source heat exchanger is made from 3/8" copper pipes and 0.1mm thick aluminium fins with the tubes being mechanically expanded into the aluminium fins in order to maximise heat transfer. Furthermore, the design guarantees a low air side pressure drop thus enabling the use of low rotation speed (and hence low noise) fans.

### USER HEAT EXCHANGERS

The user heat exchanger is a braze welded, plate type heat exchanger, manufactured from AISI 316 stainless steel. Utilisation of this type of exchanger results in a massive reduction of the refrigerant charge of the unit compared to a traditional shell-in-tube type. A further advantage is a reduction in the overall dimensions of the unit.

The exchangers are factory insulated with flexible close cell material and can be fitted with an antifreeze heater (accessory). Each exchanger is fitted with a temperature sensor on the discharge water side for antifreeze protection.

### FANS

The fans are axial type with high performance aerofoil blades, the impeller is made of galvanized sheet galvanized, painted with polyurethane powder, to ensure a high protection in aggressive and severe environments. The impeller mounted directly on DC-brushless motor with external rotor, to ensure ideal cooling of the engine and a total absence of losses of the transmission. Impeller dynamically balanced in class 6.3 according to ISO 1940. Engine brushless-DC permanent magnet high efficiency electronic switching unit (driver) separate. Continuous speed variation with voltage signal 0-10 V, PFC integrated protection "burn out" (excessive drop in voltage), fully IP54 driver, serial interface with Modbus RTU communication protocol. The maximum rotation speed of the motor is 450 rpm to guarantee an extremely low noise level.

### MICROPROCESSORS

All units are supplied as standard with microprocessor controls. The microprocessor controls the following functions: control of the water temperature, antifreeze protection, compressor timing, compressor automatic starting sequence (For multiple compressors), alarm reset. The control panel is supplied with display showing all operational icons. The microprocessor is set for automatic defrost (when operating in severe ambient conditions) and for summer/winter change over. The control also manages the anti-legionella program, the integration with other heating sources (electric heaters, boilers, solar panels etc), the operation of a three port modulating valve (for diverting to DHW or heating) and both the heating circuit pump and the domestic hot water circuit pump. If required (available as an option), the microprocessor can be configured in order for it to connect to a site BMS system thus enabling remote control and management. The technical department can discuss and evaluate, in conjunction with the customer, solutions using MODBUS protocols.

### ELECTRIC ENCLOSURE

The enclosure is manufactured in order to comply with the requirements of the electromagnetic compatibility standards CEE EN60204. Access to the enclosure is achieved by removing the front panel of the unit. The following components are supplied as standard on all units: main switch, thermal overloads (protection of pumps and fans), compressor fuses, control circuit automatic breakers, compressor contactors, fan contactors and pump contactors.

The terminal board has volt free contacts for remote ON-OFF, Summer/Winter change over and general alarm.

For all three phase units, a sequence relay that disables the power supply in the event that the phase sequence is incorrect (scroll compressors can be damaged if they rotate in the wrong direction), is fitted as standard.

valve, compressor thermal overload protection, fans thermal overload protection, pressure transducer (used to optimize the defrost cycle and the fan speed depending on the ambient conditions), flow switch.

### CONTROL AND PROTECTION DEVICES

All units are supplied with the following control and protection devices: Return user water temperature sensor, antifreeze protection sensor installed on the user outlet water temperature, return and supply, high pressure switch with manual reset, low pressure switch with automatic reset, high pressure safety

## VERSIONS

### P2U Version

This is a two pipe version that can produce hot water for heating and cold water for cooling. The unit is used with two pipe water based change-over systems. It is not able to produce domestic hot water.

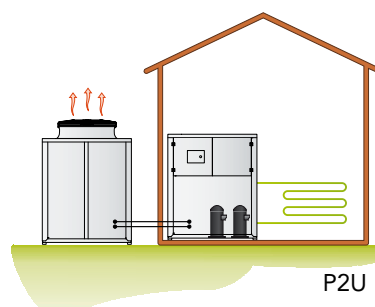

### P2S Version

This is a two pipe version that can, in addition to producing hot water for heating and cold water for cooling, also generate domestic hot water. The controller has dual heating set points (heating and DHW) and can also control a three port diverting valve that directs the DHW to the cylinder. DHW production has priority irrespective of the mode of operation of the unit. The unit is normally used with two pipe water based change-over systems.

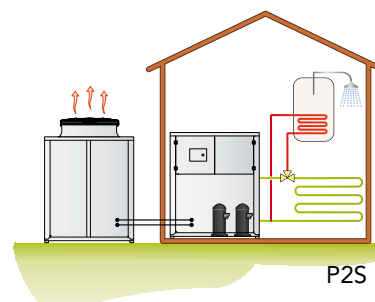

### P4S Version

This is a four pipe version that can produce hot water for heating, cold water for cooling and domestic hot water in all operational modes using an independent water circuit. When cooling, DHW generation is by heat recovery. This unit is normally used with two pipe water based change-over systems with the DHW circuit being separate.

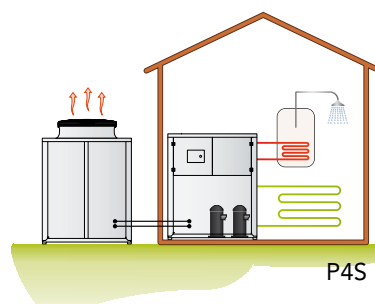

### P4U Version

This is a four pipe version that provides a modern approach to four pipe water based systems. Instead of using a boiler and chiller, this unit can generate hot water in one circuit, cold water in the other circuit either individually or simultaneously. When operating in simultaneous mode the heating capacity is equal to the cooling duty plus the power input to the compressors. The operating efficiency in this mode is extremely high. Domestic hot water production for this version is not available.

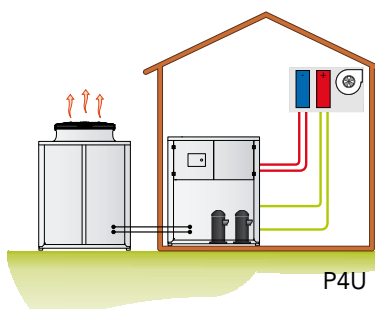

### Noise Reduction

All units are supplied, as standard, with the latest 'Floating Frame' technology that completely isolates the compressors from the main casing, thereby eliminating vibration and noise from this source. The 'Floating Frame' is a special vibration and acoustic damping system that consists of a base plate and acoustic enclosure that houses the compressors. The base plate is separated from the supporting frame of the unit by soft steel springs that have a high damping power. Within the enclosure, the compressors are mounted on rubber shock absorbers on the floating base plate. The enclosure is manufactured from galvanized steel sandwich panels that have a micro-perforated inner skin and a core of 30 mm thick, high density (25 kg/m<sup>3</sup>). The entire arrangement provides a double damping system and acoustic attenuation. The compressor refrigerant pipes are connected to the refrigerant circuit through "anaconda" flexible connections. Flexible connections are also used on the water pipework within the unit. The combination of these systems results in an overall noise reduction in the region of 6-8 dB(A).

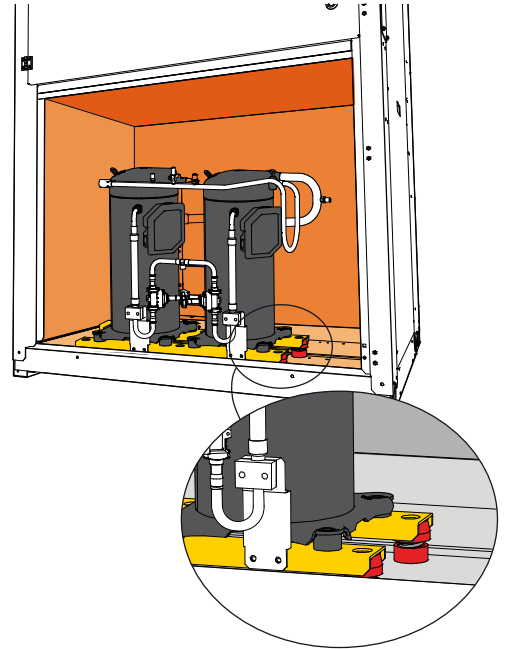

### OPERATION LIMITS

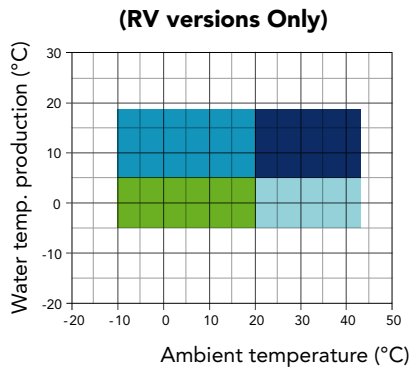
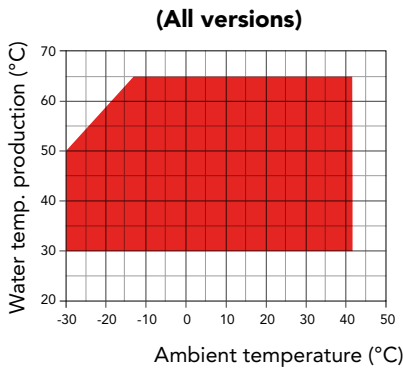

- Heating mode
- Cooling with head pressure control
- Cooling mode
- Cooling with head pressure control and glycol
- Cooling with glycol

### ACCESSORIES

WZT/NN		262	312	462	512	612	762	862	1012	1212
Main switch		●	●	●	●	●	●	●	●	●
Compressor automatic switch		●	●	●	●	●	●	●	●	●
Flow switch		●	●	●	●	●	●	●	●	●
Evap/cond pressure control by transducer and fan speed control		●	●	●	●	●	●	●	●	●
Fresh air temperature probe for set-point compensation		●	●	●	●	●	●	●	●	●
Specific software for operation priorities		●	●	●	●	●	●	●	●	●
Remote ON/OFF digital input		●	●	●	●	●	●	●	●	●
Summer/Winter digital input		●	●	●	●	●	●	●	●	●
Floating frame technology		●	●	●	●	●	●	●	●	●
Condensate tray with anti-freeze heater (outdoor section)	<b>BRCA</b>	●	●	●	●	●	●	●	●	●
E.C. fans - HE versions	<b>VECE</b>	●	●	●	●	●	●	●	●	●
Cascade control system via RS485	<b>SGRS</b>	○	○	○	○	○	○	○	○	○
Rubber anti-vibration mountings	<b>KAVG</b>	○	○	○	○	○	○	○	○	○
Evaporator antifreeze heater	<b>RAEV2/4</b>	○	○	○	○	○	○	○	○	○
Electronic soft starter	<b>DSSE</b>	○	○	○	○	○	○	○	○	○
Remote control panel	<b>PCRL</b>	○	○	○	○	○	○	○	○	○
Serial interface card RS485	<b>INSE</b>	●	●	●	●	●	●	●	●	●
Electronic thermostatic valve	<b>VTEE</b>	○	○	○	○	○	○	○	○	○

● Standard, ○ Optional, – Not Available.

**WZT - Indoor unit**

Mod.	A(mm)	B(mm)	C(mm)	kg
262	1600	800	1150	510
312	1600	800	1150	515
462	1600	800	1150	535
512	1600	800	1150	560
612	1600	800	1150	580
762	1600	800	1150	585
862	1600	800	1150	590
1012	1600	800	1150	600
1212	1600	800	1150	600

**Matching with outdoor unit**

Mod.
1
2
3
4
4
5
5
6
6

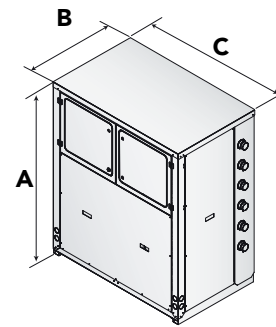

**EVV - Outdoor unit with single heat exchanger and vertical airflow**

Mod.	Fans (n°)	A(mm)	B(mm)	C(mm)	kg
1	2	1680	1615	875	242
2	2	1680	1615	875	263
3	2	1880	2115	1145	310

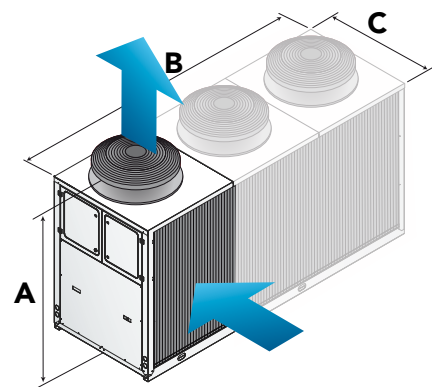

**EVR - Outdoor unit with double heat exchanger and vertical airflow**

Mod.	Fans (n°)	A(mm)	B(mm)	C(mm)	kg
4	2	1880	2115	1145	406
5	2	1880	2115	1145	425
6	3	1880	3115	1145	406

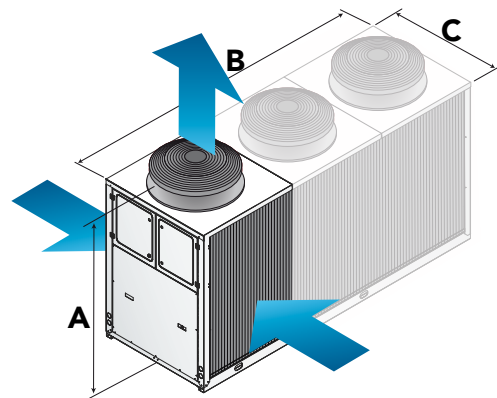

# WZA

## GROUND SOURCE WATER TO WATER HEAT PUMPS EQUIPPED WITH SCROLL COMPRESSOR

Heating capacity from 7 kW to 45 kW

R410A

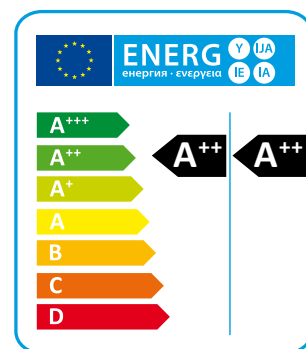

WZA heat pumps are particularly suitable for applications that utilise well water or ground source probes. These units have been designed for use with radiant heating systems or those applications where it is necessary to have maximum efficiency when heating. They have been optimized on heating mode and are able to produce water up to 60°C.

WZA heat pumps are available in several versions. The most simple is a 2 pipe unit that can provide heating only. By fitting an external 3 port valve the unit can provide either heating or domestic hot water. There is also a 4 pipe unit that produces domestic hot water in a separate hydraulic circuit and can generate this irrespective of whether the unit is in heating or cooling mode.

Differing versions and a wide range of accessories, enable the optimal solution to be selected.

### VERSIONS

- HH** Standard, heating only.
- RV** Reversible heating/cooling.
- P2U** 2 pipe systems without domestic hot water production.
- P4S** 2+2 pipe systems with domestic hot water production.
- PO** Unit designed for well water.
- GE** Unit designed for geothermal probe.

## TECHNICAL DATA

WZA - WZA/RV		06	08	12	16	20	24	33	40
Heating capacity (EN14511) <sup>(1)</sup>	kW	7,7	9,9	13,6	17,2	22,8	26,9	34,0	44,7
Input power (EN14511) <sup>(1)</sup>	kW	1,3	1,6	2,1	2,7	3,8	4,3	5,6	7,7
COP (EN14511) <sup>(1)</sup>	W/W	5,89	6,06	6,26	6,18	6,01	6,13	6,06	5,77
Energy Class in low temperature <sup>(2)</sup>		A++	A++	A++	A++	A++	A++	A++	A++
SCOP low temperature <sup>(2)</sup>	kWh/kWh	5,41	5,68	5,66	5,67	5,69	6,07	6,03	5,79
η <sub>s,h</sub> low temperature <sup>(2)</sup>	%	208,4	219,2	218,3	218,8	219,7	234,8	233,0	223,4
Energy Class in medium temperature <sup>(2)</sup>		A++	A++	A++	A++	A++	A++	A++	A++
SCOP medium temperature <sup>(2)</sup>	kWh/kWh	4,21	4,31	4,38	4,44	4,39	4,80	4,82	4,69
η <sub>s,h</sub> medium temperature <sup>(2)</sup>	%	160,5	164,4	167,1	169,6	167,6	184,1	184,9	179,4
Cooling capacity (EN14511) <sup>(3)</sup>	kW	5,5	7,1	9,9	12,6	16,7	19,8	25,3	33,4
Input power (EN14511) <sup>(3)</sup>	kW	1,4	1,8	2,4	3,0	4,1	4,8	6,0	8,2
EER (EN14511) <sup>(3)</sup>	W/W	3,78	3,88	4,14	4,16	4,06	4,13	4,16	4,04
Power supply	V/Ph/Hz	230/1/50	230/1/50	230/1/50	400/3+N/50	400/3+N/50	400/3+N/50	400/3+N/50	400/3+N/50
Peak current	A	60,0	83,0	51,5	62,0	75,0	58,9	71,7	88,0
Maximum input current	A	12,8	17,1	7,4	9,7	13,0	14,8	19,4	26,0
Compressors / Circuits	n°/n°	1 / 1	1 / 1	1 / 1	1 / 1	1 / 1	2 / 1	2 / 1	2 / 1
Refrigerant		R410A	R410A	R410A	R410A	R410A	R410A	R410A	R410A
Global warming potential (GWP)		2088	2088	2088	2088	2088	2088	2088	2088
Refrigerant charge	kg	2,2	2,2	2,9	2,9	4,6	4,6	5,0	5,5
Equivalent CO <sub>2</sub> charge	t	4,6	4,6	6,0	6,0	9,6	9,6	10,4	11,4
Sound power <sup>(4)</sup>	dB (A)	62	63	65	67	69	71	75	77
Sound pressure <sup>(5)</sup>	dB (A)	48	49	50	52	54	56	60	62

Performances are referred to the following conditions:

(1) Heating: User water temperature 30/35°C; Source water temperature 10/7°C.

(2) Variable - Reg EU 811/2013

(3) Cooling: User water temperature 12/7°C, Source water temperature 30/35°C.

(4) Sound power level in accordance with ISO 3744.

(5) Sound pressure level at 1 mt from the unit in free field conditions in accordance with ISO 3744.

## COMPONENTS

### FRAME

All units are made from hot-galvanised sheet steel, painted with polyurethane powder enamel and stoved at 180°C to provide maximum protection against corrosion. The frame is self-supporting with removable panels. All screws and rivets used are made from stainless steel.

### REFRIGERANT CIRCUIT

The refrigerant utilised is R410A. The refrigerant circuit is assembled using internationally recognised brand name components with all brazing and welding being performed in accordance with ISO 97/23. Each refrigerant circuit is totally independent from the other with the result that any fault or alarm condition on one circuit does not influence the other. The refrigerant circuit includes: sight glass, filter drier, electronic expansion valve, Schrader valves for maintenance and control and pressure safety device (for compliance with PED regulations).

### COMPRESSORS

The compressors used are a high performance scroll type that incorporates a special scroll design which enhances the efficiency of the refrigerant cycle when the source temperature is low. The compressors are all supplied with a crankcase heater and thermal overload protection by a klixon embedded in the motor winding. They are mounted in a separate enclosure thus enabling them to be maintained even if the unit is operating. Access

to this enclosure is via the front panel of the unit. The crankcase heater is always powered when the compressor is in stand-by.

### SOURCE SIDE HEAT EXCHANGERS

The source side heat exchanger is a braze welded, plate type heat exchanger, manufactured from AISI 316 stainless steel. It has a single water side circuit. Utilisation of this type of exchanger results in a massive reduction of the refrigerant charge of the unit compared to a traditional shell-in-tube type and increases the efficiency of the refrigerant cycle at part loads. The source heat exchangers are factory insulated with flexible close cell material and are provided with a temperature sensor for antifreeze protection.

### USER SIDE HEAT EXCHANGERS

The user side heat exchanger is a braze welded, plate type heat exchanger, manufactured from AISI 316 stainless steel. It has a single water side circuit. All units are supplied with a sub-cooler to enhance the performance of the refrigerant cycle. The user heat exchangers are factory insulated with flexible close cell material.

### MICROPROCESSORS

All units are supplied as standard with microprocessor controls. The microprocessor controls the following functions: control of the water temperature, antifreeze protection, compressor timing, compressor automatic starting sequence, alarm reset, volt free contact for remote general alarm, alarms and op-

eration LED's. If required (available as an option), the microprocessor can be configured in order for it to connect to a site BMS system thus enabling remote control and management. The Hydros technical department can discuss and evaluate, in conjunction with the customer, solutions using MODBUS protocols.

**ELECTRIC ENCLOSURE**

The enclosure is manufactured in order to comply with the requirements of the electromagnetic compatibility standards CEE EN60204. Access to the enclosure is achieved by removing the front panel of the unit. The following components are supplied as standard on all units: main switch, thermal overloads (protection of pumps), compressor fuses, control circuit automatic breakers, compressor contactors, fan contactors and pumps contactors.

The terminal board has volt free contacts for remote ON-OFF, Summer/Winter change over (reversible type only) and general alarm. For all three phase units, a sequence relay that disables the power supply in the event that the phase sequence is incorrect (scroll compressors can be damaged if they rotate in the wrong direction), is fitted as standard.

**CONTROL AND PROTECTION DEVICES**

All units are supplied with the following control and protection devices: Return and supply user heat exchanger sensors, return and supply source heat exchanger sensors, high pressure switch with manual reset, low pressure switch with automatic reset, high pressure safety valve, compressor thermal overload protection,

pump thermal overload protection, high and low pressure transducers, differential pressure switch on source and user circuit.

**HYDRAULIC KIT**

All units are supplied as standard with built-in hydraulic kit so configured:

User circuit: includes the inverter water pump, expansion vessel, filling connection, water drain and the water flow safety device (differential pressure switch). Source circuit: includes the inverter water pump, the water flow safety device (differential pressure switch), filling connection, water drain and expansion vessel. Domestic hot water circuit: includes the inverter water pump controlled by the microprocessor.

**ELECTRONIC THERMOSTATIC VALVE**

All the units are equipped with an electronic thermostatic valve, in order to optimise the functioning of the cooling circuit and to maximise the energy efficiency of the system in all operating conditions that can be implemented on the system.

**VERSIONS**

**WZA/HH**

Version for heating only applications.

**WZA/RV 2 pipes version**

This version is capable of cooling during summer operation by using a 4 way reversing valve in the refrigerant circuit.

**WZA/RV/P4S 4 pipes version**

This version is supplied with 4 pipes on the user side and is able to produce simultaneously, hot and cold water on 2 independent hydraulic circuits. On this version, the domestic hot water.

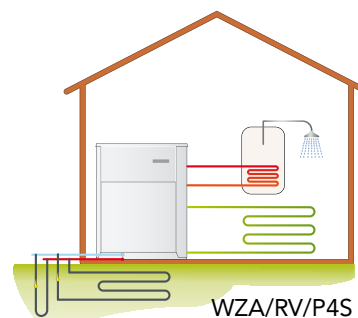
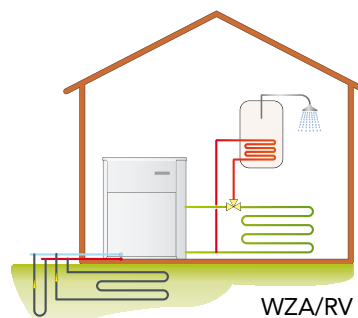

## ACCESSORIES

WZA - WZA/RV		06	08	12	16	20	24	33	40
Main switch		●	●	●	●	●	●	●	●
Microprocessor control		●	●	●	●	●	●	●	●
Water pumps ( source, user, domestic hot water pump)		●	●	●	●	●	●	●	●
Low noise version LS [-4dB(A) of STD]	LS00	○	○	○	○	○	○	○	○
Electronic soft starter	DSSE	-	-	-	○	○	○	○	○
Rubber anti-vibration mountings	KAVG	●	●	●	●	●	●	●	●
Remote control panel	PCRL	○	○	○	○	○	○	○	○
Serial interface card RS485	INSE	○	○	○	○	○	○	○	○

● Standard, ○ Optional, - Not available.

WZA

## OPERATION LIMITS

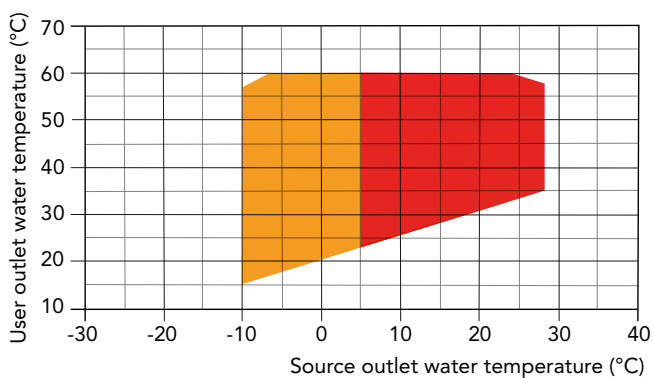

- Heating
- Heating with glycol source circuit

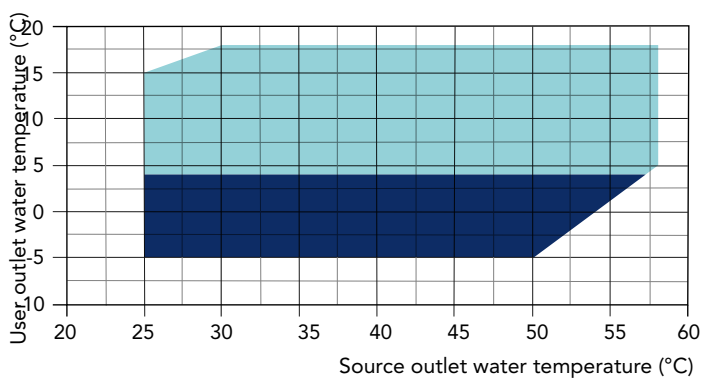

- Cooling
- Cooling with glycol user circuit

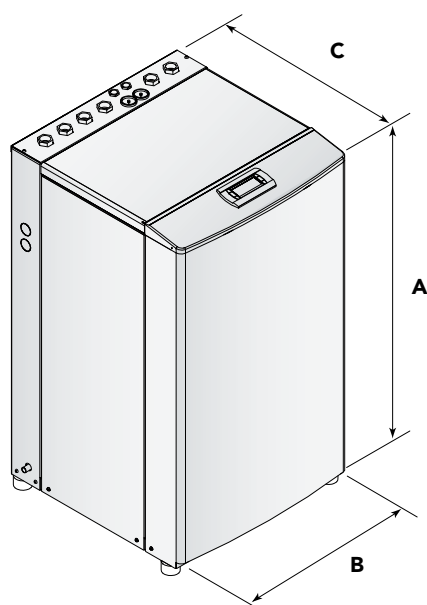

Mod.	A (mm)	B (mm)	C (mm)	kg
06	970	620	575	146
08	970	620	575	153
12	1050	620	650	169
16	1050	620	650	195
20	1050	620	650	215
24	1040	800	880	262
33	1040	800	880	302
40	1040	800	880	320

Heating capacity from 52 kW to 440 kW

R410A

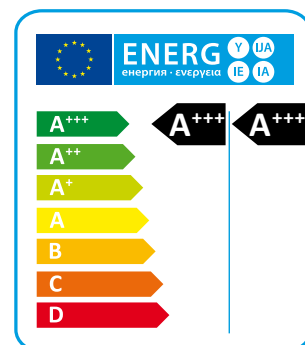

WHA heat pumps are particularly suitable for applications that utilise ground source probes. These units have been designed for use with radiant floor heating systems or those applications where it is necessary to have maximum efficiency when heating. They have been optimized on heating mode and are able to produce water up to 60°C. WHA heat pumps are available in several versions. The most simple is a 2 pipe unit that can provide heating only. By fitting an external 3 port valve the unit can provide either heating or domestic hot water. There is also a 4 pipe unit that produces domestic hot water in a separate hydraulic circuit and can generate this irrespective of whether the unit is in heating or cooling mode. All the WHA units are also available in Free Cooling (FC) versions which provide low energy cooling by simply using the cool water that is available from either the ground source probes or the well water.

Differing versions and a wide range of accessories, enable the optimal solution to be selected.

### VERSIONS

- Standard, heating only.
- RV** Reversible heating/cooling.
- SW5** Heating only + domestic hot water circuit.
- RV/SW6** Reversible version heating/cooling with independent DHW circuit.
- FC** Free cooling version (available in all versions).

## TECHNICAL DATA

Heating only version (HH)

HH		039	045	050	060	070	080	090	110	120
Heating capacity (EN14511) <sup>(1)</sup>	kW	51,7	59,0	71,2	80,0	92,5	105,9	120,8	136,1	152,0
Input power (EN14511) <sup>(1)</sup>	kW	9,8	11,0	12,5	14,3	16,9	19,4	22,2	24,9	28,3
COP (EN14511) <sup>(1)</sup>	W/W	5,27	5,36	5,69	5,59	5,47	5,45	5,44	5,46	5,37
Energy Class in low temperature <sup>(2)</sup>		A+++	A+++	A+++	A+++	A+++	A+++	A+++	A+++	A+++
SCOP low temperature <sup>(2)</sup>	kWh/kWh	5,21	5,52	5,51	5,77	5,60	5,50	5,44	5,44	5,46
$\eta_{s,h}$ low temperature <sup>(2)</sup>	%	200,4	212,8	212,5	222,9	215,8	212,0	209,4	209,5	210,5
Energy Class in medium temperature <sup>(2)</sup>		A+++	A+++	A+++	A+++	A+++	A+++	A+++	A+++	A+++
SCOP medium temperature <sup>(2)</sup>	kWh/kWh	4,32	4,50	4,51	4,67	4,54	4,51	4,45	4,47	4,48
$\eta_{s,h}$ medium temperature <sup>(2)</sup>	%	164,6	171,8	172,4	178,6	173,4	172,4	170,0	170,8	171,1
Power supply	V/Ph/Hz	400/3/50	400/3/50	400/3/50	400/3/50	400/3/50	400/3/50	400/3/50	400/3/50	400/3/50
Peak current	A	111,0	132,0	140,0	143,0	199,0	208,0	259,0	265,0	312,0
Max input current	A	32,0	42,0	44,0	50,0	59,0	68,0	74,0	80,0	88,5
Compressors / Circuits	n°/n°	2/1	2/1	2/1	2/1	2/1	2/1	2/1	2/1	2/1
Capacity steps	n°	2	2	2	2	2	2	2	2	2
Refrigerant		R410A	R410A	R410A	R410A	R410A	R410A	R410A	R410A	R410A
Global warming potential (GWP)		2088	2088	2088	2088	2088	2088	2088	2088	2088
Refrigerant charge	kg	4,3	4,3	5,0	5,0	6,0	6,5	8,0	11,0	11,0
Equivalent CO <sub>2</sub> charge	t	9,0	9,0	10,4	10,4	12,5	13,6	16,7	23,0	23,0
Sound power <sup>(4)</sup>	dB(A)	71	77	77	78	79	80	83	85	87
Sound pressure <sup>(5)</sup>	dB(A)	55	61	61	62	63	64	66	68	70

HH		130	152	162	190	210	240	260	300	320
Heating capacity (EN14511) <sup>(1)</sup>	kW	169,2	195,0	222,1	243,8	271,3	306,9	342,2	390,9	439,4
Input power (EN14511) <sup>(1)</sup>	kW	31,6	36,8	41,0	45,1	51,0	57,3	63,6	72,5	81,4
COP (EN14511) <sup>(1)</sup>	W/W	5,35	5,29	5,41	5,40	5,32	5,35	5,38	5,39	5,39
Energy Class in low temperature <sup>(2)</sup>		A+++	A+++	A+++	A+++	A+++	A+++	A+++	A+++	A+++
SCOP low temperature <sup>(2)</sup>	kWh/kWh	5,42	5,49	5,64	5,47	5,45	5,47	5,51	5,55	5,49
$\eta_{s,h}$ low temperature <sup>(2)</sup>	%	208,8	211,7	217,6	210,6	209,9	210,6	212,5	214,1	211,6
Energy Class in medium temperature <sup>(2)</sup>		A+++	A+++	A+++	A+++	A+++	A+++	A+++	A+++	A+++
SCOP medium temperature <sup>(2)</sup>	kWh/kWh	4,50	4,53	4,62	4,53	4,54	4,55	4,58	4,60	4,59
$\eta_{s,h}$ medium temperature <sup>(2)</sup>	%	171,8	173,0	176,7	173,2	173,5	173,9	175,0	175,8	175,4
Power supply	V/Ph/Hz	400/3/50	400/3/50	400/3/50	400/3/50	400/3/50	400/3/50	400/3/50	400/3/50	400/3/50
Peak current	A	320,5	358,5	375,4	333,0	345,0	400,5	417,5	472,4	506,2
Max input current	A	97,0	113,9	130,8	148,0	160,0	177,0	194,0	227,8	261,6
Compressors / Circuits	n°/n°	2/1	2/1	2/1	4/2	4/2	4/2	4/2	4/2	4/2
Capacity steps	n°	2	2	2	4	4	4	4	4	4
Refrigerant		R410A	R410A	R410A	R410A	R410A	R410A	R410A	R410A	R410A
Global warming potential (GWP)		2088	2088	2088	2088	2088	2088	2088	2088	2088
Refrigerant charge	kg	15,0	15,0	15,0	16,0	16,0	19,0	19,0	30,0	30,0
Equivalent CO <sub>2</sub> charge	t	31,3	31,3	31,3	33,4	33,4	39,7	39,7	62,6	62,6
Sound power <sup>(4)</sup>	dB(A)	88	88	88	86	88	90	91	91	91
Sound pressure <sup>(5)</sup>	dB(A)	71	71	71	69	71	73	74	74	74

Performances are referred to the following conditions:

(1) Heating: user water temperature 30/35°C, source water temperature 10/7°C.

(2) Average conditions, variable - Reg EU 811/2013

(3) Sound power level in accordance with ISO 3744. Operation mode 1, without water pumps.

(4) Sound pressure level at 1 mt from the unit in free field conditions in accordance with ISO 3744. Operation mode 1, without water pumps.

Reversible heating/cooling version (RV)

RV		039	045	050	060	070	080	090	110	120
Heating capacity (EN14511) <sup>(1)</sup>	kW	51,7	59,0	71,2	80,0	92,5	105,9	120,8	136,1	152,0
Input power (EN14511) <sup>(1)</sup>	kW	9,8	11,0	12,5	14,3	16,9	19,4	22,2	24,9	28,3
COP (EN14511) <sup>(1)</sup>	W/W	5,27	5,36	5,69	5,59	5,47	5,45	5,44	5,46	5,37
Energy Class in low temperature <sup>(2)</sup>		A+++	A+++	A+++	A+++	A+++	A+++	A+++	A+++	A+++
SCOP low temperature <sup>(2)</sup>	kWh/kWh	5,21	5,52	5,51	5,77	5,60	5,50	5,44	5,44	5,46
$\eta_{s,h}$ low temperature <sup>(2)</sup>	%	200,4	212,8	212,5	222,9	215,8	212,0	209,4	209,5	210,5
Energy Class in medium temperature <sup>(2)</sup>		A+++	A+++	A+++	A+++	A+++	A+++	A+++	A+++	A+++
SCOP medium temperature <sup>(2)</sup>	kWh/kWh	4,32	4,50	4,51	4,67	4,54	4,51	4,45	4,47	4,48
$\eta_{s,h}$ medium temperature <sup>(2)</sup>	%	164,6	171,8	172,4	178,6	173,4	172,4	170,0	170,8	171,1
Cooling capacity (EN14511) <sup>(3)</sup>	kW	42,9	49,0	60,3	67,4	77,5	88,9	101,3	114,3	126,9
Total input power (EN14511) <sup>(3)</sup>	kW	10,0	11,3	12,9	14,7	17,4	19,9	22,7	25,5	29,0
EER (EN14511) <sup>(3)</sup>	W/W	4,29	4,33	4,67	4,58	4,45	4,46	4,46	4,48	4,37
Free Cooling capacity <sup>(4)</sup>	kW	22,8	22,9	36,0	36,3	36,6	49,3	71,0	72,4	73,5
Power supply	V/Ph/Hz	400/3/50	400/3/50	400/3/50	400/3/50	400/3/50	400/3/50	400/3/50	400/3/50	400/3/50
Peak current	A	111,0	132,0	140,0	143,0	199,0	208,0	259,0	265,0	312,0
Max input current	A	32,0	42,0	44,0	50,0	59,0	68,0	74,0	80,0	88,5
Compressors / Circuits	n°/n°	2/1	2/1	2/1	2/1	2/1	2/1	2/1	2/1	2/1
Capacity steps	n°	2	2	2	2	2	2	2	2	2
Refrigerant		R410A	R410A	R410A	R410A	R410A	R410A	R410A	R410A	R410A
Global warming potential (GWP)		2088	2088	2088	2088	2088	2088	2088	2088	2088
Refrigerant charge	kg	5,0	5,0	7,0	7,0	7,5	9,0	10,0	15,0	15,0
Equivalent CO <sub>2</sub> charge	t	10,4	10,4	14,6	14,6	15,7	18,8	20,9	31,3	31,3
Sound power <sup>(5)</sup>	dB(A)	71	77	77	78	79	80	83	85	87
Sound pressure <sup>(6)</sup>	dB(A)	55	61	61	62	63	64	66	68	70

RV		130	152	162	190	210	240	260	300	320
Heating capacity (EN14511) <sup>(1)</sup>	kW	169,2	195,0	222,1	243,8	271,3	306,9	342,2	390,9	439,4
Input power (EN14511) <sup>(1)</sup>	kW	31,6	36,8	41,0	45,1	51,0	57,3	63,6	72,5	81,4
COP (EN14511) <sup>(1)</sup>	W/W	5,35	5,29	5,41	5,40	5,32	5,35	5,38	5,39	5,39
Energy Class in low temperature <sup>(2)</sup>		A+++	A+++	A+++	A+++	A+++	A+++	A+++	A+++	A+++
SCOP low temperature <sup>(2)</sup>	kWh/kWh	5,42	5,49	5,64	5,47	5,45	5,47	5,51	5,55	5,49
$\eta_{s,h}$ low temperature <sup>(2)</sup>	%	208,8	211,7	217,6	210,6	209,9	210,6	212,5	214,1	211,6
Energy Class in medium temperature <sup>(2)</sup>		A+++	A+++	A+++	A+++	A+++	A+++	A+++	A+++	A+++
SCOP medium temperature <sup>(2)</sup>	kWh/kWh	4,50	4,53	4,62	4,53	4,54	4,55	4,58	4,60	4,59
$\eta_{s,h}$ medium temperature <sup>(2)</sup>	%	171,8	173,0	176,7	173,2	173,5	173,9	175,0	175,8	175,4
Cooling capacity (EN14511) <sup>(3)</sup>	kW	141,2	163,6	187,4	205,1	226,9	257,3	287,4	328,1	368,5
Total input power (EN14511) <sup>(3)</sup>	kW	32,3	37,8	42,2	46,3	52,4	58,8	65,2	74,3	83,4
EER (EN14511) <sup>(3)</sup>	W/W	4,37	4,32	4,44	4,43	4,33	4,37	4,40	4,41	4,41
Free Cooling capacity <sup>(4)</sup>	kW	74,1	93,1	94,0	128,2	129,6	130,9	163,0	164,4	203,0
Power supply	V/Ph/Hz	400/3/50	400/3/50	400/3/50	400/3/50	400/3/50	400/3/50	400/3/50	400/3/50	400/3/50
Peak current	A	320,5	358,5	375,4	333,0	345,0	400,5	417,5	472,4	506,2
Max input current	A	97,0	113,9	130,8	148,0	160,0	177,0	194,0	227,8	261,6
Compressors / Circuits	n°/n°	2/1	2/1	2/1	4/2	4/2	4/2	4/2	4/2	4/2
Capacity steps	n°	2	2	2	4	4	4	4	4	4
Refrigerant		R410A	R410A	R410A	R410A	R410A	R410A	R410A	R410A	R410A
Global warming potential (GWP)		2088	2088	2088	2088	2088	2088	2088	2088	2088
Refrigerant charge	kg	15,0	15,0	15,0	20,0	20,0	30,0	30,0	34,0	34,0
Equivalent CO <sub>2</sub> charge	t	31,3	31,3	31,3	41,8	41,8	62,6	62,6	71,0	71,0
Sound power <sup>(5)</sup>	dB(A)	88	88	88	86	88	90	91	91	91
Sound pressure <sup>(6)</sup>	dB(A)	71	71	71	69	71	73	74	74	74

Performances are referred to the following conditions:

(1) Heating: user water temperature 30/35°C, source water temperature 10/7°C.

(2) Average conditions, variable - Reg EU 811/2013

(3) Cooling: user water temperature 12/7°C, source water temperature 30/35°C.

(4) Free Cooling: user water temperature 10°C, source water temperature 20°C, compressors OFF.

(5) Sound power level in accordance with ISO 3744. Operation mode 1, without water pumps.

(6) Sound pressure level at 1 mt from the unit in free field conditions in accordance with ISO 3744. Operation mode 1, without water pumps.

## COMPONENTS

### FRAME

All units are made from hot-galvanised sheet steel, painted with polyurethane powder enamel and stoved at 180°C to provide maximum protection against corrosion. The frame is self-supporting with removable panels. All screws and rivets used are made from stainless steel. The standard colour of the units is RAL 9018.

### REFRIGERANT CIRCUIT

The refrigerant utilised is R410A. The refrigerant circuit is assembled using internationally recognised brand name components with all brazing and welding being performed in accordance with ISO 97/23. Each refrigerant circuit is totally independent from the other with the result that any fault or alarm condition on one circuit does not influence the other.

The refrigerant circuit includes: sight glass, filter drier, thermal expansion valve with external equalizer, Schrader valves for maintenance and control and pressure safety device (for compliance with PED regulations).

### COMPRESSORS

The compressors used are a high performance scroll type that incorporates a special scroll design which enhances the efficiency of the refrigerant cycle when the source temperature is low. The compressors are all supplied with a crankcase heater and thermal overload protection by a klixon embedded in the motor winding. They are mounted in a separate enclosure thus enabling them to be maintained even if the unit is operating. Access to this enclosure is via the front panel of the unit. The crankcase heater is always powered when the compressor is in stand-by.

### SOURCE HEAT EXCHANGER

Source heat exchanger are braze-welded plates and are made of stainless steel AISI 316. From size 039 to size 162 are single-circuit, from size 190 are all double circuit cross-flow. The use of this type of exchangers greatly reduces the refrigerant charge of the unit compared to the conventional shell and tube evaporators, and increases the efficiency of the refrigerant loads. The heat exchangers are factory insulated with flexible close cell material and are protected by a temperature sensor used as antifreeze protection kit.

### USER EXCHANGER

The user side heat exchanger is a braze welded, plate type heat exchanger, manufactured from AISI 316 stainless steel. From size 039 to size 162 they have a single water side circuit, from the size 190 they are double circuit, "cross flow" type. All units are supplied with a sub-cooler to enhance the performance of the refrigerant cycle. The user heat exchangers are factory insulated with flexible close cell material.

### MICROPROCESSORS

All units are supplied as standard with microprocessor controls. The microprocessor controls the following functions: control of the water temperature, antifreeze protection, compressor timing, compressor automatic starting sequence, alarm reset, volt free contact for remote general alarm, alarms and operation LED's. If required (available as an option), the microprocessor can be configured in order for it to connect to a site BMS system thus enabling remote control and management. The technical department can discuss and evaluate, in conjunction with the customer, solutions using MODBUS protocols.

### ELECTRIC ENCLOSURE

The enclosure is manufactured in order to comply with the requirements of the electromagnetic compatibility standards CEE EN60204. Access to the enclosure is achieved by removing the front panel of the unit. The following components are supplied as standard on all units: main switch, thermal overloads (protection of pumps and fans), compressor fuses, control circuit automatic breakers, compressor contactors, fan contactors and pump contactors. The terminal board has volt free contacts for remote ON-OFF, Summer/Winter change over (reversible type only) and general alarm. For all three phase units, a sequence relay that disables the power supply in the event that the phase sequence is incorrect (scroll compressors can be damaged if they rotate in the wrong direction), is fitted as standard.

### CONTROL AND PROTECTION DEVICES

All units are supplied with the following control and protection devices: Return and supply user heat exchanger sensors, return and supply source heat exchanger sensors, high pressure switch with manual reset, low pressure switch with automatic reset, high pressure safety valve, compressor thermal overload protection, pump thermal overload protection (when present), source heat exchanger flow switch.



### HYDRAULIC KIT

all units can be supplied with water pump circulation kit installed on Source, User or Recovery circuit.

## VERSIONS

### WHA/RV 2 Pipe version

This version is capable of cooling during summer operation by using a 4 way reversing valve in the refrigerant circuit.

### WHA/RV/SW6 4 Pipe version

This version has 4 pipes on the user side and is able to produce simultaneously, hot and cold water on 2 independent hydraulic circuits. The domestic hot water production is independent of the operation mode of the unit.

### Versione free cooling

These versions, in addition to the characteristics described above, can produce cold water during summer operation using the cold water available from the source ground probes. All free cooling versions are supplied with an intermediate heat exchanger and a 3 way valve which modulates the water flow to the user circuit depending on the required user cold water temperature. During free cooling mode the compressors may be off or will operate partially to augment the free cooling available.

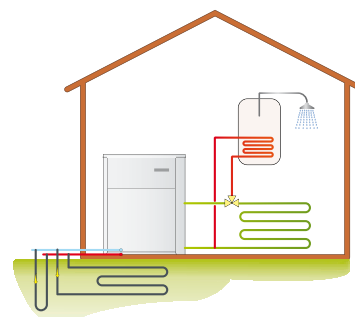

WHA/RV

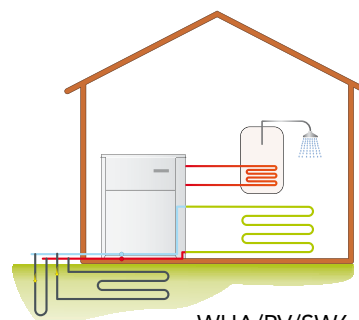

WHA/RV/SW6

## CONFIGURATIONS \*

MOD.	P2	P4	P2+FC	P4+FC	P2+A	P4+A
39	F1	F1	F1	F1	F3	F4
45	F1	F1	F1	F1	F3	F4
50	F1	F1	F1	F1	F3	F4
60	F1	F1	F1	F1	F3	F4
70	F1	F1	F1	F1	F3	F4
80	F1	F1	F1	F1	F3	F4
90	F2	F2	F2	F2	F3	F4
110	F2	F2	F2	F2	F3	F4
120	F2	F2	F2	F2	F3	F4
130	F2	F2	F2	F2	F3	F4
152	F2	F2	F2	F2	F3	F4
162	F2	F2	F2	F2	F3	F4
190	F4	F4	F5	F5	F5	F5
210	F4	F4	F5	F5	F5	F5
240	F4	F4	F5	F5	F5	F5
260	F4	F4	F5	F5	F5	F5
300	F4	F4	F5	F5	F5	F5
320	F4	F4	F5	F5	F5	F5

\* Please contact sales office

### LEGEND

<b>P2</b>	2 pipe system	<b>P4</b>	4 pipe system with Free Cooling
<b>P4</b>	4 pipe system	<b>P2+A</b>	2 pipe system with hydraulic kit
<b>P2+FC</b>	2 pipe system with Free Cooling	<b>P4+A</b>	4 pipe system with hydraulic kit

# ACCESSORIES

WHA		039÷080	090÷110	120÷162	190÷260	300÷320
Main switch		●	●	●	●	●
Microprocessor control		●	●	●	●	●
Remote ON/OFF digital input		●	●	●	●	●
Summer/Winter digital input		●	●	●	●	●
LS low noise version [-4dB(A) of STD]	LS00	○	○	○	○	○
Electronic Soft starter	DSSE	○	○	○	○	○
Rubber anti-vibration mountings	KAVG	○	○	○	○	○
Spring anti-vibration mountings	KAVM	○	○	○	○	○
Refrigerant circuit pressure gauges	MAML	○	○	○	○	○
Liquid line solenoid valve	VSLI	○	○	○	○	○
Remote control panel	PCRL	○	○	○	○	○
Serial interface card RS485 with MODBUS protocol	INSE *	○	○	○	○	○
2 way modulating to control source water consumption	V2M0	○	○	○	○	○
Electronic thermostatic valve	VTEE	○	○	○	○	○
Hydraulic kit with one pump without tank - user circuit	A1NTU	○	○	○	○	○
Hydraulic kit with one pump without tank - source circuit	A1NTS	○	○	○	○	○
Hydraulic kit with one pump without tank - recovery circuit	A1NTR	○	○	○	○	○
Hydraulic kit with two pumps without tank - user circuit	A2NTU	○	○	○	○	○
Hydraulic kit with two pumps without tank - source circuit	A2NTS	○	○	○	○	○
Hydraulic kit with two pumps without tank - recovery circuit	A2NTR	○	○	○	○	○

● Standard, ○ Optional, – Not available.  
\* Standard for SW6 versions

## OPERATION LIMITS

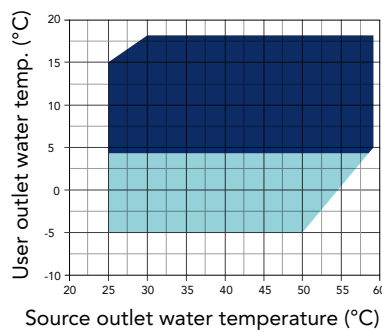
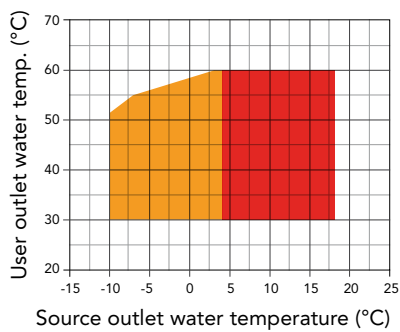

- Heating
  - Heating with glycol source circuit
  - Cooling
  - Cooling with glycol user circuit
- Operating limits with 5°C Δt

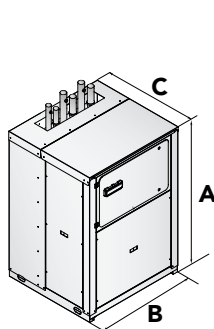

Frame 1

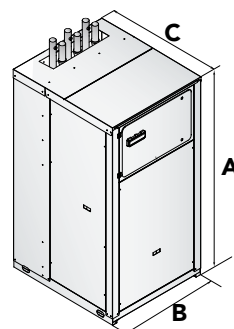

Frame 2

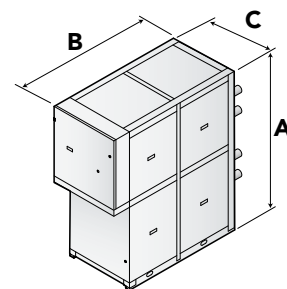

Frame 3

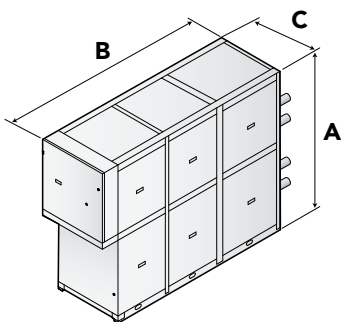

Frame 4

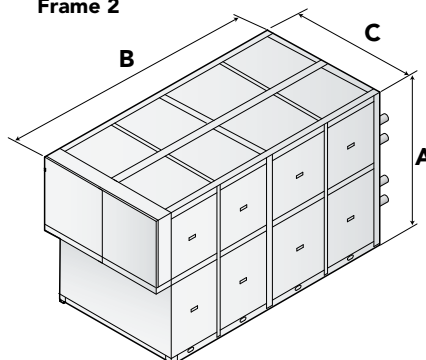

Frame 5

Mod.	A (mm)	B (mm)	C (mm)
F1	1566	1101	1005
F2	1986	1101	1255
F3	1900	2170	800
F4	1900	3120	800
F5	1730	3030	1600

# WHK

## SUPER-HIGH TEMPERATURE WATER TO WATER HEAT PUMPS EQUIPPED WITH SCROLL COMPRESSOR

Heating capacity from 39 kW to 302 kW

R134a

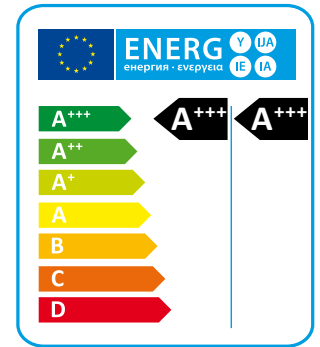

WHK heat pumps are particularly suitable for applications that use source energy at medium or high temperatures. These units have been designed to produce water at high or very high temperature for applications where it is necessary to have maximum efficiency in heating. The units are available in heating only mode and can produce water up to 78°C (HT version). A wide range of accessories allows you to choose the optimal solution.

### VERSIONS

- HH** Standard, heating only.
- LT** Low source/user temperature.
- HT** High source/user temperature.
- LS** Low noise.
- XL** Super low noise.
- P2U** 2 pipe systems without domestic hot water production.

## TECHNICAL DATA

WHK LT/XL/HH - P2U		312	412	612	712	912	1212	1412	1804	2304	2604
Heating capacity (EN14511) <sup>(1)</sup>	kW	38,8	46,0	58,4	70,3	88,4	109,9	136,5	176,9	219,5	273,2
Input power (EN14511) <sup>(1)</sup>	kW	8,2	9,4	11,8	14,8	18,8	23,1	27,9	37,2	45,7	55,3
COP (EN14511) <sup>(1)</sup>	W/W	4,73	4,85	4,93	4,76	4,70	4,75	4,88	4,75	4,80	4,94
Energy Class in low temperature <sup>(2)</sup>		A+++	A+++	A+++	A+++	A+++	A+++	A+++	A+++	A+++	A+++
SCOP low temperature <sup>(2)</sup>	kWh/kWh	4,85	5,00	5,16	5,00	5,08	5,17	5,36	5,29	5,38	5,56
η <sub>s,h</sub> low temperature <sup>(2)</sup>	%	185,9	192,1	198,2	191,8	195,3	198,9	206,3	203,4	207,0	214,4
Energy Class in medium temperature <sup>(2)</sup>		A++	A++	A++	A++	A++	A++	A++	A++	A++	A++
SCOP medium temperature <sup>(2)</sup>	kWh/kWh	4,07	4,19	4,28	4,18	4,16	4,22	4,35	4,27	4,34	4,47
η <sub>s,h</sub> medium temperature <sup>(2)</sup>	%	154,8	159,6	163,0	159,0	158,3	160,9	165,9	162,8	165,6	170,7
Power supply	V/Ph/Hz	400/3/50									
Maximum input current	A	128,7	137,6	168,0	209,0	266,0	324,0	372,5	348,0	428,0	497,5
Peak current	A	35,4	39,2	56,0	70,0	82,0	104,0	125,0	164,0	208,0	250,0
Compressors / Circuits	n°/n°	2/1	2/1	2/1	2/1	2/1	2/1	2/1	4/2	4/2	4/2
Capacity steps	n°	2	2	2	2	2	2	2	4	4	4
Refrigerant		R134a	R134a	R134a	R134a	R134a	R134a	R134a	R134a	R134a	R134a
Global warming potential (GWP)		1430	1430	1430	1430	1430	1430	1430	1430	1430	1430
Refrigerant charge	kg	2,0	2,0	3,0	3,0	4,0	5,0	6,0	8,5	10,5	13,0
Equivalent CO <sub>2</sub> charge	t	2,9	2,9	4,3	4,3	5,7	7,2	8,6	12,2	15,0	18,6
Sound power LS version <sup>(3)</sup>	dB(A)	--	--	--	--	--	--	--	88	89	91
Sound pressure LS version <sup>(4)</sup>	dB(A)	--	--	--	--	--	--	--	72	73	75
Sound power XL version <sup>(3)</sup>	dB(A)	65	65	70	73	74	76	78	--	--	--
Sound pressure XL version <sup>(4)</sup>	dB(A)	49	49	54	57	58	60	62	--	--	--

WHK HT/XL/HH - P2U		161	211	312	412	612	712	912	1212	1412	1804	2304	2604
Heating capacity (EN14511) <sup>(1)</sup>	kW	18,5	21,8	37,6	43,6	64,1	75,1	97,8	121,7	150,5	195,6	243,9	301,2
Input power (EN14511) <sup>(1)</sup>	kW	3,4	3,7	6,7	7,5	11,1	13,7	17,6	21,7	26,2	35,0	43,1	52,2
COP (EN14511) <sup>(1)</sup>	W/W	5,64	5,89	5,65	5,83	5,79	5,48	5,56	5,62	5,74	5,59	5,65	5,77
Energy Class in low temperature <sup>(2)</sup>		A+++	A+++	A+++	A+++	A+++	A+++	A+++	A+++	A+++	A+++	A+++	A+++
SCOP low temperature <sup>(2)</sup>	kWh/kWh	5,79	5,9	5,71	5,83	5,91	5,81	5,85	5,94	6,09	5,95	6,01	6,20
η <sub>s,h</sub> low temperature <sup>(2)</sup>	%	223,7	229,2	220,2	225,3	228,2	224,5	226,0	229,4	235,6	230,0	232,4	239,9
Energy Class in medium temperature <sup>(2)</sup>		A+++	A+++	A++	A++	A++	A++	A++	A++	A++	A++	A++	A++
SCOP medium temperature <sup>(2)</sup>	kWh/kWh	4,4	4,53	4,62	4,73	4,78	4,76	4,67	4,74	4,85	4,73	4,79	4,91
η <sub>s,h</sub> medium temperature <sup>(2)</sup>	%	168,1	173,5	176,9	182,1	183,2	182,2	178,7	181,5	186,1	181,0	183,6	188,3
Power supply	V/Ph/Hz	400/3/50											
Maximum input current	A	95	111	111,4	128,7	167,1	208,3	267,9	324,8	372,9	353,7	430,4	498,7
Peak current	A	16,4	17,7	32,8	35,4	54,2	68,6	85,8	105,6	125,8	171,6	211,2	251,6
Compressors / Circuits	n°/n°	1/1	1/1	2/1	2/1	2/1	2/1	2/1	2/1	2/1	4/2	4/2	4/2
Capacity steps	n°	1	1	2	2	2	2	2	2	2	4	4	4
Refrigerant		R134a	R134a	R134a	R134a	R134a	R134a	R134a	R134a	R134a	R134a	R134a	R134a
Global warming potential (GWP)		1430	1430	1430	1430	1430	1430	1430	1430	1430	1430	1430	1430
Refrigerant charge	kg	3	3	4,0	4,0	5,0	6,0	8,0	10,0	10,0	21,0	26,0	33,0
Equivalent CO <sub>2</sub> charge	t	4,3	4,3	5,7	5,7	7,2	8,6	11,4	14,3	14,3	30,0	37,2	47,2
Sound power LS version <sup>(3)</sup>	dB(A)	--	--	--	--	--	--	--	--	--	88	89	91
Sound pressure LS version <sup>(4)</sup>	dB(A)	--	--	--	--	--	--	--	--	--	72	73	75
Sound power XL version <sup>(3)</sup>	dB(A)	62	62	65	65	70	73	74	76	78	--	--	--
Sound pressure XL version <sup>(4)</sup>	dB(A)	46	46	49	49	54	57	58	60	62	--	--	--

Performances are referred to the following conditions:

(1) Heating: user water temperature 30/35°C, source water temperature 10/7°C.

(2) Average conditions, variable - Reg EU 811/2013

(3) Sound power level in accordance with ISO 3744.

(4) Sound pressure level at 1 mt from the unit in free field conditions in accordance with ISO 3744.

## COMPONENTS

### FRAME

All units are made from hot-galvanised sheet steel, painted with polyurethane powder enamel and stoved at 180°C to provide maximum protection against corrosion. The frame is self-supporting with removable panels. All screws and rivets used are made from stainless steel. The standard colour of the units is RAL 9018.

### REFRIGERANT CIRCUIT

The refrigerant utilised is R134a. The refrigerant circuit is assembled using internationally recognised brand name components with all brazing and welding being performed in accordance with ISO 97/23. Each refrigerant circuit is totally independent from the other with the result that any fault or alarm condition on one circuit does not influence the other. The refrigerant circuit includes: sight glass, filter drier, thermal expansion valve with external equalizer, Schrader valves for maintenance and control and pressure safety device (for compliance with PED regulations).

### COMPRESSORS

The compressors used are a high performance scroll type that incorporates a special scroll design which enhances the efficiency of the refrigerant cycle when the source temperature is low. The compressors are all supplied with a crankcase heater and thermal overload protection by a klixon embedded in the motor winding. They are mounted in a separate enclosure thus enabling them to be maintained even if the unit is operating. Access to this enclosure is via the front panel of the unit. The crankcase heater is always powered when the compressor is in stand-by.

### SOURCE HEAT EXCHANGER

Source heat exchanger are braze-welded plates and are made of stainless steel AISI 316.

The use of this type of exchangers greatly reduces the refrigerant charge of the unit compared to the conventional shell and tube evaporators, and increases the efficiency of the refrigerant loads. The heat exchangers are factory insulated with flexible close cell material and are protected by a temperature sensor used as antifreeze protection kit.

### USER EXCHANGER

The user side heat exchanger is a braze welded, plate type heat exchanger, manufactured from AISI 316 stainless steel. All units are supplied with a sub-cooler to enhance the performance of the refrigerant cycle. The user heat exchangers are factory insulated with flexible close cell material.

### MICROPROCESSORS

All units are supplied as standard with microprocessor controls. The microprocessor controls the following functions: control of the water temperature, antifreeze protection, compressor timing, compressor automatic starting sequence, alarm reset, volt free contact for remote general alarm, alarms and operation LED's. If required (available as an option), the microprocessor can be configured in order for it to connect to a site BMS system thus enabling remote control and management. The technical department can discuss and evaluate, in conjunction with the customer, solutions using MODBUS protocols.

### ELECTRIC ENCLOSURE

The enclosure is manufactured in order to comply with the requirements of the electromagnetic compatibility standards CEE EN60204. Access to the enclosure is achieved by removing the front panel of the unit. The following components are supplied as standard on all units: main switch, thermal overloads (protection of pumps and fans), compressor fuses, control circuit automatic breakers, compressor contactors, fan

contactors and pump contactors. The terminal board has volt free contacts for remote ON-OFF, Summer/Winter change over (reversible type only) and general alarm. For all three phase units, a sequence relay that disables the power supply in the event that the phase sequence is incorrect (scroll compressors can be damaged if they rotate in the wrong direction), is fitted as standard.

### CONTROL AND PROTECTION DEVICES

All units are supplied with the following control and protection devices: Return and supply user heat exchanger sensors, return and supply source heat exchanger sensors, high pressure switch with manual reset, low pressure switch with automatic reset, high pressure safety valve, compressor thermal overload protection, pump thermal overload protection (when present), source heat exchanger flow switch.

## VERSIONS

### WHK/HH

These units have been designed to produce water at high or very high temperature by using a source water temperature of 12°C with possibility to produce hot water up to 70°C or more.

### WHK/HH/HT

This version is equipped with special compressors that allow the cooling circuit to manage high source water temperature, up to 45°C, with the consequent possibility of producing very high water temperatures on the user side up to 78°C.

### WHK/HH/LT

This version is equipped with special compressors that allow the cooling circuit to manage medium source water temperature, up to 20°C, with the consequent possibility of producing very high water temperatures on the user side up to 70°C.

### Version LS

This version includes the complete acoustic insulation of the unit with compressor jackets and insulating material made with high density media and the interposition of heavy bitumen layer.

### Super low noise version XL

All units in XL versions are supplied, as standard, with the latest 'Floating Frame' technology that completely isolates the compressors from the main casing, thereby eliminating vibration and noise from this source. The 'Floating Frame' is a special vibration and acoustic damping system that consists of a base plate and acoustic enclosure that houses the compressors. The base plate is separated from the supporting frame of the unit by soft steel springs that have a high damping power. Within the enclosure, the compressors are mounted on rubber shock absorbers on the floating base plate. The enclosure is manufactured from galvanized steel sandwich panels that have a micro-perforated inner skin and a core of 30 mm thick, high density (25 kg/m<sup>3</sup>). The entire arrangement provides a double damping system and acoustic attenuation. The compressor refrigerant pipes are connected to the refrigerant circuit through "anaconda" flexible connections. Flexible connections are also used on the water pipework within the unit. The combination of these systems results in an overall noise reduction in the region of 6-8 dB(A).

# ACCESSORIES

WHK		161	211	312	412	612	712	912	1212	1412	1804	2304	2604
XL Super low noise version	<b>XL00</b>	●	●	●	●	●	●	●	●	●	-	-	-
LS low noise version [-4dB(A) of STD]	<b>LS00</b>	-	-	-	-	-	-	-	-	-	●	●	●
Electronic Soft starter	<b>DSSE</b>	○	○	○	○	○	○	○	○	○	○	○	○
Rubber anti-vibration mountings	<b>KAVG</b>	○	○	○	○	○	○	○	○	○	○	○	○
Spring anti-vibration mountings	<b>KAVM</b>	○	○	○	○	○	○	○	○	○	○	○	○
Refrigerant circuit pressure gauges	<b>MAML</b>	○	○	○	○	○	○	○	○	○	○	○	○
Liquid line solenoid valve	<b>VSLI</b>	-	-	-	-	-	-	-	-	-	-	-	-
Remote control panel	<b>PCRL</b>	○	○	○	○	○	○	○	○	○	○	○	○
Serial interface card RS485	<b>INSE</b>	●	●	●	●	●	●	●	●	●	●	●	●
2 way modulating valve - source	<b>V2M0</b>	○	○	○	○	○	○	○	○	○	○	○	○
Electronic thermostatic valve	<b>VTEE</b>	●	●	●	●	●	●	●	●	●	●	●	●

● Standard, ○ Optional, - Not available.

## OPERATION LIMITS

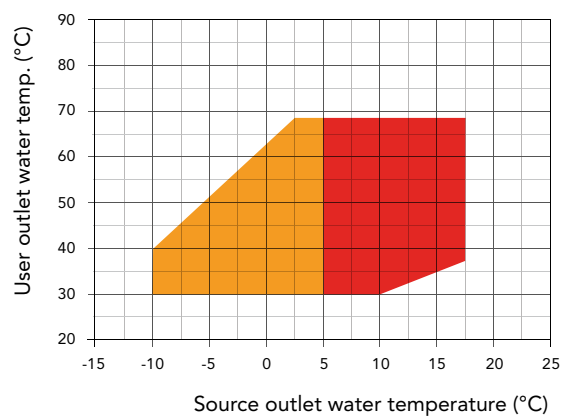
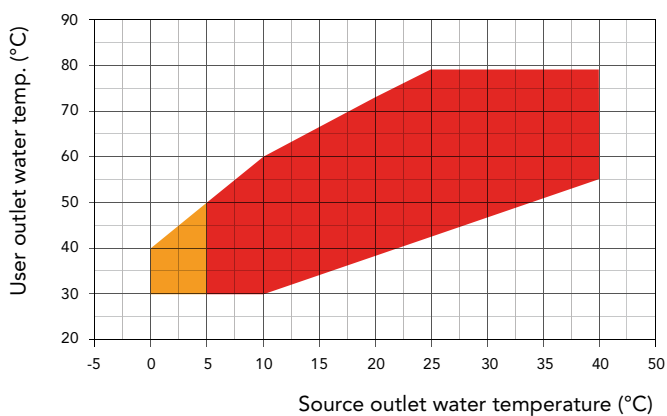

■ Standard version  
■ Standard version with glycol

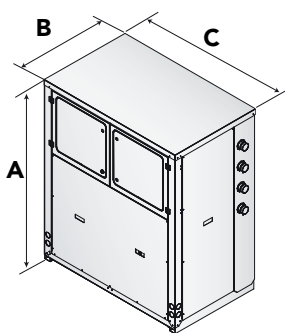

Mod.	A (mm)	B (mm)	C (mm)	kg
161	1631	790	1145	410
211	1631	790	1145	410
312	1631	790	1145	510
412	1656	790	1145	730
612	1656	790	1145	750
712	1656	790	1145	780
912	1656	790	1145	790
1212	1656	790	1145	810
1412 (LT)	1656	790	1145	840

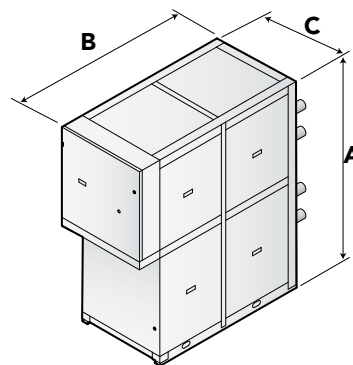

Mod.	A (mm)	B (mm)	C (mm)	kg
1412 (HT)	1900	2177	794	1450
1804	1900	3127	794	1320
2304	1900	3127	794	1390
2604	1900	3127	794	1430

# LHi/P4

## HIGH EFFICIENCY AIR TO WATER MULTIPURPOSE UNIT AND 4 PIPE HEAT PUMPS EQUIPPED WITH INVERTER COMPRESSOR AND AXIAL FANS

Heating capacity from 54 kW to 271 kW

R410A

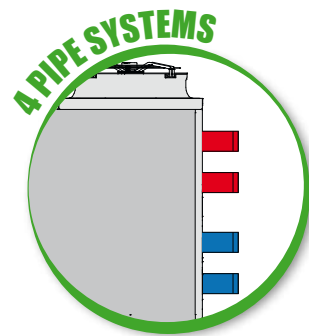
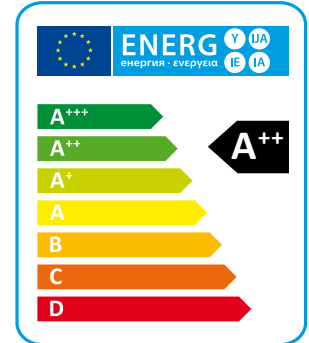

The LHi P4U/P4S series high-efficiency air-to-water heat pumps are units designed for four-pipe air conditioning and heating systems, which allow the simultaneous or separate production of cold water for cooling and hot water for heating. The units are supplied with an additional exchanger, used as a condenser for hot water, whose production is independent of the unit's operating mode. The exchanger is automatically activated by microprocessor control when the hot water temperature on the return flow is lower than the set applied. These units are able to produce hot water and cold water simultaneously and/or separately with very high energy efficiency.

They are all supplied complete with a specific advanced microprocessor control equipped with software for the management of the various priorities.

The XL versions also have an extremely low noise level thanks to the use of a special floating vibration dampening system that allows a noise reduction of about 6-8 dB(A) (optional).

### VERSIONS

- RV** Reversible heating/cooling.
- SE** Standard efficiency, EC fans.
- LS** Low noise.
- XL** Super low noise.
- P4U** 4 pipe systems heating/cooling.
- P4S** 2+2 pipe systems with D.H.W. production.

## TECHNICAL DATA

SE/LS/RV - P4S		532	632	742	862	912	1052	1222	1534	1654	1854	1964	2254	2554
Heating capacity (EN14511) <sup>(1)</sup>	kW	53,3	61,8	74,2	85,1	90,9	102,5	118,3	129,0	145,3	165,2	188,7	223,4	269,6
Total input power (EN14511) <sup>(1)</sup>	kW	13,2	14,7	18,7	20,0	22,1	24,9	28,5	31,2	34,0	39,1	44,8	55,1	65,8
COP (EN14511) <sup>(1)</sup>	W/W	4,04	4,19	3,97	4,25	4,11	4,12	4,15	4,14	4,27	4,23	4,21	4,06	4,10
Energy Class <sup>(2)</sup>		A++	A++	A++	A++	A++	A++	A++	A++	A++	A++	A++	A++	A++
SCOP <sup>(2)</sup>	kWh/kWh	3,88	3,93	3,90	3,98	3,92	3,93	3,88	3,95	3,93	4,00	3,90	3,88	3,88
$\eta_{s,h}$ <sup>(2)</sup>	%	152	154	153	156	154	154	152	155	154	157	153	152	152
Cooling capacity (EN14511) <sup>(3)</sup>	kW	49,32	57,71	68,9	78,87	83,19	95,32	109,3	112,8	129,4	146,3	162,5	197,4	230,6
Total input power (EN14511) <sup>(3)</sup>	kW	16,42	18,47	24,48	25,78	28,18	31,81	36,3	40,3	42,6	50,2	57,0	69,5	84,6
EER (EN14511) <sup>(3)</sup>	W/W	3,00	3,12	2,81	3,06	2,95	3,00	3,01	2,80	3,04	2,91	2,85	2,84	2,72
TER (EN 14511) <sup>(4)</sup>		10,00	10,27	9,72	10,12	9,84	9,98	10,08	10,32	10,45	10,43	9,99	9,94	9,78
Sound power level <sup>(5)</sup>	dB (A)	81	81	83	83	83	84	85	86	87	87	87	89	89
Sound pressure level <sup>(6)</sup>	dB (A)	49	49	51	51	51	52	53	54	55	55	55	57	57
Power supply	V/Ph/Hz	400/3/50	400/3/50	400/3/50	400/3/50	400/3/50	400/3/50	400/3/50	400/3/50	400/3/50	400/3/50	400/3/50	400/3/50	400/3/50
Compressors / Circuits	n° / n°	2 / 1	2 / 1	2 / 1	2 / 1	2 / 1	2 / 1	2 / 1	4 / 2	4 / 2	4 / 2	4 / 2	4 / 2	4 / 2
Fans	n°	2	2	2	3	3	3	4	2	3	3	3	4	4
Refrigerant		R410A	R410A	R410A	R410A	R410A	R410A	R410A	R410A	R410A	R410A	R410A	R410A	R410A
Refrigerant charge	kg	10,4	14,7	14,7	17,5	17,5	22,3	22,7	32,6	39,8	39,8	45,5	50,9	59,0
Global warming potential (GWP)		2088	2088	2088	2088	2088	2088	2088	2088	2088	2088	2088	2088	2088
Equivalent CO <sub>2</sub> charge	t	21,8	30,7	30,7	36,5	36,5	46,5	47,4	68,0	83,2	83,2	95,0	106,2	123,1
Water tank volume	l	140	300	300	500	500	500	500	300	500	500	500	500	500

SE/LS/RV - P4U		532	632	742	862	912	1052	1222	1534	1654	1854	1964	2254	2554
Heating capacity (EN14511) <sup>(1)</sup>	kW	53,2	61,8	74,5	86,4	90,9	102,4	118,3	129,5	146,2	166,9	189,9	224,4	270,6
Total input power (EN14511) <sup>(1)</sup>	kW	12,8	14,3	18,2	19,8	21,5	24,3	27,9	30,3	33,0	38,1	43,4	53,4	63,4
COP (EN14511) <sup>(1)</sup>	W/W	4,17	4,31	4,09	4,36	4,22	4,22	4,24	4,28	4,43	4,38	4,38	4,20	4,27
Energy Class <sup>(2)</sup>		A++	A++	A++	A++	A++	A++	A++	A++	A++	A++	A++	A++	A++
SCOP <sup>(2)</sup>	kWh/kWh	3,93	3,98	4,00	4,05	3,98	3,95	3,85	4,05	4,00	4,05	3,98	3,93	3,90
$\eta_{s,h}$ <sup>(2)</sup>	%	154	156	157	159	156	155	151	159	157	159	156	154	153
Cooling capacity (EN14511) <sup>(3)</sup>	kW	56,6	66,0	81,1	91,0	96,5	110,9	126,9	133,0	147,2	171,7	188,5	228,7	271,8
Total input power (EN14511) <sup>(3)</sup>	kW	12,6	14,2	18,6	19,9	21,8	24,7	27,9	28,5	31,2	36,4	41,9	51,1	61,9
EER (EN14511) <sup>(3)</sup>	W/W	4,51	4,64	4,37	4,57	4,43	4,50	4,55	4,66	4,73	4,72	4,50	4,47	4,39
TER (EN 14511) <sup>(4)</sup>		10,00	10,27	9,72	10,12	9,84	9,98	10,08	10,32	10,45	10,43	9,99	9,94	9,78
Sound power level <sup>(5)</sup>	dB (A)	81	81	83	83	83	84	85	86	87	87	87	89	89
Sound pressure level <sup>(6)</sup>	dB (A)	49	49	51	51	51	52	53	54	55	55	55	57	57
Power supply	V/Ph/Hz	400/3/50	400/3/50	400/3/50	400/3/50	400/3/50	400/3/50	400/3/50	400/3/50	400/3/50	400/3/50	400/3/50	400/3/50	400/3/50
Compressors / Circuits	n° / n°	2 / 1	2 / 1	2 / 1	2 / 1	2 / 1	2 / 1	2 / 1	4 / 2	4 / 2	4 / 2	4 / 2	4 / 2	4 / 2
Fans	n°	2	2	2	3	3	3	4	2	3	3	3	4	4
Refrigerant		R410A	R410A	R410A	R410A	R410A	R410A	R410A	R410A	R410A	R410A	R410A	R410A	R410A
Refrigerant charge	kg	10,4	14,7	14,7	17,5	17,5	22,3	22,7	32,6	39,8	39,8	45,5	50,9	59,0
Global warming potential (GWP)		2088	2088	2088	2088	2088	2088	2088	2088	2088	2088	2088	2088	2088
Equivalent CO <sub>2</sub> charge	t	21,8	30,7	30,7	36,5	36,5	46,5	47,4	68,0	83,2	83,2	95,0	106,2	123,1
Water tank volume	l	140	300	300	500	500	500	500	300	500	500	500	500	500

Performances are referred to the following conditions:

- (1) Heating: Ambient temperature 7°C DB, 6°C WB, water temperature 30/35°C.
- (2) Average conditions, low temperature, variable - Reg EU 811/2013.
- (3) Cooling: ambient air temperature 35°C, evaporator water temperature in/out 12/7 °C.

(4) TER: Total Energy Ratio-cold circuit 12/7°C, hot circuit 30/35°C

(5) Sound power level in accordance with ISO 3744.

(6) Sound pressure level at 10 mt from the unit in free field conditions in accordance with ISO 3744.

SE/XL/RV - P4S		532	632	742	862	912	1052	1222	1534	1654	1854	1964	2254	2554
Heating capacity (EN14511) <sup>(1)</sup>	kW	51,8	59,4	77,1	82,9	87,8	101,9	114,4	126,9	142,2	163,6	184,6	224,7	267,2
Total input power (EN14511) <sup>(1)</sup>	kW	12,8	14,3	18,6	19,8	21,5	24,2	27,7	30,1	32,3	37,7	42,9	53,3	63,8
COP (EN14511) <sup>(1)</sup>	W/W	4,04	4,15	4,15	4,20	4,08	4,21	4,13	4,22	4,41	4,35	4,31	4,22	4,19
Energy Class <sup>(2)</sup>		A++	A++	A++	A++	A++	A++	A++	A++	A++	A++	A++	A++	A++
SCOP <sup>(2)</sup>	kWh/kWh	3,95	4,10	4,08	4,13	4,10	4,03	4,00	4,18	4,28	4,25	4,18	4,15	4,13
$\eta_{s,h}$ <sup>(2)</sup>	%	155	161	160	162	161	158	157	164	168	167	164	163	162
Cooling capacity (EN14511) <sup>(3)</sup>	kW	48,0	55,9	70,4	76,4	80,4	91,9	105,7	109,4	124,9	140,1	154,6	198,5	231,8
Total input power (EN14511) <sup>(3)</sup>	kW	16,3	18,4	22,7	25,6	28,1	32,1	36,2	38,9	40,8	49,4	56,0	62,9	77,9
EER (EN14511) <sup>(3)</sup>	W/W	2,86	2,96	3,00	2,90	2,79	2,80	2,84	2,68	2,93	2,73	2,67	2,97	2,83
TER (EN 14511) <sup>(4)</sup>		10,00	10,27	9,72	10,12	9,84	9,98	10,08	10,32	10,45	10,43	9,99	9,94	9,78
Sound power level <sup>(5)</sup>	dB (A)	76	77	78	78	79	79	80	80	80	80	82	83	84
Sound pressure level <sup>(6)</sup>	dB (A)	44	45	46	46	47	47	48	48	48	48	50	51	52
Power supply	V/Ph/Hz	400/3/50	400/3/50	400/3/50	400/3/50	400/3/50	400/3/50	400/3/50	400/3/50	400/3/50	400/3/50	400/3/50	400/3/50	400/3/50
Compressors / Circuits	n° / n°	2 / 1	2 / 1	2 / 1	2 / 1	2 / 1	2 / 1	2 / 1	4 / 2	4 / 2	4 / 2	4 / 2	4 / 2	4 / 2
Fans	n°	2	2	2	3	3	3	4	2	3	3	3	4	4
Refrigerant		R410A	R410A	R410A	R410A	R410A	R410A	R410A	R410A	R410A	R410A	R410A	R410A	R410A
Refrigerant charge	kg	10,4	14,7	16,3	17,5	17,5	22,3	22,7	32,6	39,8	39,8	32,5	50,9	59,0
Global warming potential (GWP)		2088	2088	2088	2088	2088	2088	2088	2088	2088	2088	2088	2088	2088
Equivalent CO <sub>2</sub> charge	t	21,8	30,7	34,1	36,5	36,5	46,5	47,4	68,0	83,2	83,2	67,8	106,2	123,1
Water tank volume	l	140	300	300	500	500	500	500	300	500	500	500	500	500

SE/XL/RV - P4U		532	632	742	862	912	1052	1222	1534	1654	1854	1964	2254	2554
Heating capacity (EN14511) <sup>(1)</sup>	kW	51,2	59,3	77,1	82,8	87,5	97,8	114,0	127,3	143,9	162,5	184,9	217,3	264,7
Total input power (EN14511) <sup>(1)</sup>	kW	12,4	13,9	18,0	19,3	20,9	23,6	27,1	29,2	31,6	36,4	41,5	50,6	61,8
COP (EN14511) <sup>(1)</sup>	W/W	4,14	4,25	4,29	4,30	4,18	4,14	4,21	4,36	4,56	4,46	4,46	4,29	4,29
Energy Class <sup>(2)</sup>		A++	A++	A++	A++	A++	A++	A++	A++	A++	A++	A++	A++	A++
SCOP <sup>(2)</sup>	kWh/kWh	3,98	4,15	4,15	4,18	4,13	4,08	4,03	4,28	4,38	4,38	4,33	4,20	4,15
$\eta_{s,h}$ <sup>(2)</sup>	%	156	163	163	164	162	160	158	168	172	172	170	165	163
Cooling capacity (EN14511) <sup>(3)</sup>	kW	48,0	55,9	70,4	76,4	80,4	91,9	105,7	109,4	124,9	140,1	154,6	198,5	231,8
Total input power (EN14511) <sup>(3)</sup>	kW	16,3	18,4	22,7	25,6	28,1	32,1	36,2	38,9	40,8	49,4	56,0	62,9	77,9
EER (EN14511) <sup>(3)</sup>	W/W	2,86	2,96	3,00	2,90	2,79	2,80	2,84	2,68	2,93	2,73	2,67	2,97	2,83
TER (EN 14511) <sup>(4)</sup>		10,00	10,27	9,72	10,12	9,84	9,98	10,08	10,32	10,45	10,43	9,99	9,94	9,78
Sound power level <sup>(5)</sup>	dB (A)	76	77	78	78	79	79	80	80	80	80	82	83	84
Sound pressure level <sup>(6)</sup>	dB (A)	44	45	46	46	47	47	48	48	48	48	50	51	52
Power supply	V/Ph/Hz	400/3/50	400/3/50	400/3/50	400/3/50	400/3/50	400/3/50	400/3/50	400/3/50	400/3/50	400/3/50	400/3/50	400/3/50	400/3/50
Compressors / Circuits	n° / n°	2 / 1	2 / 1	2 / 1	2 / 1	2 / 1	2 / 1	2 / 1	4 / 2	4 / 2	4 / 2	4 / 2	4 / 2	4 / 2
Fans	n°	2	2	2	3	3	3	4	2	3	3	3	4	4
Refrigerant		R410A	R410A	R410A	R410A	R410A	R410A	R410A	R410A	R410A	R410A	R410A	R410A	R410A
Refrigerant charge	kg	10,4	14,7	16,3	17,5	17,5	22,3	22,7	32,6	39,8	39,8	32,5	50,9	59,0
Global warming potential (GWP)		2088	2088	2088	2088	2088	2088	2088	2088	2088	2088	2088	2088	2088
Equivalent CO <sub>2</sub> charge	t	21,8	30,7	34,1	36,5	36,5	46,5	47,4	68,0	83,2	83,2	67,8	106,2	123,1
Water tank volume	l	140	300	300	500	500	500	500	300	500	500	500	500	500

Performances are referred to the following conditions:

- (1) Heating: Ambient temperature 7°C DB, 6°C WB, water temperature 30/35°C.  
(2) Average conditions, low temperature, variable - Reg EU 811/2013.  
(3) Cooling: ambient air temperature 35°C, evaporator water temperature in/out 12/7 °C.

- (4)TER: Total Energy Ratio-cold circuit 12/7°C, hot circuit 30/35°C  
(5) Sound power level in accordance with ISO 3744.  
(6) Sound pressure level at 10 mt from the unit in free field conditions in accordance with ISO 3744.

## COMPONENTS

### FRAME

All units are made from hot-galvanised sheet steel, painted with polyurethane powder enamel and stoved at 180°C to provide maximum protection against corrosion. The frame is self-supporting with removable panels. All screws and rivets used are made from stainless steel. The standard colour of the units is RAL9018.

### REFRIGERANT CIRCUIT

The refrigerant utilised is R410A. The refrigerant circuit is assembled using internationally recognised brand name components with all brazing and welding being performed in accordance with ISO 97/23. The refrigerant circuit includes: sight glass, filter drier, two thermal expansion valves (one for cooling mode, one for heating mode) with external equalizer, 4 way reversing valve, check valves, liquid receiver, Schrader valves for maintenance and control, pressure safety device (for compliance with PED regulations).

### COMPRESSORS

The compressors used are three-phase scroll type BPM (brushless permanent magnet) high efficiency, controlled by an Inverter, supplied with a specific design that increases the efficiency of the refrigerant cycle in very low ambient temperature conditions. All sizes use compressors in tandem configuration, and are all optimized for heat pump applications for high seasonal efficiency (SCOP).

The compressors are all supplied with electrical resistance and thermal overload protection. They are all mounted in a dedicated compartment to keep them separated from the airflow. The electric heater is always powered when the compressor is in stand by mode. Maintenance is possible through the front panel of the unit which allows to reach the compressors even when the machine is running.

### SOURCE HEAT EXCHANGER

The source heat exchanger is made from copper pipes and aluminium fins. Dimensioning of the copper pipes and the aluminium wings is optimized in order to obtain excellent performance.

The tubes are mechanically expanded into the fins in order to maximise heat transfer. Furthermore, the design guarantees a low air side pressure drop thus enabling the use of low rotation speed (and hence low noise) fans. All heat exchangers are supplied standard with fins hydrophilic coating.

### USER HEAT EXCHANGERS (P4U/P4S versions)

The user heat exchanger is a braze welded, plate type heat exchanger, manufactured from AISI 316 stainless steel. The use of this type of exchanger results in a massive reduction of the refrigerant charge of the unit compared to a traditional shell-in-tube type. A further advantage is a reduction in the overall dimensions of the unit.

The exchangers are factory insulated with flexible close cell material and can be fitted with an antifreeze heater (accessory). Each exchanger is fitted with a temperature sensor on the discharge water side for antifreeze protection.

### HIGH EFFICIENCY E.C. AXIAL FANS (VECE)

High efficiency E.C. axial fans, supplied with Brushless DC electric motors electronically commutated (E.C. motors) able to grants the highest energy efficiency class according to the latest EU specifications, with the result of substantial energy consumption reduction for ventilation. The fans are statically and dynamically balanced and supplied complete with a safety fan guard complying with the requirements of EN 60335. The fans are installed using a special steel profiled beam who minimize all vibrations. All units are fitted with a pressure transducer for the control of the evaporation/condensation pressure. All electric motors are The motors are fitted with integrated thermal overload protection rating IP54.

### MICROPROCESSORS

All units are supplied as standard complete with control panel. The microprocessor controls the following functions: control of the water temperature, antifreeze protection, compressor timing, compressor automatic starting sequence (For multiple compressors), alarm reset.

The control panel is supplied with display showing all operational icons. The microprocessor is set for automatic defrost (when operating in severe ambient conditions) and for summer/ winter change over (only for RV versions).

The control also manages the anti-legionella program, the integration with other heating sources (electric heaters, boilers, solar panels etc), the operation of a three port modulating valve (for diverting to DHW or heating) and both the heating circuit pump and the domestic hot water circuit pump. If required (available as an option), the microprocessor can be configured in order for it to connect to a site BMS system thus enabling remote control and management.

### ELECTRIC ENCLOSURE

The enclosure is manufactured in order to comply with the requirements of the electromagnetic compatibility standards CEE EN60204. Access to electrical cabinet in quick and easy thanks to hinged panels. The following components are supplied as standard on all units: main switch, a sequence relay that disables the power supply in the event that the phase sequence is incorrect (scroll compressors can be damaged if they rotate in the wrong direction), thermal overloads (protection of pumps and fans), compressor fuses, control circuit automatic breakers, compressor contactors, fan contactors and pump contactors. The terminal board has volt free contacts for remote ON-OFF, Summer/ winter change over (heat pumps only) and general alarm.

### CONTROL AND PROTECTION DEVICES

All units are supplied with the following controls and protections: user water return temperature sensor, antifreeze protection temperature sensor installed on users water output, domestic hot water supply and return temperature sensors (only versions P2S), high pressure and low pressure automatic reset, compressor thermal protection, air fan, thermal protection, pressure transducer (used to optimize the defrost cycle and to adjust the fan speed depending on ambient conditions), flow switch.

All units are also fitted with a temperature probe sensor with "Energy Saving" function, supplied in a separate plastic box, which can be used to stop the pump use during periods of stand-by, when the water temperature reaches the set point. Doing this the power consumption of the unit is strongly reduced.

#### USER AND RECOVERY FLOW SWITCH (P4U/P4S VERSIONS)

The flow utility is installed as standard on all units and disables the operation of the unit in case of abnormal water flow in the system. The flow switch is made of a blade system fitted in the flow of the water; it is combined with two permanent magnets that assess the amount of water in transit and, in function of the measured parameter, enable or not the operation of the unit.

#### ELECTRONIC EXPANSION VALVE (VTEE)

The use of the electronic thermostatic valve is particularly suitable for units operating under very variable load conditions. The electronic expansion valve enables the maximum possible efficiency to be achieved by maximizing the evaporator heat exchange, minimizing the reaction time to load variations and optimizing the superheat. The use of the electronic thermostatic valve is particularly suitable for units operating under very variable load conditions.

## VERSIONS

#### P4S Version

This is a four pipe version that can produce hot water for heating (HH version), hot and cold water for cooling and domestic hot water (only RV versions) in all operational modes using an independent water circuit. When cooling, DHW generation is by heat recovery. This unit is normally used with two pipe water based change-over systems with the DHW circuit being separate.

#### P4U Version

This is a four pipe version that provides a modern approach to four pipe water based systems. Instead of using a boiler and chiller, this unit can generate hot water in one circuit, cold water in the other circuit either individually or simultaneously. When operating in simultaneous mode the heating capacity is equal to the cooling duty plus the power input to the compressors. The operating efficiency in this mode is extremely high. Domestic hot water production for this version is not available.

#### RV Version

This version uses 2 hydraulic connections and is able to produce hot water in winter and cold water in summer. The unit is combined with a 2-pipe system.

#### SE Version

Standard efficiency version, according to current standard. Unit equipped with EC fans.

#### LS Version

This version includes the complete acoustic insulation of the unit with compressor jackets and insulating material made with high density media and the interposition of heavy bitumen layer.

### P4U VERSION

User water heating

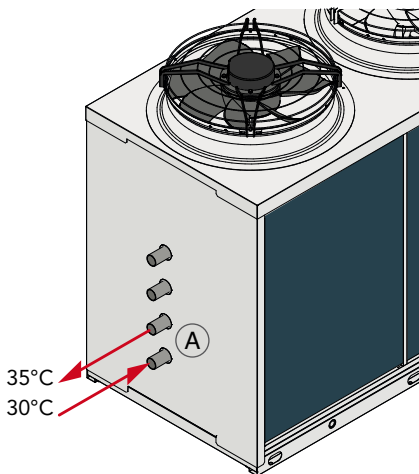

User water cooling

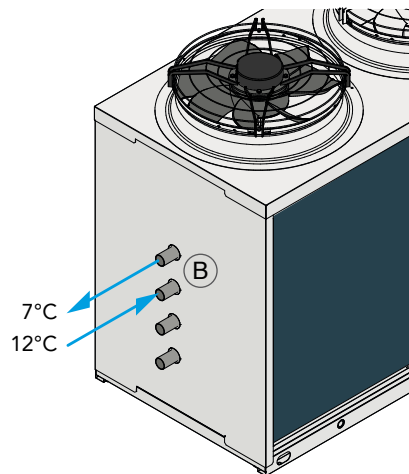

Simultaneous user Cooling + heating

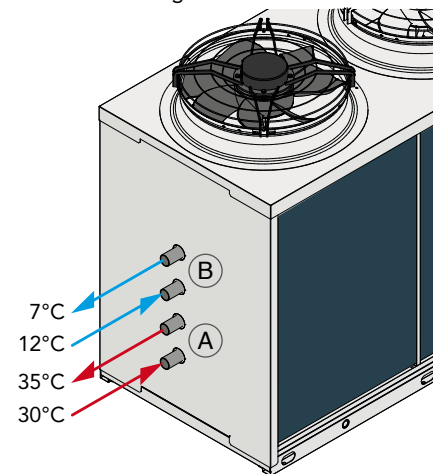

The above scheme is for illustrative purposes only. For the correct pipes placement, please refer to the units technical manual.

**XL Super low noise version**

All units in XL super low noise version are supplied, as standard, with the latest 'Floating Frame' technology that completely isolates the compressors from the main casing, thereby eliminating vibration and noise from this source. The 'Floating Frame' is a special vibration and acoustic damping system that consists of a base plate and acoustic enclosure that houses the compressors. The base plate is separated from the supporting frame of the unit by soft steel springs that have a high damping power. Within the enclosure, the compressors are mounted on rubber shock absorbers on the floating base plate. The enclosure is manufactured from galvanized steel sandwich panels that have a micro-perforated inner skin and a core of 30 mm thick, high density (25 kg/m<sup>3</sup>). The entire arrangement provides a double damping system and acoustic attenuation. The compressor refrigerant pipes are connected to the refrigerant circuit through "anaconda" flexible connections. Flexible connections are also used on the water pipework within the unit. The combination of these systems results in an overall noise reduction in the region of 5-7 dB(A).

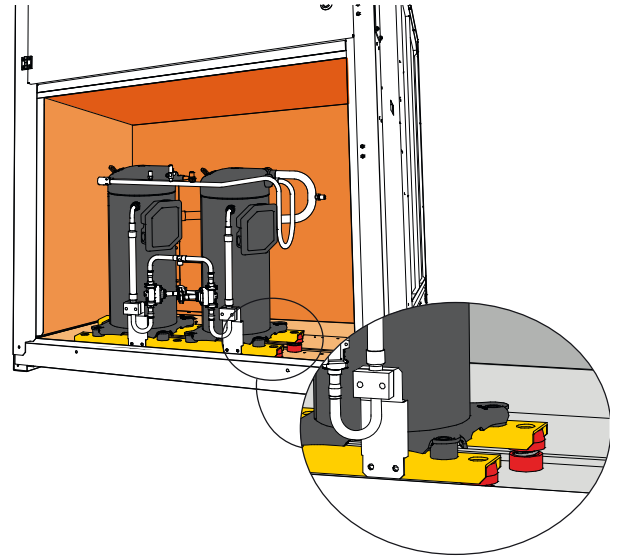

**OPERATION LIMITS**

(SE versions)

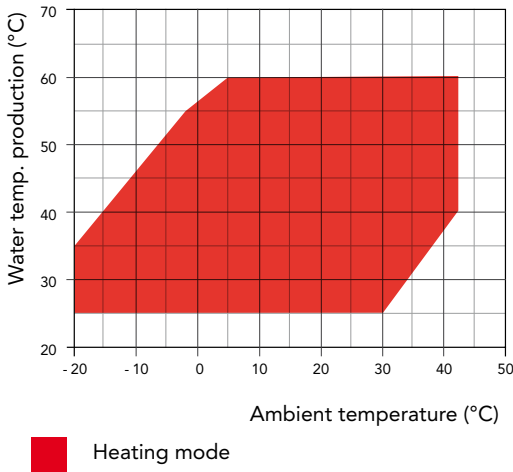

(RV versions Only)

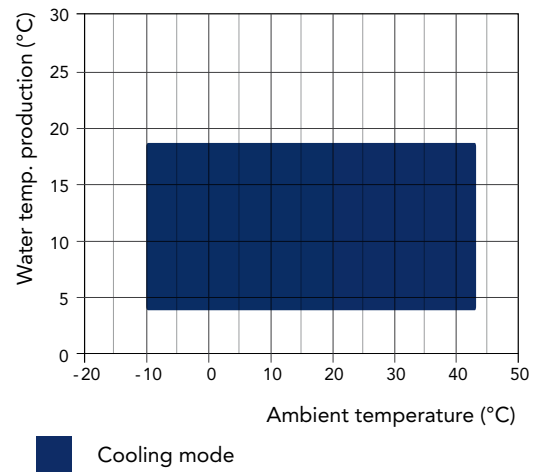

**P4S VERSION**

User water heating

User water cooling

Domestic hot water production (D.H.W.)

User water cooling + D.H.W. production

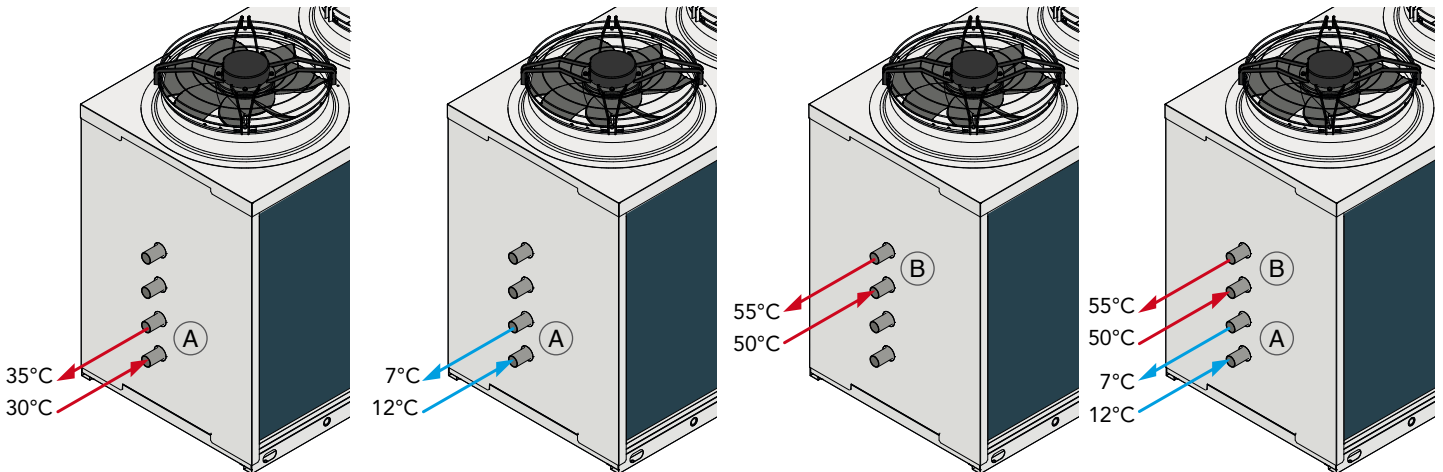

The above scheme is for illustrative purposes only. For the correct pipes placement, please refer to the units technical manual.

# ACCESSORIES

LHi/P4

LHi SE/HH-RV	P4S/P4U	532	632	742	862	912	1052	1222
Flow switch		●	●	●	●	●	●	●
"Floating frame" Technology - XL Version		●	●	●	●	●	●	●
E.C. fans - SE versions	VECE	●	●	●	●	●	●	●
Condensate discharge drip tray with antifreeze heater	BRCA	○	○	○	○	○	○	○
Antifreeze kit for 4 pipe units	RAEV4	○	○	○	○	○	○	○
Electronic soft starter	DSSE	○	○	○	○	○	○	○
Serial interface card RS485	INSE	●	●	●	●	●	●	●
Rubber anti-vibration mountings	KAVG	○	○	○	○	○	○	○
Remote control panel	PCRL	○	○	○	○	○	○	○
Electronic expansion valve	VTEE	●	●	●	●	●	●	●
Power factor correction system	RICO	○	○	○	○	○	○	○
Power factor correction system with soft starter	RICSS	○	○	○	○	○	○	○
Spring vibration dampers	KAVM	○	○	○	○	○	○	○
Coil protection grid	GBPE	○	○	○	○	○	○	○
Shut-off valve on compressor discharging side	RDCO	○	○	○	○	○	○	○
Shut-off valve on compressor suction side	RHCO	○	○	○	○	○	○	○
Hydraulic kit with one inverter pump	A1VSU	○	○	○	○	○	○	○
Hydraulic kit with one pump without tank	A1NTU	○	○	○	○	○	○	○
Hydraulic kit with one higher available pressure pump	A1HPU	○	○	○	○	○	○	○
Hydraulic kit with two pumps without tank	A2NTU	○	○	○	○	○	○	○
Hydraulic kit with tank and one inverter pump	A1VVU	○	○	○	○	○	○	○
Hydraulic kit with one pump with tank	A1ZZU	○	○	○	○	○	○	○
Hydraulic kit with tank and one one higher available pressure pump	A1HHU	○	○	○	○	○	○	○
Hydraulic kit with two pumps with tank	A2ZZU	○	○	○	○	○	○	○
Buffer tank and pump for internal loop	BUF4A	○	○	○	○	○	○	○
Hydraulic kit with one pump for heat recovery	A1NTR	○	○	○	○	○	○	○
Hydraulic kit with higher available pressure pump for heat recovery	A1HPR	○	○	○	○	○	○	○
Hydraulic kit with two pump for heat recovery	A2NTR	○	○	○	○	○	○	○
Antifreeze kit in combination with A1VSU / A1NTU / A1HPU *	KPU1	○	○	○	○	○	○	○
Antifreeze kit in combination with A2NTU *	KPU2	○	○	○	○	○	○	○
Antifreeze kit in combination with pump and buffer tank *	KPSU1	○	○	○	○	○	○	○
Antifreeze kit in combination with pumps and buffer tank *	KPSU2	○	○	○	○	○	○	○
Antifreeze kit in combination with A1NTR / A1HPR	KPR1	○	○	○	○	○	○	○
Antifreeze kit in combination with A2NTR	KPR2	○	○	○	○	○	○	○

\* Includes accessory RAEV2

● Standard ○ Optional – Not available

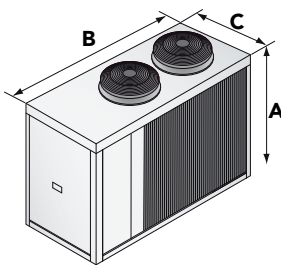

SE/LS 532  
SE/XL 532

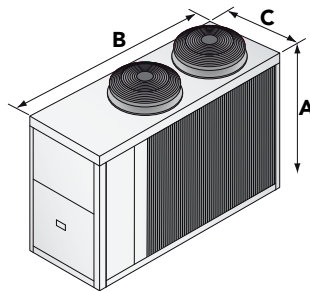

SE/LS 632 - 742  
SE/XL 632

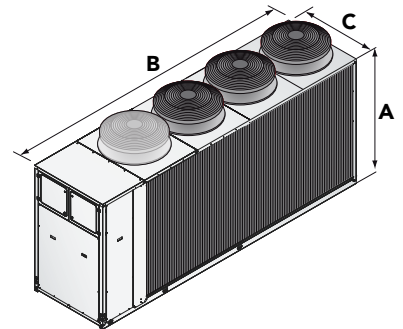

SE/LS 862 - 912 - 1052 - 1222  
SE/XL 742 - 862 - 912 - 1052 - 1222

		532	632	742	862	912	1052	1222
A (mm)	SE/LS	1690	1840	1840	1840	1840	1840	1840
B (mm)	SE/LS	2400	2905	2905	3905	3905	3905	3905
C (mm)	SE/LS	1145	1145	1145	1145	1145	1145	1145
kg	SE/LS	810	940	950	970	1270	1360	1410
A (mm)	SE/XL	1690	1840	1840	1840	1840	1840	1840
B (mm)	SE/XL	2400	2905	3905	3905	3905	3905	3905
C (mm)	SE/XL	1145	1145	1145	1145	1145	1145	1145
kg	SE/XL	830	960	970	990	1290	1380	1430

LHi SE/HH-RV	P4S/P4U	1534	1654	1854	1964	2254	2554
Flow switch		●	●	●	●	●	●
"Floating frame" Technology - XL Version		-	-	-	-	-	-
E.C. fans - SE versions	VECE	●	●	●	●	●	●
Condensate discharge drip tray with antifreeze heater	BRCA	○	○	○	○	○	○
Antifreeze kit for 4 pipe units	RAEV4	○	○	○	○	○	○
Electronic soft starter	DSSE	○	○	○	○	○	○
Serial interface card RS485	INSE	●	●	●	●	●	●
Rubber anti-vibration mountings	KAVG	○	○	○	○	○	○
Remote control panel	PCRL	○	○	○	○	○	○
Electronic expansion valve	VTEE	●	●	●	●	●	●
Power factor correction system	RICO	○	○	○	○	○	○
Power factor correction system with soft starter	RICSS	○	○	○	○	○	○
Spring vibration dampers	KAVM	○	○	○	○	○	○
Coil protection grid	GBPE	○	○	○	○	○	○
Shut-off valve on compressor discharging side	RDCO	○	○	○	○	○	○
Shut-off valve on compressor suction side	RHCO	○	○	○	○	○	○
Hydraulic kit with one inverter pump	A1VSU	○	○	○	○	○	○
Hydraulic kit with one pump without tank	A1NTU	○	○	○	○	○	○
Hydraulic kit with one higher available pressure pump	A1HPU	○	○	○	○	○	○
Hydraulic kit with two pumps without tank	A2NTU	○	○	○	○	○	○
Hydraulic kit with tank and one inverter pump	A1VVU	○	○	○	○	○	○
Hydraulic kit with one pump with tank	A1ZZU	○	○	○	○	○	○
Hydraulic kit with tank and one one higher available pressure pump	A1HHU	○	○	○	○	○	○
Hydraulic kit with two pumps with tank	A2ZZU	○	○	○	○	○	○
Buffer tank and pump for internal loop	BUF4A	○	○	○	○	○	○
Hydraulic kit with one pump for heat recovery	A1NTR	○	○	○	○	○	○
Hydraulic kit with higher available pressure pump for heat recovery	A1HPR	○	○	○	○	○	○
Hydraulic kit with two pump for heat recovery	A2NTR	○	○	○	○	○	○
Antifreeze kit in combination with A1VSU / A1NTU / A1HPU *	KPU1	○	○	○	○	○	○
Antifreeze kit in combination with A2NTU *	KPU2	○	○	○	○	○	○
Antifreeze kit in combination with pump and buffer tank *	KPSU1	○	○	○	○	○	○
Antifreeze kit in combination with pumps and buffer tank *	KPSU2	○	○	○	○	○	○
Antifreeze kit in combination with A1NTR / A1HPR	KPR1	○	○	○	○	○	○
Antifreeze kit in combination with A2NTR	KPR2	○	○	○	○	○	○

\* Includes accessory RAEV2

● Standard ○ Optional - Not available

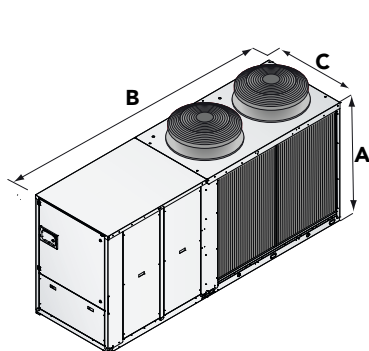

**SE/LS 1534**  
**SE/XL 1534**

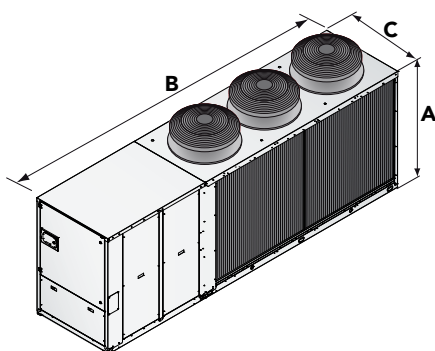

**SE/LS 1654 - 1854 - 1964**  
**SE/XL 1654 - 1854 - 1964**

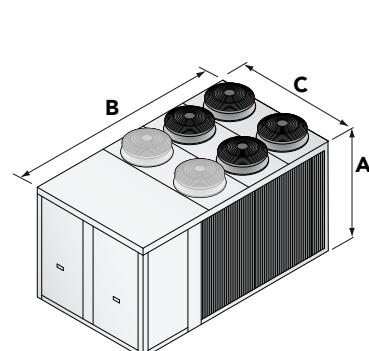

**SE/LS 2254 - 2554**  
**SE/XL 2254 - 2554**

		1534	1654	1854	1964	2254	2554
A (mm)	<b>SE/LS</b>	1890	1890	1890	1890	2350	2350
B (mm)	<b>SE/LS</b>	3695	4695	4695	4695	4205	4205
C (mm)	<b>SE/LS</b>	1145	1145	1145	1145	2190	2190
	<b>SE/LS</b>	1460	1810	1830	2130	2680	2720
A (mm)	<b>SE/XL</b>	1890	1890	1890	1890	2350	2350
B (mm)	<b>SE/XL</b>	3695	4695	4695	4695	4205	4205
C (mm)	<b>SE/XL</b>	1145	1145	1145	1145	2190	2190
	<b>SE/XL</b>	1480	1830	1850	2150	2700	2740

# LHNP4

## HIGH EFFICIENCY AIR TO WATER MULTIPURPOSE UNIT AND 4 PIPE HEAT PUMPS EQUIPPED WITH SCROLL COMPRESSOR AND AXIAL FANS

Heating capacity from 22 kW to 432 kW

R410A

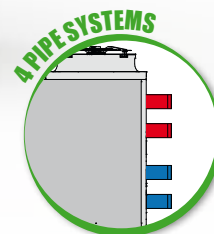
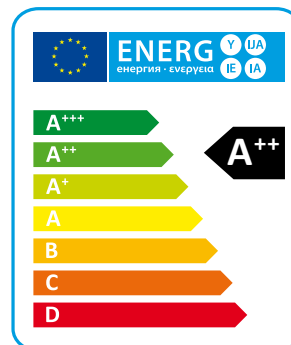

The high efficiency air / water heat pumps of the LHA series are units designed for 4-pipe air conditioning and heating systems, which allow the production of cold water for cooling and hot water for heating at the same time or separately.

The units are supplied with an additional exchanger, used as a condenser for hot water, the production of which is independent of the operation mode of the unit.

Activation of the exchanger takes place automatically via the microprocessor control when the hot water temperature on the return is lower than the set point. These units are able to produce hot water and cold water simultaneously and / or separately with very high energy efficiencies.

They are all supplied complete with a specific advanced microprocessor control provided with software for managing the various priorities.

The XL versions also have an extremely low noise level thanks to the use of a special floating vibration damping system that allows a noise reduction of about 6-8 dB (A) (optional).

### VERSIONS

- P4U** 4 pipe systems heating/cooling.
- P4S** 2+2 pipe systems with D.H.W. production.
- SA** Standard efficiency, AC fans.
- SE** Standard efficiency, EC fans.
- HA** High efficiency, AC fans.
- HE** High efficiency, EC fans.
- LS** Low noise.
- XL** Super low noise.

# TECHNICAL DATA

Reversible heating/cooling version (RV)

SA/LS/RV - P4S	242	292	402	432	492	592	702	802	902	1002	1202	1402	
Heating capacity (EN14511) <sup>(1)</sup> kW	22,0	28,7	34,5	47,2	50,9	56,8	64,9	73,2	80,2	97,0	105,7	122,3	
Total input power (EN14511) <sup>(1)</sup> kW	5,8	7,3	9,1	12,2	12,6	14,4	16,0	17,9	20,8	24,3	27,3	30,7	
COP (EN14511) <sup>(1)</sup>	W/W	3,83	3,93	3,80	3,86	4,04	3,94	4,06	4,10	3,86	4,00	3,87	
Energy Class <sup>(2)</sup>		A+	A+	A+	A+	A+	A+	A+	A+	A+	A+	A+	
SCOP <sup>(2)</sup>	kWh/kWh	3,27	3,58	3,41	3,34	3,48	3,54	3,43	3,47	3,42	3,50	3,39	
$\eta_{s,h}$ <sup>(2)</sup>	%	127,9	140,1	133,3	130,4	136,3	138,6	134,3	135,9	133,7	137,1	132,7	
Cooling capacity (EN14511) <sup>(3)</sup> kW	17,8	24,1	28,4	38,8	42,7	48,2	55,2	60,2	69,7	83,3	91,6	102,6	
Total input power (EN14511) <sup>(3)</sup> kW	7,1	9,8	11,7	15,0	16,4	19,8	21,9	24,5	29,3	32,7	37,7	42,6	
EER (EN14511) <sup>(3)</sup>	W/W	2,52	2,45	2,42	2,58	2,61	2,43	2,52	2,46	2,38	2,55	2,43	
TER (EN14511) <sup>(4)</sup>	W/W	8,76	9,43	9,02	8,58	9,28	9,55	9,58	9,29	9,13	9,34	9,14	
Sound power <sup>(5)</sup>	dB (A)	75	75	75	75	77	77	77	78	79	82	83	
Sound pressure <sup>(6)</sup>	dB (A)	43	43	43	43	45	45	45	46	47	50	51	
<b>SE/LS/RV - P4S</b>	<b>242</b>	<b>292</b>	<b>402</b>	<b>432</b>	<b>492</b>	<b>592</b>	<b>702</b>	<b>802</b>	<b>902</b>	<b>1002</b>	<b>1202</b>	<b>1402</b>	
Heating capacity (EN14511) <sup>(1)</sup> kW	21,9	28,6	34,2	47,1	51,1	57,1	64,9	73,1	81,0	97,0	105,6	122,7	
Total input power (EN14511) <sup>(1)</sup> kW	5,6	7,2	8,8	11,9	12,4	14,4	15,8	17,6	20,9	24,0	27,3	30,5	
COP (EN14511) <sup>(1)</sup>	W/W	3,92	3,95	3,87	3,95	4,13	3,97	4,10	4,15	3,88	4,04	3,87	
Energy Class <sup>(2)</sup>		A+	A+	A+	A+	A+	A+	A+	A+	A+	A+	A+	
SCOP <sup>(2)</sup>	kWh/kWh	3,40	3,66	3,53	3,46	3,59	3,62	3,68	3,71	3,63	3,71	3,64	
$\eta_{s,h}$ <sup>(2)</sup>	%	132,8	143,2	138,3	135,5	140,4	141,7	144,1	145,4	142,1	145,3	142,5	
Cooling capacity (EN14511) <sup>(3)</sup> kW	17,7	24,1	28,2	39,0	43,5	48,9	55,6	61,3	70,3	84,3	92,0	103,5	
Total input power (EN14511) <sup>(3)</sup> kW	7,0	9,8	11,8	14,9	16,0	19,5	21,8	24,0	28,9	32,3	37,4	42,2	
EER (EN14511) <sup>(3)</sup>	W/W	2,52	2,47	2,40	2,61	2,72	2,51	2,55	2,55	2,43	2,61	2,46	
TER (EN14511) <sup>(4)</sup>	W/W	8,76	9,43	9,02	8,58	9,28	9,55	9,58	9,29	9,13	9,34	9,14	
Sound power <sup>(5)</sup>	dB (A)	74	74	75	75	77	77	78	79	82	83	85	
Sound pressure <sup>(6)</sup>	dB (A)	42	42	43	43	45	45	46	47	50	51	53	
Power supply	V/Ph/Hz	400/3+N/50 400/3+N/50 400/3+N/50 400/3/50 400/3/50 400/3/50 400/3/50 400/3/50 400/3/50 400/3/50 400/3/50 400/3/50 400/3/50											
Compressors / Circuits	n° / n°	2 / 1	2 / 1	2 / 1	2 / 1	2 / 1	2 / 1	2 / 1	2 / 1	2 / 1	2 / 1	2 / 1	
Fans	n°	1	1	2	2	2	2	2	2	3	3	3	
Refrigerant		R410A	R410A	R410A	R410A	R410A	R410A	R410A	R410A	R410A	R410A	R410A	
Refrigerant charge	kg	10,0	10,0	10,0	10,0	14,5	14,5	14,5	14,5	14,5	21,0	27,0	
Global warming potential (GWP)		2088	2088	2088	2088	2088	2088	2088	2088	2088	2088	2088	
Equivalent CO <sub>2</sub> charge	t	20,88	20,88	20,88	20,88	30,27	30,27	30,27	30,27	30,27	43,84	56,37	
Water tank volume	l	100	100	100	100	100	100	300	300	300	500	500	

SA/LS/RV - P4S	1602	1802	2002	2302	2502	2504	3004	3204	3504	4004	4504	5004 *	
Heating capacity (EN14511) <sup>(1)</sup> kW	136,0	157,3	169,0	196,6	215,0	211,8	226,1	258,8	330,6	357,4	393,3	431,7	
Total input power (EN14511) <sup>(1)</sup> kW	34,6	40,3	43,4	51,5	60,4	58,2	64,8	71,9	85,2	93,8	103,0	116,4	
COP (EN14511) <sup>(1)</sup>	W/W	3,93	3,90	3,89	3,82	3,56	3,64	3,49	3,60	3,88	3,81	3,71	
Energy Class <sup>(2)</sup>		A+	A+	A+	A+	A+	A+	A+	A+	A+	A+	A+	
SCOP <sup>(2)</sup>	kWh/kWh	3,50	3,48	3,46	3,45	3,24	3,25	3,23	3,26	3,25	3,27	3,24	
$\eta_{s,h}$ <sup>(2)</sup>	%	137,0	136,1	135,5	134,8	126,5	127,1	126,1	127,2	127,0	127,8	130,4	
Cooling capacity (EN14511) <sup>(3)</sup> kW	115,6	131,9	143,0	173,0	197,2	192,3	210,8	231,8	286,3	312,9	349,4	401,8	
Total input power (EN14511) <sup>(3)</sup> kW	47,2	53,8	63,6	68,9	76,7	76,0	87,5	97,8	106,0	121,8	138,1	153,4	
EER (EN14511) <sup>(3)</sup>	W/W	2,45	2,45	2,25	2,51	2,57	2,53	2,41	2,37	2,70	2,57	2,62	
TER (EN14511) <sup>(4)</sup>	W/W	9,25	9,33	9,39	9,34	9,40	9,06	8,97	8,94	9,42	9,50	9,24	
Sound power <sup>(5)</sup>	dB (A)	86	86	86	89	90	87	89	90	90	92	93	
Sound pressure <sup>(6)</sup>	dB (A)	54	54	54	57	58	55	57	58	58	60	61	
<b>SE/LS/RV - P4S</b>	<b>1602</b>	<b>1802</b>	<b>2002</b>	<b>2302</b>	<b>2502</b>	<b>2504</b>	<b>3004</b>	<b>3204</b>	<b>3504</b>	<b>4004</b>	<b>4504</b>	<b>5004 *</b>	
Heating capacity (EN14511) <sup>(1)</sup> kW	137,0	157,8	170,2	197,7	217,6	213,2	227,7	261,7	330,6	357,5	396,6	435,4	
Total input power (EN14511) <sup>(1)</sup> kW	34,6	38,8	43,3	51,5	60,3	57,9	65,1	71,9	82,9	92,1	102,7	116,7	
COP (EN14511) <sup>(1)</sup>	W/W	3,96	4,07	3,93	3,84	3,61	3,68	3,50	3,64	3,99	3,88	3,73	
Energy Class <sup>(2)</sup>		A+	A+	A+	A+	A+	A+	A+	A+	A+	A+	A+	
SCOP <sup>(2)</sup>	kWh/kWh	3,68	3,77	3,72	3,74	3,63	3,54	3,49	3,46	3,52	3,57	3,58	
$\eta_{s,h}$ <sup>(2)</sup>	%	144,0	147,8	145,8	146,4	142,1	138,6	136,5	135,2	137,9	139,6	142,3	
Cooling capacity (EN14511) <sup>(3)</sup> kW	116,4	132,9	147,1	175,3	200,4	195,8	212,1	233,3	289,3	321,1	357,3	408,0	
Total input power (EN14511) <sup>(3)</sup> kW	46,9	53,4	61,0	67,9	75,6	74,4	86,9	96,8	104,8	118,1	135,9	150,0	
EER (EN14511) <sup>(3)</sup>	W/W	2,48	2,49	2,41	2,58	2,65	2,63	2,44	2,41	2,76	2,72	2,72	
TER (EN14511) <sup>(4)</sup>	W/W	9,25	9,33	9,39	9,34	9,40	9,06	8,97	8,94	9,42	9,50	9,24	
Sound power <sup>(5)</sup>	dB (A)	86	86	86	89	90	87	89	90	90	92	93	
Sound pressure <sup>(6)</sup>	dB (A)	54	54	54	57	58	55	57	58	58	60	61	
Power supply	V/Ph/Hz	400/3/50 400/3/50 400/3/50 400/3/50 400/3/50 400/3/50 400/3/50 400/3/50 400/3/50 400/3/50 400/3/50 400/3/50											
Compressors / Circuits	n° / n°	2 / 1	2 / 1	2 / 1	2 / 1	2 / 1	4 / 2	4 / 2	4 / 2	4 / 2	4 / 2	4 / 2	
Fans	n°	4	4	4	3	4	4	4	4	6	6	8	
Refrigerant		R410A	R410A	R410A	R410A	R410A	R410A	R410A	R410A	R410A	R410A	R410A	
Refrigerant charge	kg	27,0	36,0	36,0	45,0	45,0	45,0	54,0	54,0	72,0	80,0	100,0	
Global warming potential (GWP)		2088	2088	2088	2088	2088	2088	2088	2088	2088	2088	2088	
Equivalent CO <sub>2</sub> charge	t	56,37	75,16	75,16	93,96	93,96	93,96	112,75	112,75	150,33	167,04	208,80	
Water tank volume	l	500	500	500	500	500	500	500	1000	1000	1000	1000	

\* Units only available for the non-EU market

Performances are referred to the following conditions:

(1) Heating: Ambient temperature 7°C DB, 6°C WB, water temperature 30/35°C.

(2) Average conditions, low temperature, variable - Reg EU 811/2013

(3) Cooling: ambient air temperature 35°C, evaporator water temperature in/out 12/7 °C.

(4) TER: Total Energy Ratio - cold circuit 12/7°C, hot circuit 30/35°C.

(5) Sound power level in accordance with ISO 3744.

(6) Sound pressure level at 10 mt from the unit in free field conditions in accordance with ISO 3744.

Reversible heating/cooling version (RV)

SA/LS/RV - P4U	242	292	402	432	492	592	702	802	902	1002	1202	1402	
Heating capacity (EN14511) <sup>(1)</sup> kW	22,0	28,7	34,5	47,2	50,9	56,8	67,0	75,4	82,6	101,0	107,9	125,9	
Total input power (EN14511) <sup>(1)</sup> kW	5,8	7,3	9,1	12,2	12,6	14,4	16,1	18,0	21,0	24,5	27,5	31,0	
COP (EN14511) <sup>(1)</sup>	W/W	3,83	3,93	3,80	3,86	4,04	3,94	4,17	4,19	3,94	4,12	3,92	
Energy Class <sup>(2)</sup>		A+	A+	A+	A+	A+	A+	A+	A+	A+	A+	A+	
SCOP <sup>(2)</sup>	kWh/kWh	3,27	3,58	3,41	3,34	3,48	3,54	3,50	3,54	3,52	3,58	3,46	
η <sub>s,h</sub> <sup>(2)</sup>	%	127,9	140,1	133,3	130,4	136,3	138,6	137,1	138,5	137,9	140,0	135,4	
Cooling capacity (EN14511) <sup>(3)</sup> kW	17,8	24,1	28,4	38,8	42,7	48,2	55,2	60,2	69,7	83,3	91,6	102,6	
Total input power (EN14511) <sup>(3)</sup> kW	7,1	9,8	11,7	15,0	16,4	19,8	21,9	24,5	29,3	32,7	37,7	42,6	
EER (EN14511) <sup>(3)</sup>	W/W	2,52	2,45	2,42	2,58	2,61	2,43	2,52	2,46	2,38	2,55	2,43	
TER (EN14511) <sup>(4)</sup>	W/W	8,76	9,43	9,02	8,58	9,28	9,55	9,58	9,29	9,13	9,34	9,14	
Sound power <sup>(5)</sup>	dB (A)	75	75	75	75	77	77	77	78	79	82	83	
Sound pressure <sup>(6)</sup>	dB (A)	43	43	43	43	45	45	45	46	47	50	51	
SE/LS/RV - P4U	242	292	402	432	492	592	702	802	902	1002	1202	1402	
Heating capacity (EN14511) <sup>(1)</sup> kW	21,9	28,6	34,2	47,1	51,1	57,1	67,2	75,7	83,5	101,3	108,7	126,6	
Total input power (EN14511) <sup>(1)</sup> kW	5,6	7,2	8,8	11,9	12,4	14,4	16,0	17,9	21,0	24,3	27,5	30,9	
COP (EN14511) <sup>(1)</sup>	W/W	3,92	3,95	3,87	3,95	4,13	3,97	4,20	4,23	3,98	4,17	3,96	
Energy Class <sup>(2)</sup>		A+	A+	A+	A+	A+	A+	A+	A+	A++	A+	A++	
SCOP <sup>(2)</sup>	kWh/kWh	3,40	3,66	3,53	3,46	3,59	3,62	3,77	3,80	3,72	3,79	3,73	
η <sub>s,h</sub> <sup>(2)</sup>	%	132,8	143,2	138,3	135,5	140,4	141,7	147,7	148,9	145,6	148,6	146,2	
Cooling capacity (EN14511) <sup>(3)</sup> kW	17,7	24,1	28,2	39,0	43,5	48,9	55,6	61,3	70,3	84,3	92,0	103,5	
Total input power (EN14511) <sup>(3)</sup> kW	7,0	9,8	11,8	14,9	16,0	19,5	21,8	24,0	28,9	32,3	37,4	42,2	
EER (EN14511) <sup>(3)</sup>	W/W	2,52	2,47	2,40	2,61	2,72	2,51	2,55	2,55	2,43	2,61	2,46	
TER (EN14511) <sup>(4)</sup>	W/W	8,76	9,43	9,02	8,58	9,28	9,55	9,58	9,29	9,13	9,34	9,14	
Sound power <sup>(5)</sup>	dB (A)	74	74	75	75	77	77	78	79	82	83	85	
Sound pressure <sup>(6)</sup>	dB (A)	42	42	43	43	45	45	46	47	50	51	53	
Power supply	V/Ph/Hz	400/3+N/50 400/3+N/50 400/3+N/50 400/3/50 400/3/50 400/3/50 400/3/50 400/3/50 400/3/50 400/3/50 400/3/50 400/3/50 400/3/50											
Compressors / Circuits	n° / n°	2 / 1	2 / 1	2 / 1	2 / 1	2 / 1	2 / 1	2 / 1	2 / 1	2 / 1	2 / 1	2 / 1	
Fans	n°	1	1	2	2	2	2	2	2	3	3	3	
Refrigerant		R410A	R410A	R410A	R410A	R410A	R410A	R410A	R410A	R410A	R410A	R410A	
Refrigerant charge	kg	10,0	10,0	10,0	10,0	14,5	14,5	14,5	14,5	14,5	21,0	27,0	
Global warming potential (GWP)		2088	2088	2088	2088	2088	2088	2088	2088	2088	2088	2088	
Equivalent CO <sub>2</sub> charge	t	20,88	20,88	20,88	20,88	30,27	30,27	30,27	30,27	30,27	43,84	56,37	
Water tank volume	l	100	100	100	100	100	100	300	300	300	500	500	

SA/LS/RV - P4U	1602	1802	2002	2302	2502	2504	3004	3204	3504	4004	4504	5004 *	
Heating capacity (EN14511) <sup>(1)</sup> kW	140,0	161,8	173,5	202,7	222,9	218,3	234,8	268,5	341,0	369,9	393,3	444,9	
Total input power (EN14511) <sup>(1)</sup> kW	35,0	39,4	43,6	51,9	59,1	59,5	66,2	73,6	85,4	93,8	103,0	118,7	
COP (EN14511) <sup>(1)</sup>	W/W	4,00	4,11	3,98	3,90	3,77	3,67	3,55	3,65	3,99	3,94	3,82	
Energy Class <sup>(2)</sup>		A+	A+	A+	A+	A+	A+	A+	A+	A+	A+	A+	
SCOP <sup>(2)</sup>	kWh/kWh	3,57	3,54	3,54	3,51	3,39	3,30	3,27	3,28	3,33	3,34	3,28	
η <sub>s,h</sub> <sup>(2)</sup>	%	139,6	138,4	138,4	137,4	132,5	128,8	127,7	128,3	130,2	130,6	128,0	
Cooling capacity (EN14511) <sup>(3)</sup> kW	115,6	131,9	143,0	173,0	197,2	192,3	210,8	231,8	286,3	312,9	349,4	401,8	
Total input power (EN14511) <sup>(3)</sup> kW	47,2	53,8	63,6	68,9	76,7	76,0	87,5	97,8	106,0	121,8	138,1	153,4	
EER (EN14511) <sup>(3)</sup>	W/W	2,45	2,45	2,25	2,51	2,57	2,53	2,41	2,37	2,70	2,53	2,62	
TER (EN14511) <sup>(4)</sup>	W/W	9,25	9,33	9,39	9,34	9,40	9,06	8,97	8,94	9,42	9,50	9,24	
Sound power <sup>(5)</sup>	dB (A)	86	86	86	89	90	87	89	90	90	90	92	
Sound pressure <sup>(6)</sup>	dB (A)	54	54	54	57	58	55	57	58	58	58	60	
SE/LS/RV - P4U	1602	1802	2002	2302	2502	2504	3004	3204	3504	4004	4504	5004 *	
Heating capacity (EN14511) <sup>(1)</sup> kW	141,2	163,4	175,6	204,4	224,8	219,9	236,7	272,7	339,6	371,9	396,6	449,7	
Total input power (EN14511) <sup>(1)</sup> kW	35,0	39,3	43,6	52,0	59,1	59,4	66,3	73,8	83,0	92,3	102,7	118,8	
COP (EN14511) <sup>(1)</sup>	W/W	4,04	4,16	4,03	3,93	3,80	3,70	3,57	3,70	4,09	4,03	3,86	
Energy Class <sup>(2)</sup>		A+	A++	A+	A+	A+	A+	A+	A+	A+	A+	A+	
SCOP <sup>(2)</sup>	kWh/kWh	3,77	3,84	3,78	3,82	3,80	3,56	3,51	3,48	3,63	3,66	3,64	
η <sub>s,h</sub> <sup>(2)</sup>	%	147,6	150,5	148,3	149,9	149,1	139,2	137,4	136,3	142,1	143,3	142,6	
Cooling capacity (EN14511) <sup>(3)</sup> kW	116,4	132,9	147,1	175,3	200,4	195,8	212,1	233,3	289,3	321,1	357,3	408,0	
Total input power (EN14511) <sup>(3)</sup> kW	46,9	53,4	61,0	67,9	75,6	74,4	86,9	96,8	104,8	118,1	135,9	150,0	
EER (EN14511) <sup>(3)</sup>	W/W	2,48	2,49	2,41	2,58	2,65	2,63	2,44	2,41	2,76	2,72	2,63	
TER (EN14511) <sup>(4)</sup>	W/W	9,25	9,33	9,39	9,34	9,40	9,06	8,97	8,94	9,42	9,50	9,24	
Sound power <sup>(5)</sup>	dB (A)	86	86	86	89	90	87	89	90	90	90	92	
Sound pressure <sup>(6)</sup>	dB (A)	54	54	54	57	58	55	57	58	58	58	60	
Power supply	V/Ph/Hz	400/3/50 400/3/50 400/3/50 400/3/50 400/3/50 400/3/50 400/3/50 400/3/50 400/3/50 400/3/50 400/3/50 400/3/50 400/3/50											
Compressors / Circuits	n° / n°	2 / 1	2 / 1	2 / 1	2 / 1	2 / 1	4 / 2	4 / 2	4 / 2	4 / 2	4 / 2	4 / 2	
Fans	n°	4	4	4	3	4	4	4	6	6	6	8	
Refrigerant		R410A	R410A	R410A	R410A	R410A	R410A	R410A	R410A	R410A	R410A	R410A	
Refrigerant charge	kg	27,0	36,0	36,0	45,0	45,0	45,0	54,0	54,0	72,0	80,0	100,0	
Global warming potential (GWP)		2088	2088	2088	2088	2088	2088	2088	2088	2088	2088	2088	
Equivalent CO <sub>2</sub> charge	t	56,37	75,16	75,16	93,96	93,96	93,96	112,75	112,75	150,33	167,04	208,80	
Water tank volume	l	500	500	500	500	500	500	500	1000	1000	1000	1000	

\* Units only available for the non-EU market

Performances are referred to the following conditions:

- (1) Heating: Ambient temperature 7°C DB, 6°C WB, water temperature 30/35°C.
- (2) Average conditions, low temperature, variable - Reg EU 811/2013
- (3) Cooling: ambient air temperature 35°C, evaporator water temperature in/out 12/7 °C.

(4) TER: Total Energy Ratio - cold circuit 12/7°C, hot circuit 30/35°C.

(5) Sound power level in accordance with ISO 3744.

(6) Sound pressure level at 10 mt from the unit in free field conditions in accordance with ISO 3744.

Reversible heating/cooling version (RV)

HA/LS/RV - P4S	242	292	412	432	492	602	702	802	902	1002	1202	1402
Heating capacity (EN14511) <sup>(1)</sup> kW	22,2	29,6	37,3	46,9	50,7	61,2	67,3	72,6	93,1	104,7	114,4	137,2
Total input power (EN14511) <sup>(1)</sup> kW	5,4	7,2	9,0	11,4	12,0	13,6	15,4	17,0	22,1	25,3	28,4	32,4
COP (EN14511) <sup>(1)</sup>	W/W 4,11	4,12	4,13	4,11	4,22	4,49	4,38	4,27	4,21	4,14	4,03	4,24
Energy Class <sup>(2)</sup>	A+	A+	A+	A+	A+	A++	A++	A++	A+	A+	A+	A+
SCOP <sup>(2)</sup>	kWh/kWh 3,40	3,69	3,53	3,57	3,67	3,97	3,91	3,87	3,70	3,67	3,69	3,70
η <sub>s,h</sub> <sup>(2)</sup>	% 132,9	144,7	138,0	139,6	143,8	155,7	153,4	151,6	145,1	143,7	144,4	144,8
Cooling capacity (EN14511) <sup>(3)</sup> kW	18,1	24,5	30,8	39,9	44,2	52,3	57,4	62,6	79,8	89,6	97,8	117,0
Total input power (EN14511) <sup>(3)</sup> kW	7,0	9,6	10,9	15,0	16,3	18,4	21,5	24,5	27,2	31,7	36,5	43,8
EER (EN14511) <sup>(3)</sup>	W/W 2,57	2,56	2,84	2,65	2,72	2,84	2,67	2,55	2,93	2,83	2,68	2,67
TER (EN14511) <sup>(4)</sup>	W/W 9,05	9,43	9,56	9,54	10,41	10,48	10,42	10,43	9,84	9,63	9,46	9,91
Sound power <sup>(5)</sup>	dB (A) 75	75	75	75	76	76	77	78	82	83	85	86
Sound pressure <sup>(6)</sup>	dB (A) 43	43	43	43	44	44	45	46	50	51	53	54
HE/LS/RV - P4S	242	292	412	432	492	602	702	802	902	1002	1202	1402
Heating capacity (EN14511) <sup>(1)</sup> kW	22,2	29,6	37,3	47,1	50,8	61,2	67,3	74,9	93,2	104,9	114,9	137,1
Total input power (EN14511) <sup>(1)</sup> kW	5,3	7,1	8,8	11,5	11,8	13,3	15,1	17,2	21,2	24,5	27,8	30,9
COP (EN14511) <sup>(1)</sup>	W/W 4,11	4,16	4,23	4,11	4,32	4,61	4,46	4,36	4,40	4,29	4,13	4,44
Energy Class <sup>(2)</sup>	A++	A++	A++	A++	A++	A++	A++	A++	A++	A++	A++	A++
SCOP <sup>(2)</sup>	kWh/kWh 3,83	3,86	3,85	3,85	3,92	4,13	4,04	3,97	3,87	3,85	3,83	3,85
η <sub>s,h</sub> <sup>(2)</sup>	% 150,1	151,4	150,9	151,1	153,6	162,0	158,4	155,8	151,7	150,8	150,2	151,0
Cooling capacity (EN14511) <sup>(3)</sup> kW	18,1	25,4	30,5	40,6	44,2	52,4	57,5	65,4	80,5	90,2	100,5	117,4
Total input power (EN14511) <sup>(3)</sup> kW	6,9	8,4	11,0	14,5	16,1	18,3	21,3	22,8	26,6	31,2	35,1	38,6
EER (EN14511) <sup>(3)</sup>	W/W 2,62	3,02	2,78	2,81	2,74	2,87	2,70	2,87	3,03	2,89	2,86	3,04
TER (EN14511) <sup>(4)</sup>	W/W 9,05	9,63	9,56	9,54	10,41	10,48	10,42	10,5	9,84	9,63	9,46	9,91
Sound power <sup>(5)</sup>	dB (A) 73	74	74	75	76	76	77	78	82	83	85	86
Sound pressure <sup>(6)</sup>	dB (A) 41	42	42	43	44	44	45	46	50	51	53	54
Power supply	V/Ph/Hz	400/3+N/50	400/3+N/50	400/3/50	400/3/50	400/3/50	400/3/50	400/3/50	400/3/50	400/3/50	400/3/50	400/3/50
Compressors / Circuits	n° / n°	2 / 1	2 / 1	2 / 1	2 / 1	2 / 1	2 / 1	2 / 1	2 / 1	2 / 1	2 / 1	2 / 1
Fans	n°	1	1	2	2	2	2	2	2	2	2	3
Refrigerant		R410A	R410A	R410A	R410A	R410A	R410A	R410A	R410A	R410A	R410A	R410A
Refrigerant charge	kg	10,0	10,0	10,0	10,0	14,5	19,0	19,0	27,0	27,0	27,0	36,0
Global warming potential (GWP)		2088	2088	2088	2088	2088	2088	2088	2088	2088	2088	2088
Equivalent CO <sub>2</sub> charge	t	20,88	20,88	20,88	20,88	30,28	39,67	39,67	56,38	56,38	56,38	75,17
Water tank volume	l	100	100	100	100	100	300	300	300	300	300	500

HA/LS/RV - P4S	1602	1802	2002	2302	2502	2504	3004	3204	3504	4004	4504	5004 *
Heating capacity (EN14511) <sup>(1)</sup> kW	150,8	167,2	182,0	209,7	239,2	228,6	270,2	295,6	335,0	363,1	398,6	458,7
Total input power (EN14511) <sup>(1)</sup> kW	35,8	41,3	45,4	50,3	55,8	56,7	67,0	74,1	83,5	90,3	103,5	116,4
COP (EN14511) <sup>(1)</sup>	W/W 4,21	4,05	4,01	4,17	4,29	4,03	4,03	3,99	4,01	4,02	3,85	3,94
Energy Class <sup>(2)</sup>	A+	A+	A+	A+	A++	A+	A+	A+	A+	A+	A+	A+
SCOP <sup>(2)</sup>	kWh/kWh 3,74	3,69	3,62	3,76	3,83	3,65	3,63	3,65	3,66	3,73	3,61	3,63
η <sub>s,h</sub> <sup>(2)</sup>	% 146,4	144,7	141,9	147,3	150,3	143,1	142,0	142,9	143,3	146,1	141,4	142,0
Cooling capacity (EN14511) <sup>(3)</sup> kW	129,5	144,5	159,3	180,2	199,7	197,4	230,1	257,2	288,2	325,6	366,0	405,0
Total input power (EN14511) <sup>(3)</sup> kW	44,3	51,8	58,8	66,3	74,5	73,1	81,9	91,5	105,6	116,7	136,1	155,2
EER (EN14511) <sup>(3)</sup>	W/W 2,92	2,79	2,71	2,72	2,68	2,70	2,81	2,81	2,73	2,79	2,69	2,61
TER (EN14511) <sup>(4)</sup>	W/W 9,87	9,99	9,90	9,79	9,74	9,27	9,18	9,60	9,68	9,71	9,62	9,50
Sound power <sup>(5)</sup>	dB (A) 87	87	87	89	91	88	89	90	90	90	92	92
Sound pressure <sup>(6)</sup>	dB (A) 55	55	55	57	59	56	57	58	58	58	60	60
HE/LS/RV - P4S	1602	1802	2002	2302	2502	2504	3004	3204	3504	4004	4504	5004 *
Heating capacity (EN14511) <sup>(1)</sup> kW	151,0	167,9	182,8	210,6	241,3	229,4	271,4	296,7	339,0	364,9	399,1	463,7
Total input power (EN14511) <sup>(1)</sup> kW	34,4	40,2	45,5	49,4	54,8	55,8	63,9	71,5	83,7	88,8	102,1	115,1
COP (EN14511) <sup>(1)</sup>	W/W 4,39	4,18	4,02	4,26	4,40	4,11	4,25	4,15	4,05	4,11	3,91	4,03
Energy Class <sup>(2)</sup>	A++	A++	A++	A++	A++	A++	A++	A++	A++	A++	A++	A++
SCOP <sup>(2)</sup>	kWh/kWh 3,86	3,85	3,84	3,92	3,97	3,83	3,85	3,83	3,91	3,89	3,87	3,86
η <sub>s,h</sub> <sup>(2)</sup>	% 151,3	150,9	150,4	153,6	155,6	150,2	151,1	150,3	153,5	152,4	151,9	151,5
Cooling capacity (EN14511) <sup>(3)</sup> kW	129,5	146,8	159,2	180,4	202,1	198,5	231,0	259,7	289,4	322,6	368,5	416,0
Total input power (EN14511) <sup>(3)</sup> kW	44,0	50,8	58,7	66,1	73,2	72,7	80,5	89,2	105,2	118,2	135,0	154,6
EER (EN14511) <sup>(3)</sup>	W/W 2,94	2,89	2,71	2,73	2,76	2,73	2,87	2,91	2,75	2,73	2,73	2,69
TER (EN14511) <sup>(4)</sup>	W/W 9,87	9,99	9,90	9,79	9,74	9,27	9,18	9,60	9,68	9,71	9,62	9,50
Sound power <sup>(5)</sup>	dB (A) 87	87	87	89	91	88	89	90	90	90	92	92
Sound pressure <sup>(6)</sup>	dB (A) 55	55	55	57	59	56	57	58	58	58	60	60
Power supply	V/Ph/Hz	400/3/50	400/3/50	400/3/50	400/3/50	400/3/50	400/3/50	400/3/50	400/3/50	400/3/50	400/3/50	400/3/50
Compressors / Circuits	n° / n°	2 / 1	2 / 1	2 / 1	2 / 1	2 / 1	4 / 2	4 / 2	4 / 2	4 / 2	4 / 2	4 / 2
Fans	n°	3	3	3	3	3	4	6	6	6	8	8
Refrigerant		R410A	R410A	R410A	R410A	R410A	R410A	R410A	R410A	R410A	R410A	R410A
Refrigerant charge	kg	36,0	36,0	45,0	45,0	60,0	60,0	72,0	72,0	90,0	90,0	100,0
Global warming potential (GWP)		2088	2088	2088	2088	2088	2088	2088	2088	2088	2088	2088
Equivalent CO <sub>2</sub> charge	t	75,17	75,17	93,96	93,96	125,28	125,28	150,34	150,34	187,92	187,92	208,80
Water tank volume	l	500	500	500	500	500	1000	1000	1000	1000	1000	1000

\* Units only available for the non-EU market

Performances are referred to the following conditions:

- (1) Heating: Ambient temperature 7°C DB, 6°C WB, water temperature 30/35°C.
- (2) Average conditions, low temperature, variable - Reg EU 811/2013
- (3) Cooling: ambient air temperature 35°C, evaporator water temperature in/out 12/7 °C.

(4) TER: Total Energy Ratio - cold circuit 12/7°C, hot circuit 30/35°C.

(5) Sound power level in accordance with ISO 3744.

(6) Sound pressure level at 10 mt from the unit in free field conditions in accordance with ISO 3744.

Reversible heating/cooling version (RV)

HA/LS/RV - P4U	242	292	412	432	492	602	702	802	902	1002	1202	1402
Heating capacity (EN14511) <sup>(1)</sup> kW	22,9	30,5	37,3	46,9	50,7	63,6	69,6	75,0	96,6	108,3	118,1	142,2
Total input power (EN14511) <sup>(1)</sup> kW	5,6	7,3	9,0	11,4	12,0	13,7	15,5	17,1	22,3	25,5	28,7	32,6
COP (EN14511) <sup>(1)</sup>	W/W	4,11	4,20	4,13	4,11	4,22	4,64	4,50	4,33	4,24	4,11	4,36
Energy Class <sup>(2)</sup>		A+	A+	A+	A+	A+	A++	A++	A++	A+	A+	A+
SCOP <sup>(2)</sup>	kWh/kWh	3,47	3,76	3,53	3,57	3,67	4,04	4,00	3,95	3,76	3,73	3,78
η <sub>s,h</sub> <sup>(2)</sup>	%	135,7	147,4	138,0	139,6	143,8	158,5	156,8	155,0	147,4	146,1	148,3
Cooling capacity (EN14511) <sup>(3)</sup> kW	18,1	24,5	30,8	39,9	44,2	52,3	57,4	62,6	79,8	89,6	97,8	117,0
Total input power (EN14511) <sup>(3)</sup> kW	7,0	9,6	10,9	15,0	16,3	18,4	21,5	24,5	27,2	31,7	36,5	43,8
EER (EN14511) <sup>(3)</sup>	W/W	2,57	2,56	2,84	2,65	2,72	2,84	2,67	2,55	2,93	2,83	2,68
TER (EN14511) <sup>(4)</sup>	W/W	9,05	9,43	9,56	9,54	10,41	10,48	10,42	10,43	9,84	9,63	9,46
Sound power <sup>(5)</sup>	dB (A)	75	75	75	75	76	76	77	78	82	83	85
Sound pressure <sup>(6)</sup>	dB (A)	43	43	43	43	44	44	45	46	50	51	53
Power supply	V/Ph/Hz	400/3+N/50	400/3+N/50	400/3/50	400/3/50	400/3/50	400/3/50	400/3/50	400/3/50	400/3/50	400/3/50	400/3/50
Compressors / Circuits	n° / n°	2 / 1	2 / 1	2 / 1	2 / 1	2 / 1	2 / 1	2 / 1	2 / 1	2 / 1	2 / 1	2 / 1
Fans	n°	2	2	2	2	2	2	2	2	2	2	3
Refrigerant		R410A	R410A	R410A	R410A	R410A	R410A	R410A	R410A	R410A	R410A	R410A
Refrigerant charge	kg	10,0	10,0	10,0	10,0	14,5	19,0	19,0	19,0	27,0	27,0	36,0
Global warming potential (GWP)		2088	2088	2088	2088	2088	2088	2088	2088	2088	2088	2088
Equivalent CO <sub>2</sub> charge	t	20,88	20,88	20,88	20,88	30,28	39,67	39,67	39,67	56,38	56,38	75,17
Water tank volume	l	100	100	100	100	100	300	300	300	300	300	500

HA/LS/RV - P4U	1602	1802	2002	2302	2502	2504	3004	3204	3504	4004	4504	5004 *
Heating capacity (EN14511) <sup>(1)</sup> kW	156,2	173,5	188,7	216,2	247,7	235,9	279,5	306,4	337,5	372,8	398,6	474,8
Total input power (EN14511) <sup>(1)</sup> kW	36,0	40,5	45,3	50,6	56,1	58,1	68,5	74,6	83,5	92,1	103,5	118,9
COP (EN14511) <sup>(1)</sup>	W/W	4,34	4,28	4,17	4,27	4,41	4,06	4,08	4,11	4,04	4,05	3,99
Energy Class <sup>(2)</sup>		A+	A++	A+	A++	A++	A+	A+	A+	A+	A+	A+
SCOP <sup>(2)</sup>	kWh/kWh	3,81	3,83	3,77	3,85	3,96	3,68	3,63	3,74	3,74	3,75	3,66
η <sub>s,h</sub> <sup>(2)</sup>	%	149,2	150,0	147,8	151,0	155,5	144,2	142,2	146,5	146,6	146,8	143,5
Cooling capacity (EN14511) <sup>(3)</sup> kW	129,5	144,5	159,3	180,2	199,7	197,4	230,1	257,2	288,2	325,6	366,0	405,0
Total input power (EN14511) <sup>(3)</sup> kW	44,3	51,8	58,8	66,3	74,5	73,1	81,9	91,5	105,6	116,7	136,1	155,2
EER (EN14511) <sup>(3)</sup>	W/W	2,92	2,79	2,71	2,72	2,68	2,70	2,81	2,81	2,73	2,79	2,61
TER (EN14511) <sup>(4)</sup>	W/W	9,87	9,99	9,90	9,79	9,74	9,27	9,18	9,60	9,68	9,71	9,62
Sound power <sup>(5)</sup>	dB (A)	87	87	87	89	91	88	89	90	90	90	92
Sound pressure <sup>(6)</sup>	dB (A)	55	55	55	57	59	56	57	58	58	58	60
Power supply	V/Ph/Hz	400/3/50	400/3/50	400/3/50	400/3/50	400/3/50	400/3/50	400/3/50	400/3/50	400/3/50	400/3/50	400/3/50
Compressors / Circuits	n° / n°	2 / 1	2 / 1	2 / 1	2 / 1	2 / 1	4 / 2	4 / 2	4 / 2	4 / 2	4 / 2	4 / 2
Fans	n°	3	3	3	3	3	4	6	6	6	8	8
Refrigerant		R410A	R410A	R410A	R410A	R410A	R410A	R410A	R410A	R410A	R410A	R410A
Refrigerant charge	kg	36,0	36,0	45,0	45,0	60,0	60,0	72,0	72,0	90,0	90,0	100,0
Global warming potential (GWP)		2088	2088	2088	2088	2088	2088	2088	2088	2088	2088	2088
Equivalent CO <sub>2</sub> charge	t	75,16	75,16	93,96	93,96	125,28	125,28	150,33	150,33	150,33	187,92	208,80
Water tank volume	l	500	500	500	500	500	1000	1000	1000	1000	1000	1000

\* Units only available for the non-EU market

Performances are referred to the following conditions:

- (1) Heating: Ambient temperature 7°C DB, 6°C WB, water temperature 30/35°C.
- (2) Average conditions, low temperature, variable - Reg EU 811/2013
- (3) Cooling: ambient air temperature 35°C, evaporator water temperature in/out 12/7 °C.

(4) TER: Total Energy Ratio - cold circuit 12/7°C, hot circuit 30/35°C.

(5) Sound power level in accordance with ISO 3744.

(6) Sound pressure level at 10 mt from the unit in free field conditions in accordance with ISO 3744.

Reversible heating/cooling version (RV)

HA/XL/RV - P4S	252	302	412	432	492	602	702	802	902	1002	1202	1402
Heating capacity (EN14511) <sup>(1)</sup> kW	23,1	29,8	36,8	46,2	49,4	60,1	65,9	71,0	91,6	101,7	111,1	134,8
Total input power (EN14511) <sup>(1)</sup> kW	5,6	7,2	8,8	11,2	11,7	13,4	15,1	16,7	20,9	23,9	27,0	30,5
COP (EN14511) <sup>(1)</sup>	W/W	4,12	4,13	4,20	4,12	4,21	4,50	4,35	4,25	4,39	4,26	4,41
Energy Class <sup>(2)</sup>		A+	A+	A+	A+	A+	A++	A++	A++	A++	A++	A++
SCOP <sup>(2)</sup>	kWh/kWh	3,36	3,58	3,68	3,65	3,77	4,04	3,96	3,89	3,88	3,87	3,72
η <sub>s,h</sub> <sup>(2)</sup>	%	131,2	140,2	144,0	143,0	147,9	158,6	155,4	152,7	152,2	151,6	145,7
Cooling capacity (EN14511) <sup>(3)</sup> kW	19,5	24,7	29,7	38,9	42,8	50,4	55,7	60,3	78,1	86,4	94,1	114,3
Total input power (EN14511) <sup>(3)</sup> kW	7,2	9,7	11,2	15,4	16,7	19,1	22,0	25,1	26,7	31,5	36,8	39,0
EER (EN14511) <sup>(3)</sup>	W/W	2,72	2,55	2,65	2,54	2,57	2,64	2,53	2,40	2,74	2,56	2,93
TER (EN14511) <sup>(4)</sup>	W/W	9,44	9,43	9,56	9,54	10,41	10,48	10,42	10,43	9,84	9,63	9,46
Sound power <sup>(5)</sup>	dB (A)	70	70	70	70	72	72	72	73	75	76	80
Sound pressure <sup>(6)</sup>	dB (A)	38	38	38	38	40	40	40	41	43	44	48

HE/XL/RV - P4S	252	302	412	432	492	602	702	802	902	1002	1202	1402
Heating capacity (EN14511) <sup>(1)</sup> kW	23,1	29,8	36,9	46,3	49,7	60,0	65,9	71,0	91,4	101,4	111,0	134,5
Total input power (EN14511) <sup>(1)</sup> kW	5,5	7,1	8,5	11,1	11,4	13,1	14,9	16,6	20,3	23,4	26,4	29,6
COP (EN14511) <sup>(1)</sup>	W/W	4,23	4,18	4,34	4,16	4,35	4,42	4,29	4,51	4,34	4,21	4,55
Energy Class <sup>(2)</sup>		A++	A++	A++	A++	A++	A++	A++	A++	A++	A++	A++
SCOP <sup>(2)</sup>	kWh/kWh	3,83	3,86	3,92	3,91	3,98	4,19	4,09	4,00	4,05	4,01	3,86
η <sub>s,h</sub> <sup>(2)</sup>	%	150,2	151,3	153,8	153,2	156,2	164,5	160,6	156,9	158,8	157,4	151,5
Cooling capacity (EN14511) <sup>(3)</sup> kW	19,7	25,4	30,4	39,9	44,1	52,4	57,5	63,4	80,5	90,2	100,5	117,4
Total input power (EN14511) <sup>(3)</sup> kW	7,0	9,3	10,9	14,9	16,2	18,3	21,3	24,0	26,6	31,2	35,2	38,6
EER (EN14511) <sup>(3)</sup>	W/W	2,83	2,73	2,78	2,67	2,72	2,87	2,70	2,65	3,03	2,89	3,04
TER (EN14511) <sup>(4)</sup>	W/W	9,44	9,43	9,56	9,54	10,41	10,48	10,42	10,43	9,84	9,63	9,46
Sound power <sup>(5)</sup>	dB (A)	68	68	68	69	72	72	73	74	76	78	79
Sound pressure <sup>(6)</sup>	dB (A)	36	36	36	37	40	40	40	41	42	44	47
Power supply	V/Ph/Hz	400/3+N/50	400/3+N/50	400/3/50	400/3/50	400/3/50	400/3/50	400/3/50	400/3/50	400/3/50	400/3/50	400/3/50
Compressors / Circuits	n° / n°	2 / 1	2 / 1	2 / 1	2 / 1	2 / 1	2 / 1	2 / 1	2 / 1	2 / 1	2 / 1	2 / 1
Fans	n°	2	2	2	2	2	2	2	2	2	2	3
Refrigerant		R410A	R410A	R410A	R410A	R410A	R410A	R410A	R410A	R410A	R410A	R410A
Refrigerant charge	kg	10,0	10,0	10,0	10,0	14,5	19,0	19,0	19,0	27,0	27,0	36,0
Global warming potential (GWP)		2088	2088	2088	2088	2088	2088	2088	2088	2088	2088	2088
Equivalent CO <sub>2</sub> charge	t	20,88	20,88	20,88	20,88	30,27	39,67	39,67	39,67	56,37	56,37	75,16
Water tank volume	l	100	100	100	100	100	300	300	300	300	300	500

HA/XL/RV - P4S	1602	1802	2002	2302	2502	2504	3004	3204	3504	4004	4504	5004 *
Heating capacity (EN14511) <sup>(1)</sup> kW	148,2	162,5	176,9	204,1	232,2	221,2	265,0	287,3	317,0	349,0	389,3	439,8
Total input power (EN14511) <sup>(1)</sup> kW	33,8	39,3	43,9	48,1	53,8	54,0	62,6	69,7	78,3	85,5	97,8	109,1
COP (EN14511) <sup>(1)</sup>	W/W	4,39	4,13	4,03	4,24	4,32	4,10	4,23	4,12	4,05	3,98	4,03
Energy Class <sup>(2)</sup>		A++	A++	A+	A++	A++	A+	A+	A+	A+	A++	A+
SCOP <sup>(2)</sup>	kWh/kWh	3,92	3,86	3,76	4,00	3,98	3,74	3,79	3,78	3,82	3,88	3,81
η <sub>s,h</sub> <sup>(2)</sup>	%	153,7	151,3	147,3	156,8	156,3	146,5	148,6	148,2	149,8	152,0	150,3
Cooling capacity (EN14511) <sup>(3)</sup> kW	124,4	139,3	152,2	174,1	187,4	190,3	223,6	245,3	275,7	306,0	353,1	381,9
Total input power (EN14511) <sup>(3)</sup> kW	44,4	52,0	59,7	67,0	78,1	73,8	80,1	91,5	106,4	120,5	135,8	155,9
EER (EN14511) <sup>(3)</sup>	W/W	2,80	2,68	2,55	2,60	2,40	2,58	2,79	2,68	2,59	2,54	2,45
TER (EN14511) <sup>(4)</sup>	W/W	9,87	9,99	9,90	9,79	9,74	9,27	9,18	9,60	9,68	9,71	9,62
Sound power <sup>(5)</sup>	dB (A)	81	81	81	83	84	81	83	84	84	84	86
Sound pressure <sup>(6)</sup>	dB (A)	49	49	49	51	52	49	51	52	52	52	55

HE/XL/RV - P4S	1602	1802	2002	2302	2502	2504	3004	3204	3504	4004	4504	5004 *
Heating capacity (EN14511) <sup>(1)</sup> kW	147,7	162,2	175,5	202,8	230,8	220,5	264,9	287,2	317,0	348,5	396,4	441,7
Total input power (EN14511) <sup>(1)</sup> kW	33,0	38,6	43,4	47,6	52,9	53,0	60,9	68,2	77,1	84,6	97,5	108,0
COP (EN14511) <sup>(1)</sup>	W/W	4,48	4,20	4,04	4,26	4,36	4,16	4,35	4,21	4,11	4,12	4,14
Energy Class <sup>(2)</sup>		A++	A++	A++	A++	A++	A++	A++	A++	A++	A++	A++
SCOP <sup>(2)</sup>	kWh/kWh	4,06	4,01	3,85	4,10	4,06	3,84	3,97	3,92	3,96	3,97	3,91
η <sub>s,h</sub> <sup>(2)</sup>	%	159,5	157,4	151,1	161,0	159,3	150,4	155,9	153,8	155,5	155,9	153,5
Cooling capacity (EN14511) <sup>(3)</sup> kW	129,5	146,8	159,2	180,4	202,1	198,5	231,0	259,7	289,4	322,6	368,5	406,9
Total input power (EN14511) <sup>(3)</sup> kW	44,1	50,8	58,8	66,2	73,3	72,7	80,5	89,2	105,2	118,2	135,0	151,3
EER (EN14511) <sup>(3)</sup>	W/W	2,94	2,89	2,71	2,73	2,76	2,73	2,87	2,91	2,75	2,73	2,69
TER (EN14511) <sup>(4)</sup>	W/W	9,87	9,99	9,90	9,79	9,74	9,27	9,18	9,60	9,68	9,71	9,62
Sound power <sup>(5)</sup>	dB (A)	80	81	81	83	84	81	82	83	84	84	86
Sound pressure <sup>(6)</sup>	dB (A)	48	49	49	51	52	49	50	51	52	52	55
Power supply	V/Ph/Hz	400/3/50	400/3/50	400/3/50	400/3/50	400/3/50	400/3/50	400/3/50	400/3/50	400/3/50	400/3/50	400/3/50
Compressors / Circuits	n° / n°	2 / 1	2 / 1	2 / 1	2 / 1	2 / 1	4 / 2	4 / 2	4 / 2	4 / 2	4 / 2	4 / 2
Fans	n°	3	3	3	3	3	4	6	6	6	8	8
Refrigerant		R410A	R410A	R410A	R410A	R410A	R410A	R410A	R410A	R410A	R410A	R410A
Refrigerant charge	kg	36,0	36,0	45,0	45,0	60,0	60,0	72,0	72,0	90,0	90,0	100,0
Global warming potential (GWP)		2088	2088	2088	2088	2088	2088	2088	2088	2088	2088	2088
Equivalent CO <sub>2</sub> charge	t	75,16	75,16	93,96	93,96	125,28	125,28	150,33	150,33	150,33	187,92	208,80
Water tank volume	l	500	500	500	500	500	1000	1000	1000	1000	1000	1000

\* Units only available for the non-EU market

Performances are referred to the following conditions:

- (1) Heating: Ambient temperature 7°C DB, 6°C WB, water temperature 30/35°C.
- (2) Average conditions, low temperature, variable - Reg EU 811/2013
- (3) Cooling: ambient air temperature 35°C, evaporator water temperature in/out 12/7 °C.

(4) TER: Total Energy Ratio - cold circuit 12/7°C, hot circuit 30/35°C.

(5) Sound power level in accordance with ISO 3744.

(6) Sound pressure level at 10 mt from the unit in free field conditions in accordance with ISO 3744.

## Reversible heating/cooling version (RV)

HA/XL/RV - P4U	252	302	412	432	492	602	702	802	902	1002	1202	1402	
Heating capacity (EN14511) <sup>(1)</sup> kW	23,9	30,7	36,8	46,2	49,4	62,2	67,9	72,8	94,9	104,9	114,8	139,7	
Total input power (EN14511) <sup>(1)</sup> kW	5,8	7,4	8,8	11,2	11,7	13,5	15,2	16,8	21,0	24,1	27,2	30,7	
COP (EN14511) <sup>(1)</sup>	W/W	4,15	4,14	4,20	4,12	4,21	4,62	4,47	4,35	4,52	4,36	4,22	4,55
Energy Class <sup>(2)</sup>		A+	A+	A+	A+	A+	A++	A++	A++	A++	A++	A+	A++
SCOP <sup>(2)</sup>	kWh/kWh	3,45	3,65	3,68	3,65	3,77	4,11	4,06	3,99	3,96	3,94	3,80	4,03
η <sub>s,h</sub> <sup>(2)</sup>	%	134,9	142,8	144,0	143,0	147,9	161,5	159,4	156,7	155,2	154,7	148,8	158,2
Cooling capacity (EN14511) <sup>(3)</sup> kW	19,5	24,7	29,7	38,9	42,8	50,4	55,7	60,3	78,1	86,4	94,1	114,3	
Total input power (EN14511) <sup>(3)</sup> kW	7,2	9,7	11,2	15,4	16,7	19,1	22,0	25,1	26,7	31,5	36,8	39,0	
EER (EN14511) <sup>(3)</sup>	W/W	2,72	2,55	2,65	2,54	2,57	2,64	2,53	2,40	2,93	2,74	2,56	2,93
TER (EN14511) <sup>(4)</sup>	W/W	9,44	9,43	9,56	9,54	10,41	10,48	10,42	10,43	9,84	9,63	9,46	9,91
Sound power <sup>(5)</sup>	dB (A)	70	70	70	70	72	72	73	75	76	78	80	
Sound pressure <sup>(6)</sup>	dB (A)	38	38	38	38	40	40	41	43	44	46	48	
HE/XL/RV - P4U	252	302	412	432	492	602	702	802	902	1002	1202	1402	
Heating capacity (EN14511) <sup>(1)</sup> kW	23,9	30,7	36,9	46,3	49,7	62,0	67,9	72,8	94,7	104,6	113,8	139,4	
Total input power (EN14511) <sup>(1)</sup> kW	5,5	7,1	8,5	11,1	11,4	13,2	14,9	16,5	20,4	23,6	26,8	29,8	
COP (EN14511) <sup>(1)</sup>	W/W	4,39	4,29	4,34	4,16	4,35	4,71	4,55	4,40	4,64	4,44	4,25	4,68
Energy Class <sup>(2)</sup>		A+	A++	A++	A++	A++	A++	A++	A++	A++	A++	A++	A++
SCOP <sup>(2)</sup>	kWh/kWh	3,96	3,93	3,92	3,91	3,98	4,26	4,19	4,10	4,08	4,10	3,92	4,22
η <sub>s,h</sub> <sup>(2)</sup>	%	155,2	154,3	153,8	153,2	156,2	167,5	164,4	161,1	160,1	160,9	153,7	165,8
Cooling capacity (EN14511) <sup>(3)</sup> kW	19,7	25,4	30,4	39,9	44,1	52,4	57,5	63,4	80,5	90,2	100,5	117,4	
Total input power (EN14511) <sup>(3)</sup> kW	7,0	9,3	10,9	14,9	16,2	18,3	21,3	24,0	26,6	31,2	35,2	38,6	
EER (EN14511) <sup>(3)</sup>	W/W	2,83	2,73	2,78	2,67	2,72	2,87	2,70	2,65	3,03	2,89	2,86	3,04
TER (EN14511) <sup>(4)</sup>	W/W	9,44	9,43	9,56	9,54	10,41	10,48	10,42	10,43	9,84	9,63	9,46	9,91
Sound power <sup>(5)</sup>	dB (A)	68	68	68	69	72	72	73	74	76	78	79	
Sound pressure <sup>(6)</sup>	dB (A)	36	36	36	37	40	40	41	42	44	46	47	
Power supply	V/Ph/Hz	400/3+N/50	400/3+N/50	400/3/50	400/3/50	400/3/50	400/3/50	400/3/50	400/3/50	400/3/50	400/3/50	400/3/50	400/3/50
Compressors / Circuits	n° / n°	2 / 1	2 / 1	2 / 1	2 / 1	2 / 1	2 / 1	2 / 1	2 / 1	2 / 1	2 / 1	2 / 1	2 / 1
Fans	n°	2	2	2	2	2	2	2	2	2	2	2	3
Refrigerant		R410A	R410A	R410A	R410A	R410A	R410A	R410A	R410A	R410A	R410A	R410A	R410A
Refrigerant charge	kg	10,0	10,0	10,0	10,0	14,5	19,0	19,0	19,0	27,0	27,0	27,0	36,0
Global warming potential (GWP)		2088	2088	2088	2088	2088	2088	2088	2088	2088	2088	2088	2088
Equivalent CO <sub>2</sub> charge	t	20,88	20,88	20,88	20,88	30,27	39,67	39,67	39,67	56,37	56,37	56,37	75,16
Water tank volume	l	100	100	100	100	100	300	300	300	300	300	300	500

HA/XL/RV - P4U	1602	1802	2002	2302	2502	2504	3004	3204	3504	4004	4504	5004 *	
Heating capacity (EN14511) <sup>(1)</sup> kW	152,4	168,7	183,3	209,6	238,5	228,9	272,9	296,0	327,2	361,2	389,3	452,6	
Total input power (EN14511) <sup>(1)</sup> kW	34,0	38,3	43,0	48,3	53,8	55,1	64,0	69,8	78,5	86,9	97,8	111,0	
COP (EN14511) <sup>(1)</sup>	W/W	4,49	4,40	4,27	4,34	4,43	4,16	4,26	4,24	4,17	4,16	3,98	4,08
Energy Class <sup>(2)</sup>		A++	A++	A++	A++	A++	A+	A+	A++	A++	A++	A++	A++
SCOP <sup>(2)</sup>	kWh/kWh	4,00	4,02	3,94	4,08	4,10	3,76	3,80	3,90	3,92	3,89	3,85	3,85
η <sub>s,h</sub> <sup>(2)</sup>	%	157,1	157,9	154,4	160,0	160,9	147,2	149,1	152,9	153,6	152,4	151,1	150,8
Cooling capacity (EN14511) <sup>(3)</sup> kW	124,4	139,3	152,2	174,1	187,4	190,3	223,6	245,3	275,7	306,0	353,1	381,9	
Total input power (EN14511) <sup>(3)</sup> kW	44,4	52,0	59,7	67,0	78,1	73,8	80,1	91,5	106,4	120,5	135,8	155,9	
EER (EN14511) <sup>(3)</sup>	W/W	2,80	2,68	2,55	2,60	2,40	2,58	2,79	2,68	2,59	2,54	2,60	2,45
TER (EN14511) <sup>(4)</sup>	W/W	9,87	9,99	9,90	9,79	9,74	9,27	9,18	9,60	9,68	9,71	9,62	9,50
Sound power <sup>(5)</sup>	dB (A)	81	81	81	83	84	81	83	84	84	84	86	87
Sound pressure <sup>(6)</sup>	dB (A)	49	49	49	51	52	49	51	52	52	52	54	55
HE/XL/RV - P4U	1602	1802	2002	2302	2502	2504	3004	3204	3504	4004	4504	5004 *	
Heating capacity (EN14511) <sup>(1)</sup> kW	151,8	168,2	182,6	208,9	237,7	228,1	272,9	296,0	327,3	358,7	396,4	454,4	
Total input power (EN14511) <sup>(1)</sup> kW	33,2	37,6	42,4	47,8	53,1	54,3	62,3	68,4	77,4	86,1	97,5	110,1	
COP (EN14511) <sup>(1)</sup>	W/W	4,58	4,47	4,30	4,37	4,47	4,20	4,38	4,33	4,23	4,17	4,14	4,13
Energy Class <sup>(2)</sup>		A++	A++	A++	A++	A++	A++	A++	A++	A++	A++	A++	A++
SCOP <sup>(2)</sup>	kWh/kWh	4,15	4,16	4,03	4,17	4,18	3,85	3,98	4,04	4,06	3,99	3,99	3,96
η <sub>s,h</sub> <sup>(2)</sup>	%	163,0	163,4	158,2	163,9	164,0	151,1	156,3	158,5	159,2	156,4	156,6	155,3
Cooling capacity (EN14511) <sup>(3)</sup> kW	129,5	146,8	159,2	180,4	202,1	198,5	231,0	259,7	289,4	322,6	368,5	406,9	
Total input power (EN14511) <sup>(3)</sup> kW	44,1	50,8	58,8	66,2	73,3	72,7	80,5	89,2	105,2	118,2	135,0	151,3	
EER (EN14511) <sup>(3)</sup>	W/W	2,94	2,89	2,71	2,73	2,76	2,73	2,87	2,91	2,75	2,73	2,73	2,69
TER (EN14511) <sup>(4)</sup>	W/W	9,87	9,99	9,90	9,79	9,74	9,27	9,18	9,60	9,68	9,71	9,62	9,50
Sound power <sup>(5)</sup>	dB (A)	80	81	81	83	84	81	82	83	84	84	86	87
Sound pressure <sup>(6)</sup>	dB (A)	48	49	49	51	52	49	50	51	52	52	54	55
Power supply	V/Ph/Hz	400/3/50	400/3/50	400/3/50	400/3/50	400/3/50	400/3/50	400/3/50	400/3/50	400/3/50	400/3/50	400/3/50	400/3/50
Compressors / Circuits	n° / n°	2 / 1	2 / 1	2 / 1	2 / 1	2 / 1	4 / 2	4 / 2	4 / 2	4 / 2	4 / 2	4 / 2	4 / 2
Fans	n°	3	3	3	3	3	4	6	6	6	6	8	8
Refrigerant		R410A	R410A	R410A	R410A	R410A	R410A	R410A	R410A	R410A	R410A	R410A	R410A
Refrigerant charge	kg	36,0	36,0	45,0	45,0	60,0	60,0	72,0	72,0	90,0	90,0	100,0	
Global warming potential (GWP)		2088	2088	2088	2088	2088	2088	2088	2088	2088	2088	2088	2088
Equivalent CO <sub>2</sub> charge	t	75,16	75,16	93,96	93,96	125,28	125,28	150,33	150,33	187,92	187,92	208,80	
Water tank volume	l	500	500	500	500	500	1000	1000	1000	1000	1000	1000	1000

\* Units only available for the non-EU market

Performances are referred to the following conditions:

(1) Heating: Ambient temperature 7°C DB, 6°C WB, water temperature 30/35°C.

(2) Average conditions, low temperature, variable - Reg EU 811/2013

(3) Cooling: ambient air temperature 35°C, evaporator water temperature in/out 12/7 °C.

(4) TER: Total Energy Ratio - cold circuit 12/7°C, hot circuit 30/35°C.

(5) Sound power level in accordance with ISO 3744.

(6) Sound pressure level at 10 mt from the unit in free field conditions in accordance with ISO 3744.

## COMPONENTS

### FRAME

All units are made from hot-galvanised sheet steel, painted with polyurethane powder enamel and stoved at 180°C to provide maximum protection against corrosion. The frame is self-supporting with removable panels. All screws and rivets used are made from stainless steel. The standard colour of the units is RAL9018.

### REFRIGERANT CIRCUIT

The refrigerant utilised is R410A. The refrigerant circuit is assembled using internationally recognised brand name components with all brazing and welding being performed in accordance with ISO 97/23. The refrigerant circuit includes: sight glass, filter drier, two thermal expansion valves (one for cooling mode, one for heating mode) with external equalizer, 4 way reversing valve, check valves, liquid receiver, Schrader valves for maintenance and control, pressure safety device (for compliance with PED regulations).

### COMPRESSORS

The compressors used are a high performance scroll type that incorporates a special scroll design which enhances the efficiency of the refrigerant cycle when the source temperature is low. In all units the compressors are connected in tandem.

The compressors are all supplied with a crankcase heater and thermal overload protection by a klixon embedded in the motor winding. They are mounted in a separate enclosure in order to be separated from the air stream thus enabling them to be maintained even if the unit is operating. Access to this enclosure is by the front panel of the unit. The crankcase heater is always powered when the compressor is in stand-by.

### SOURCE HEAT EXCHANGER

The source heat exchanger is made from copper pipes and aluminium fins. Dimensioning of the copper pipes and the aluminium wings is optimized in order to obtain excellent performance. The tubes are mechanically expanded into the fins in order to maximise heat transfer. Furthermore, the design guarantees a low air side pressure drop thus enabling the use of low rotation speed (and hence low noise) fans. All heat exchangers are supplied standard with fins hydrophilic coating.

### USER HEAT EXCHANGERS

The user heat exchanger is a braze welded, plate type heat exchanger, manufactured from AISI 316 stainless steel.

The use of this type of exchanger results in a massive reduction of the refrigerant charge of the unit compared to a traditional shell-in-tube type. A further advantage is a reduction in the overall dimensions of the unit.

The exchangers are factory insulated with flexible close cell material and can be fitted with an antifreeze heater (accessory). Each exchanger is fitted with a temperature sensor on the discharge water side for antifreeze protection.

### FANS

The fans are direct drive axial type with aluminium aerofoil blades, are statically and dynamically balanced and are supplied complete with a safety fan guard complying with the requirements of EN 60335.

They are fixed to the unit frame via rubber anti-vibration mountings. The electric motors, in LS versions are 6 poles type rotating at approximately 900 rpm. In the XL versions the fans are 8 poles

type (approx 600 rpm). The motors are fitted with integrated thermal overload protection and have a moisture protection rating of IP 54.

### MICROPROCESSORS

All units are supplied as standard complete with control panel. The microprocessor controls the following functions: control of the water temperature, antifreeze protection, compressor timing, compressor automatic starting sequence (For multiple compressors), alarm reset.

The control panel is supplied with display showing all operational icons. The microprocessor is set for automatic defrost (when operating in severe ambient conditions) and for summer/ winter change over (only for RV versions).

The control also manages the anti-legionella program, the integration with other heating sources (electric heaters, boilers, solar panels etc), the operation of a three port modulating valve (for diverting to DHW or heating) and both the heating circuit pump and the domestic hot water circuit pump. If required (available as an option), the microprocessor can be configured in order for it to connect to a site BMS system thus enabling remote control and management.

### ELECTRIC ENCLOSURE

The enclosure is manufactured in order to comply with the requirements of the electromagnetic compatibility standards CEE EN60204. Access to electrical cabinet in quick and easy thanks to hinged panels. The following components are supplied as standard on all units: main switch, a sequence relay that disables the power supply in the event that the phase sequence is incorrect (scroll compressors can be damaged if they rotate in the wrong direction), thermal overloads (protection of pumps and fans), compressor fuses, control circuit automatic breakers, compressor contactors, fan contactors and pump contactors. The terminal board has volt free contacts for remote ON-OFF, Summer/ winter change over (heat pumps only) and general alarm.

### CONTROL AND PROTECTION DEVICES

All units are supplied with the following controls and protections: user water return temperature sensor, antifreeze protection temperature sensor installed on users water output, domestic hot water supply and return temperature sensors, high pressure manual reset, low pressure automatic reset, compressor thermal protection, air fan, thermal protection, pressure transducer (used to optimize the defrost cycle and to adjust the fan speed depending on ambient conditions), flow switch.

All units in HA and HE versions are also fitted with a temperature probe sensor with "Energy Saving" function, supplied in a separate plastic box, which can be used to stop the pump use during periods of stand-by, when the water temperature reaches the set point. Doing this the power consumption of the unit is strongly reduced. The probe sensor must be positioned in the hydraulic compensator present at the screening technique.

The domestic hot water circuit (only versions P2S) is already equipped with this probe, but it must be installed in the user circuit.

## VERSIONS

### P4U version

The P4U units use 4 hydraulic connections and are used in modern 4-pipe systems. In these systems, cold and hot water is always available (in every period of the year) and present in the specific hydraulic circuit.

These systems allow the simultaneous production of cold water and hot water using 4 hydraulic connections, 2 connections are related to the hot water circuit, 2 connections are related to the cold water circuit.

The plant thus conceived is able to heat and, at the same time, if required, to cool with very high energy efficiencies. In this configuration, however, the units are also able to produce hot or cold water separately at any time of the year.

The units are supplied with 2 heat exchangers, one dedicated to the production of cold water and one dedicated to the production of hot water.

The operating modes are:

**1. User water heating:** The unit behaves like a normal air/water heat pump in heating mode, using the finned heat exchanger as the source and the A plate heat exchanger as user.

**2. User water cooling:** The unit behaves like a normal air / water chiller in cooling mode, using the finned exchanger as the source and the B plate heat exchanger as user.

**3. Simultaneous user Cooling + heating:** The unit behaves like a water / water heat pump, using the plate heat exchanger B as the cold user and the plate heat exchanger A as hot user. This version is not able to produce domestic hot water.

### P4S Version

The P4S units have been designed to meet the needs of 2 + 2 pipe systems (2 user side pipes, 2 domestic hot water pipes) throughout the year. The units are supplied with 2 exchangers, one dedicated to the production of the user cold and hot water and one dedicated to the production of domestic hot water only (D.H.W.). The production of domestic hot water always has priority. In winter mode the activation of D.H.W. production temporarily stops the production of the user hot water, which is restored when the D.H.W. accumulation reaches the temperature set. In summer mode the unit will switch to cooling (by activating the reverse cycle valve installed in the refrigerant circuit) and any request for domestic hot water will allow, at the same time, the production of cold water. In this operating mode, the system can simultaneously produce cold water and domestic hot water. Domestic hot water, in summer mode, is produced by heat recovery and therefore free of charge. When the temperature measured by the D.H.W. sensor reaches the set, the D.H.W. water pump is stopped and normal operation is restored in cooling mode.

The operating modes are:

## P4U VERSION

User water heating

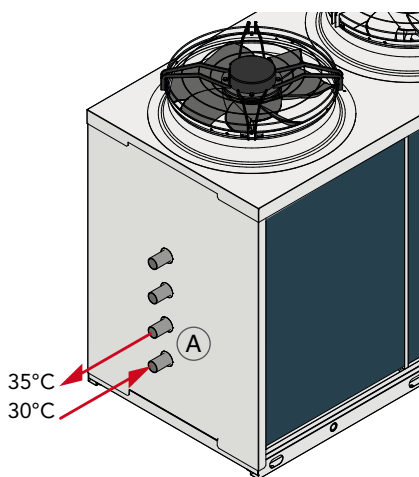

User water cooling

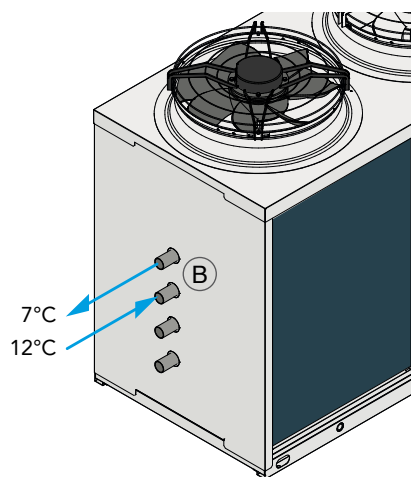

Simultaneous user Cooling + heating

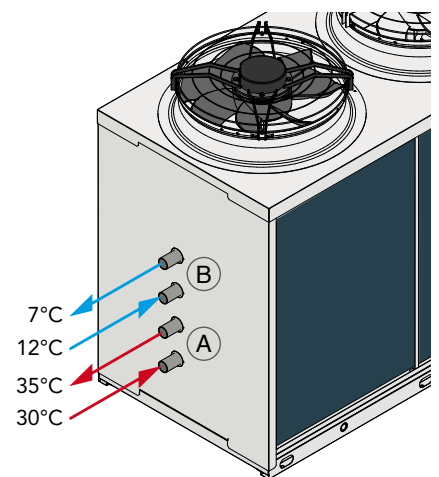

**1. User water heating:** The unit behaves like a normal air/water heat pump in heating mode, using the finned heat exchanger as the source and the A plate heat exchanger as user.

**2. User water cooling:** The unit behaves like a normal air/water chiller in cooling mode, using the finned heat exchanger as the source and the A plate heat exchanger as user.

**3. Domestic hot water production (D.H.W.):** The unit behaves like a normal air / water heat pump in heating mode, using the finned heat exchanger as the source and as a user the plate heat exchanger B (a special D.H.W. heat exchanger that works with a higher set point).

**4. User water cooling + D.H.W. production:** The unit behaves like a water / water heat pump, using the plate heat exchanger A as the cold user and the plate heat exchanger B as D.H.W. production).

**SA Version**

Standard efficiency version, according to current standard. Unit equipped with AC fans.

**SE Version**

Standard efficiency version, according to current standard. Unit equipped with EC fans.

**HA Version**

High efficiency version, according to current standard. Unit equipped with AC fans.

**HE Version**

High efficiency version, according to current standard. Unit equipped with EC fans.

**Version LS**

This version includes the complete acoustic insulation of the unit with compressor jackets and insulating material made with high density media and the interposition of heavy bitumen layer.

**P4S VERSION**

User water heating

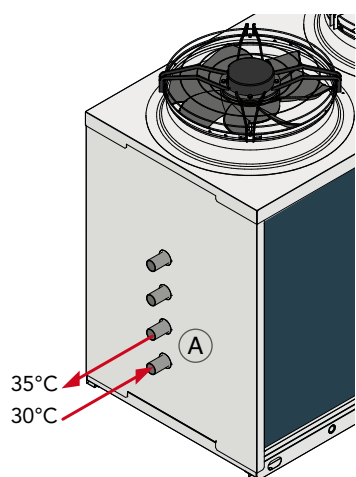

User water cooling

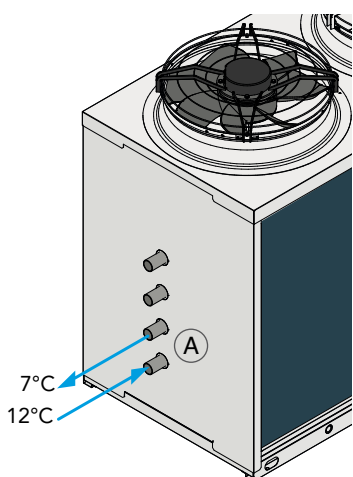

Domestic hot water production (D.H.W.)

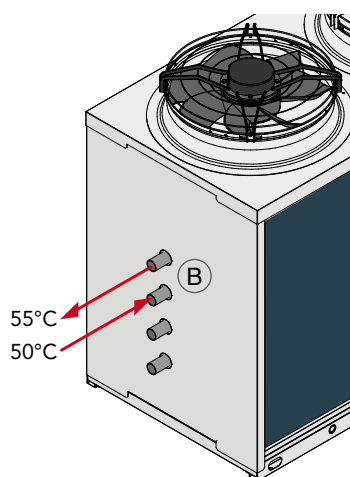

User water cooling + D.H.W. production

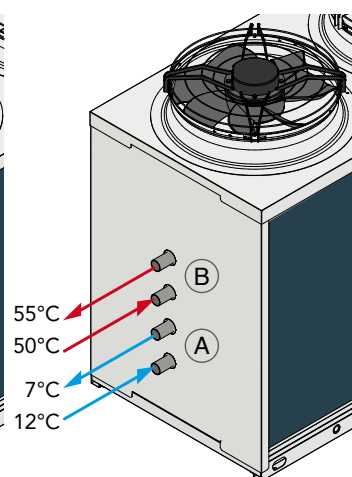

### XL Super low noise version

All units in XL super low noise version are supplied, as standard, with the latest 'Floating Frame' technology that completely isolates the compressors from the main casing, thereby eliminating vibration and noise from this source. The 'Floating Frame' is a special vibration and acoustic damping system that consists of a base plate and acoustic enclosure that houses the compressors. The base plate is separated from the supporting frame of the unit by soft steel springs that have a high damping power. Within the enclosure, the compressors are mounted on rubber shock absorbers on the floating base plate. The enclosure is manufactured from galvanized steel sandwich panels that have a micro-perforated inner skin and a core of 30 mm thick, high density (25 kg/m<sup>3</sup>). The entire arrangement provides a double damping system and acoustic attenuation. The compressor refrigerant pipes are connected to the refrigerant circuit through "anaconda" flexible connections. Flexible connections are also used on the water pipework within the unit. The combination of these systems results in an overall noise reduction in the region of 6-8 dB(A).

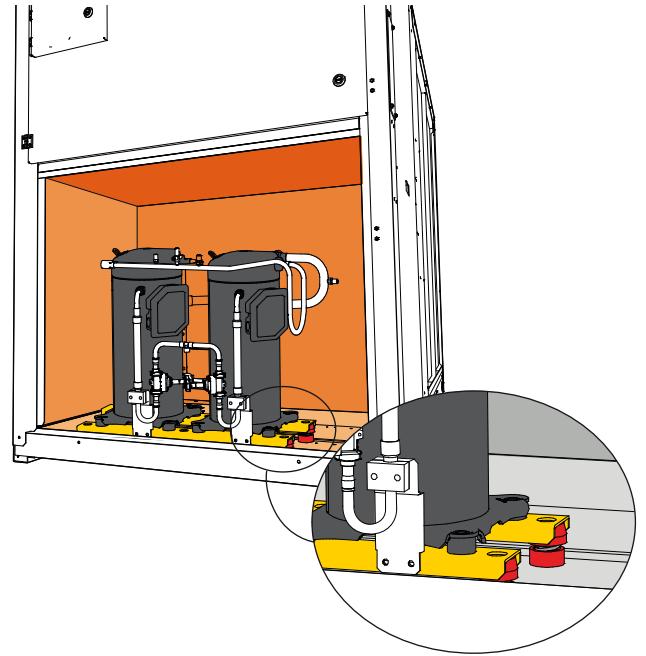

## OPERATION LIMITS

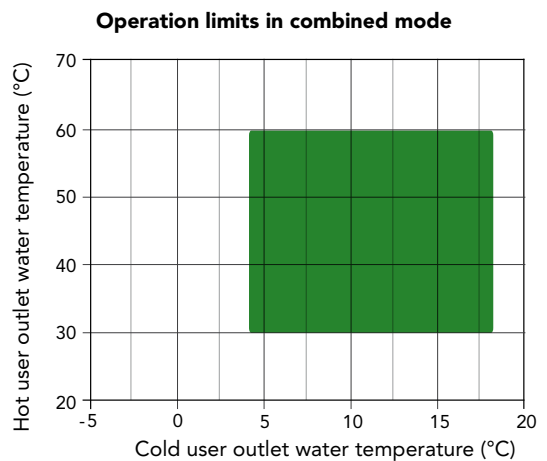
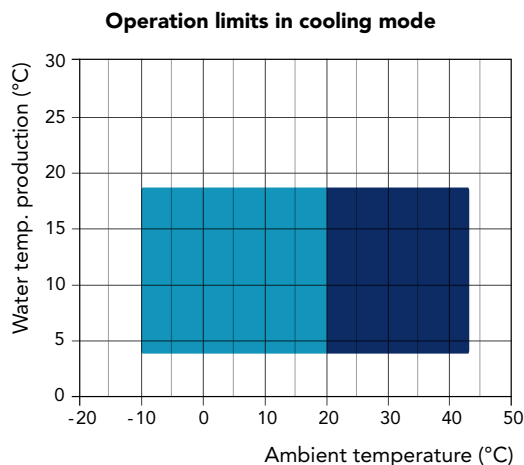
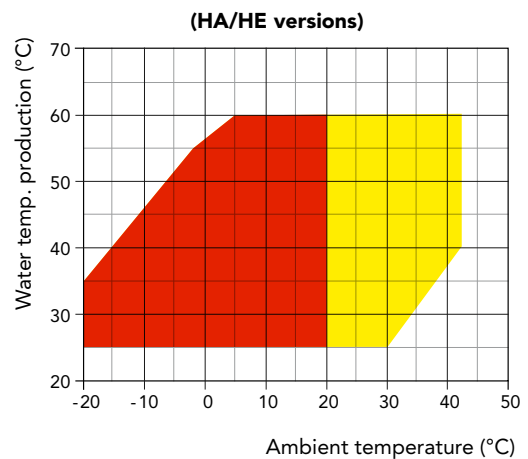
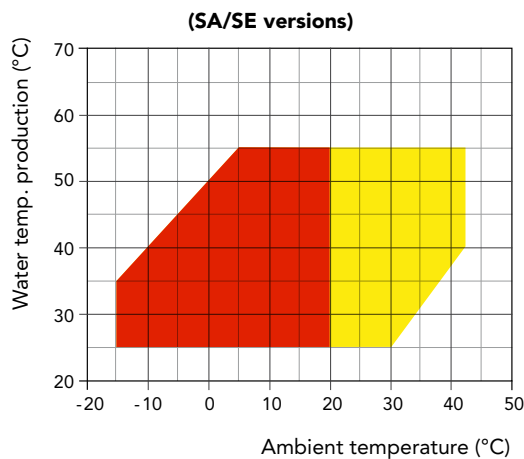

- Heating mode
- Heating mode with head pressure control (DCCF)
- Cooling with head pressure control (DCCF)

- Cooling mode
- Combined mode

# ACCESSORIES

LHA SA-SE/HH-RV	LHA HA-HE/HH-RV	P4S/P4U	242 252	292 302	402	412	432	492	592	602	702	802
Flow switch			●	●	●	●	●	●	●	●	●	●
"Floating frame" Technology - LS Version			-	-	-	-	-	-	-	-	-	-
"Floating frame" Technology - XL Version			●	●	●	●	●	●	●	●	●	●
E.C. fans - SA versions		<b>VECE</b>	-	-	-	-	-	-	-	-	-	-
E.C. fans - SE versions		<b>VECE</b>	●	●	●	●	●	●	●	●	●	●
E.C. fans - HA versions		<b>VECE</b>	-	-	-	-	-	-	-	-	-	-
E.C. fans - HE versions		<b>VECE</b>	●	●	●	●	●	●	●	●	●	●
Condensate discharge drip tray with antifreeze heater		<b>BRCA</b>	○	○	○	○	○	○	○	○	○	○
Fans regulation by phase cut		<b>DCCF</b>	●	●	●	●	●	●	●	●	●	●
Antifreeze kit for 4 pipe units		<b>RAEV4</b>	○	○	○	○	○	○	○	○	○	○
Electronic soft starter		<b>DSSE</b>	○	○	○	○	○	○	○	○	○	○
Serial interface card RS485		<b>INSE</b>	●	●	●	●	●	●	●	●	●	●
Rubber anti-vibration mountings		<b>KAVG</b>	○	○	○	○	○	○	○	○	○	○
Remote control panel		<b>PCRL</b>	○	○	○	○	○	○	○	○	○	○
Electronic expansion valve		<b>VTEE</b>	○	○	○	○	○	○	○	○	○	○
Cascade control system via RS485		<b>SGRS</b>	○	○	○	○	○	○	○	○	○	○
Hydraulic kit with one pump with tank		<b>A1ZZU</b>	○	○	○	○	○	○	○	○	○	○
Hydraulic kit with two pumps with tank		<b>A2ZZU</b>	○	○	○	○	○	○	○	○	○	○
Hydraulic kit with one pump without tank		<b>A1NTU</b>	○	○	○	○	○	○	○	○	○	○
Hydraulic kit with two pumps without tank		<b>A2NTU</b>	○	○	○	○	○	○	○	○	○	○
Hydraulic kit with 1 pump - recovery circuit		<b>A1NTR</b>	○	○	○	○	○	○	○	○	○	○
Hydraulic kit with 2 pumps - recovery circuit		<b>A2NTR</b>	○	○	○	○	○	○	○	○	○	○

● Standard ○ Optional - Not available

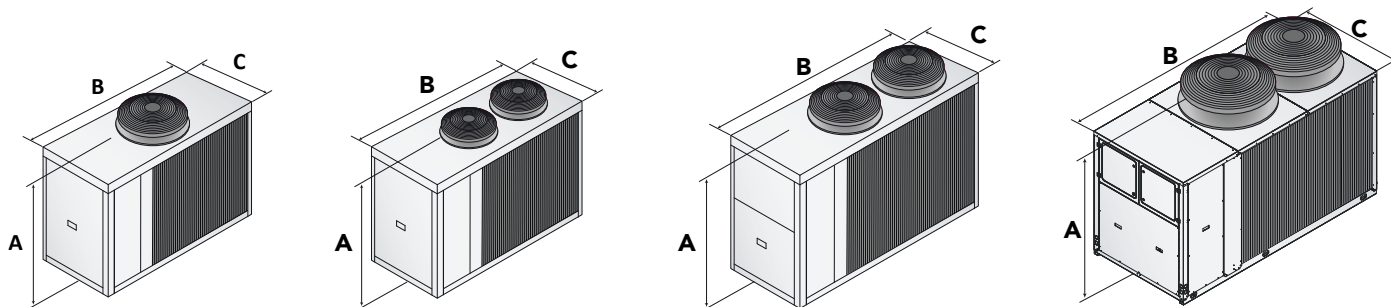

**SA/SE 242 - 292**  
**HA/HE LS 242 - 292**

**SA/SE 402**  
**HA/HE XL 252 - 302**

**SA/SE 432 - 492 - 592**  
**HA/HE-LS/XL 412 - 432 - 492**

**SA/SE 702 - 802 - 902**  
**HA/HE-LS/XL 602 - 702 - 802 - 902 - 1002 - 1202**

		242/252	292/302	402	412	432	492	592	602	702	802
A (mm)	<b>SA-SE/LS</b>	1500	1500	1500	--	1690	1690	1690	--	1880	1880
B (mm)	<b>SA-SE/LS</b>	1915	1915	1915	--	2400	2400	2400	--	2905	2905
C (mm)	<b>SA-SE/LS</b>	875	875	875	--	1150	1150	1150	--	1145	1150
kg	<b>SA-SE/LS</b>	550	550	560	--	670	700	760	--	880	890
A (mm)	<b>HA-HE/LS</b>	1500	1500	--	1690	1690	1690	--	1880	1890	1880
B (mm)	<b>HA-HE/LS</b>	1915	1915	--	2400	2400	2400	--	2905	2905	2905
C (mm)	<b>HA-HE/LS</b>	875	875	--	1150	1150	1150	--	1150	1150	1150
kg	<b>HA-HE/LS</b>	560	560	--	670	690	720	--	1060	1060	1070
A (mm)	<b>HA-HE/XL</b>	1500	1500	--	1690	1690	1690	--	1880	1880	1880
B (mm)	<b>HA-HE/XL</b>	1915	1915	--	2400	2400	2400	--	2905	2905	2905
C (mm)	<b>HA-HE/XL</b>	875	875	--	1150	1150	1150	--	1150	1150	1150
kg	<b>HA-HE/XL</b>	570	570	--	680	710	740	--	1080	1080	1090

LHA SA-SE/HH-RV LHA HA-HE/HH-RV	P4S/P4U	902	1002	1202	1402	1602	1802	2002	2302
Flow switch		●	●	●	●	●	●	●	●
"Floating frame" Technology - LS Version		-	-	-	-	-	-	-	-
"Floating frame" Technology - XL Version		●	●	●	●	●	●	●	●
E.C. fans - SA versions	VECE	-	-	-	-	-	-	-	-
E.C. fans - SE versions	VECE	●	●	●	●	●	●	●	●
E.C. fans - HA versions	VECE	-	-	-	-	-	-	-	-
E.C. fans - HE versions	VECE	●	●	●	●	●	●	●	●
Condensate discharge drip tray with antifreeze heater	BRCA	○	○	○	○	○	○	○	○
Fans regulation by phase cut	DCCF	●	●	●	●	●	●	●	●
Antifreeze kit for 4 pipe units	RAEV4	○	○	○	○	○	○	○	○
Electronic soft starter	DSSE	○	○	○	○	○	○	○	○
Serial interface card RS485	INSE	●	●	●	●	●	●	●	●
Rubber anti-vibration mountings	KAVG	○	○	○	○	○	○	○	○
Remote control panel	PCRL	○	○	○	○	○	○	○	○
Electronic expansion valve	VTEE	○	○	○	○	○	○	○	○
Cascade control system via RS485	SGRS	○	○	○	○	○	○	○	○
Hydraulic kit with one pump with tank	A1ZZU	○	○	○	○	○	○	○	○
Hydraulic kit with two pumps with tank	A2ZZU	○	○	○	○	○	○	○	○
Hydraulic kit with one pump without tank	A1NTU	○	○	○	○	○	○	○	○
Hydraulic kit with two pumps without tank	A2NTU	○	○	○	○	○	○	○	○
Hydraulic kit with 1 pump - recovery circuit	A1NTR	○	○	○	○	○	○	○	○
Hydraulic kit with 2 pumps - recovery circuit	A2NTR	○	○	○	○	○	○	○	○

● Standard ○ Optional - Not available

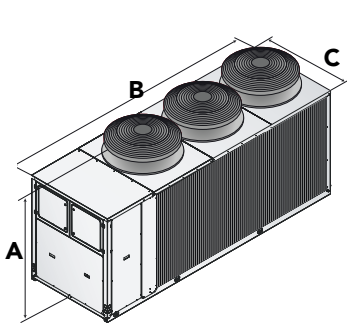

SA/SE 1002 - 1202 - 1402 - 1602  
HA/HE-LS/XL 1402 - 1602 - 1802 - 2002

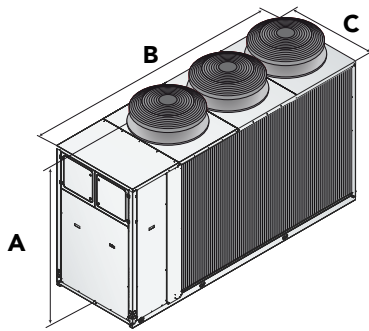

SA/SE 1802 - 2002  
HA/HE-LS/XL 2302 - 2502

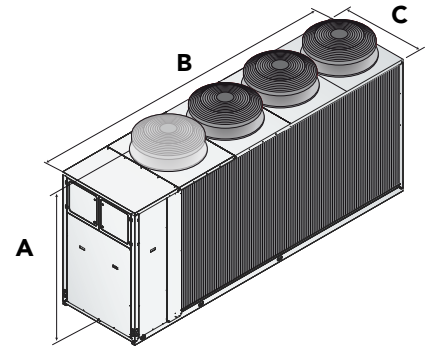

SA/SE 2302 - 2502

		902	1002	1202	1402	1602	1802	2002	2302
A (mm)	SA-SE/LS	1880	1880	1880	1880	1880	2270	2270	2310
B (mm)	SA-SE/LS	2905	3905	3905	3905	3905	3905	3905	4505
C (mm)	SA-SE/LS	1150	1150	1150	1150	1150	1150	1150	1150
kg	SA-SE/LS	910	1190	1270	1320	1360	1690	1710	1990
A (mm)	HA-HE/LS	1880	1880	1880	1880	1880	1880	1880	2280
B (mm)	HA-HE/LS	2905	2905	2905	3905	3905	3905	3905	3905
C (mm)	HA-HE/LS	1150	1150	1150	1150	1150	1150	1150	1150
kg	HA-HE/LS	1120	1160	1240	1560	1580	1600	1620	1790
A (mm)	HA-HE/XL	1880	1880	1880	1880	1880	1880	1880	2280
B (mm)	HA-HE/XL	2905	2905	2905	3905	3905	3905	3905	3905
C (mm)	HA-HE/XL	1150	1150	1150	1150	1150	1150	1150	1150
kg	HA-HE/XL	1140	1180	1260	1590	1610	1630	1650	1820

LHA SA-SE/HH-RV	LHA HA-HE/HH-RV	P4S/P4U	2502	2504	3004	3204	3504	4004	4504	5004
Flow switch			●	●	●	●	●	●	●	●
"Floating frame" Technology - LS Version			-	-	-	-	-	-	-	-
"Floating frame" Technology - XL Version			●	●	●	●	●	●	●	●
E.C. fans - SA versions	<b>VECE</b>		-	-	-	-	-	-	-	-
E.C. fans - SE versions	<b>VECE</b>		●	●	●	●	●	●	●	●
E.C. fans - HA versions	<b>VECE</b>		-	-	-	-	-	-	-	-
E.C. fans - HE versions	<b>VECE</b>		●	●	●	●	●	●	●	●
Condensate discharge drip tray with antifreeze heater	<b>BRCA</b>		○	○	○	○	○	○	○	○
Fans regulation by phase cut	<b>DCCF</b>		●	●	●	●	●	●	●	●
Antifreeze kit for 4 pipe units	<b>RAEV4</b>		○	○	○	○	○	○	○	○
Electronic soft starter	<b>DSSE</b>		○	○	○	○	○	○	○	○
Serial interface card RS485	<b>INSE</b>		●	●	●	●	●	●	●	●
Rubber anti-vibration mountings	<b>KAVG</b>		○	○	○	○	○	○	○	○
Remote control panel	<b>PCRL</b>		○	○	○	○	○	○	○	○
Electronic expansion valve	<b>VTEE</b>		○	○	○	○	○	○	○	○
Cascade control system via RS485	<b>SGRS</b>		○	○	○	○	○	○	○	○
Hydraulic kit with one pump with tank	<b>A1ZZU</b>		○	○	○	○	○	○	○	○
Hydraulic kit with two pumps with tank	<b>A2ZZU</b>		○	○	○	○	○	○	○	○
Hydraulic kit with one pump without tank	<b>A1NTU</b>		○	○	○	○	○	○	○	○
Hydraulic kit with two pumps without tank	<b>A2NTU</b>		○	○	○	○	○	○	○	○
Hydraulic kit with 1 pump - recovery circuit	<b>A1NTR</b>		○	○	○	○	○	○	○	○
Hydraulic kit with 2 pumps - recovery circuit	<b>A2NTR</b>		○	○	○	○	○	○	○	○

● Standard ○ Optional - Not available

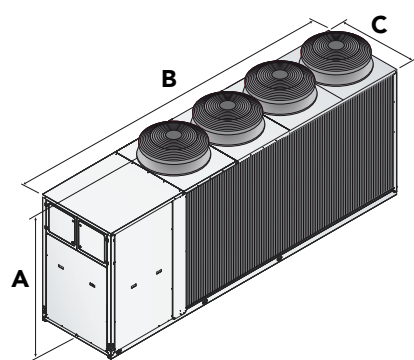

**SA/SE 2504 - 3004 - 3204**

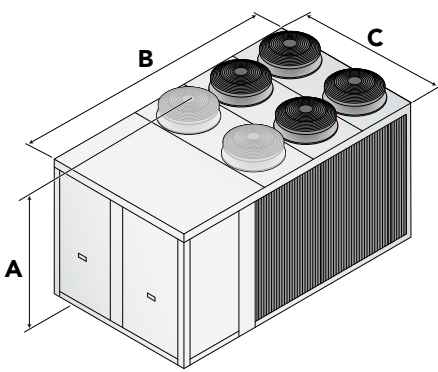

**SA/SE 3504 - 4004  
HA/HE-LS/XL 2504 - 3004 - 3204 - 3504**

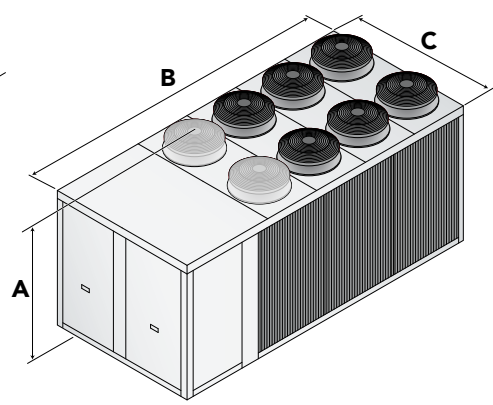

**SA/SE 4504 - 5004  
HA/HE-LS/XL 4004 - 4504 - 5004**

		2502	2504	3004	3204	3504	4004	4504	5004
A (mm)	<b>SA-SE/LS</b>	2310	2310	2310	2310	2350	2350	2380	2380
B (mm)	<b>SA-SE/LS</b>	4505	5300	5300	5300	4205	4205	4810	4810
C (mm)	<b>SA-SE/LS</b>	1150	1150	1150	1150	2210	2210	2210	2210
kg	<b>SA-SE/LS</b>	2040	2500	2540	2620	3220	3270	3600	3700
A (mm)	<b>HA-HE/LS</b>	2280	2350	2350	2350	2350	2380	2380	2380
B (mm)	<b>HA-HE/LS</b>	3905	4205	4205	4205	4205	4805	4810	4810
C (mm)	<b>HA-HE/LS</b>	1150	2210	2210	2210	2210	2210	2210	2210
kg	<b>HA-HE/LS</b>	1820	3170	3220	3270	3320	3660	3720	3780
A (mm)	<b>HA-HE/XL</b>	2280	2350	2350	2350	2350	2380	2380	2380
B (mm)	<b>HA-HE/XL</b>	3905	4205	4205	4205	4205	4805	4810	4810
C (mm)	<b>HA-HE/XL</b>	1150	2210	2210	2210	2210	2210	2210	2210
kg	<b>HA-HE/XL</b>	1850	3220	3270	3320	3370	3710	3770	3830

# LHE/P4

**HIGH EFFICIENCY AIR TO WATER MULTIPURPOSE UNIT AND 4 PIPE HEAT PUMPS**  
EQUIPPED WITH SCROLL COMPRESSOR AND AXIAL FANS WITH LOW GWP REFRIGERANT

Heating power from 45 kW to 454 kW

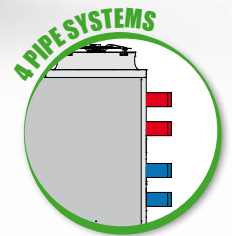
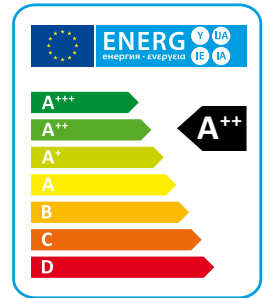

LHE high-efficiency air/water heat pumps are particularly suitable for applications where maximum efficiency in heating mode and a low noise level are required. The units are specifically designed to provide the best efficiency in heating mode; they can operate at outside temperatures down to -20°C and produce water up to a temperature of 60°C.

All sizes are supplied with reverse cycle valve used for winter defrost; the RV versions are also able to produce cold water in summer period (not available for HH versions).

## VERSIONS

- RV** Reversible heating/cooling.
- HA** High efficiency, AC fans.
- HE** High efficiency, EC fans.
- LS** Low noise.
- XL** Super low noise.
- P4U** 4 pipe systems heating/cooling.
- P4S** 2+2 pipe systems with D.H.W. production.

# TECHNICAL DATA

Reversible heating/cooling version (RV)

HA/LS/RV P4U		452	512	682	752	912	1102	1152	1352	1502	1612
Heating capacity (EN14511) <sup>(1)</sup>	kW	45,6	51,8	69,0	75,0	92,0	104,0	115,0	136,0	152,0	163,0
Total input power (EN14511) <sup>(1)</sup>	kW	11,2	12,5	15,6	17,6	21,7	24,5	27,0	32,1	36,6	38,8
COP (EN14511) <sup>(1)</sup>	W/W	4,07	4,14	4,42	4,26	4,24	4,24	4,26	4,24	4,15	4,20
Energy Class <sup>(2)</sup>		A+	A++	A++	A++	A+	A++	A++	A+	A+	A++
SCOP <sup>(2)</sup>	kWh/kWh	3,80	3,90	4,20	4,10	3,70	4,00	4,00	3,80	3,80	3,90
η <sub>s,h</sub> <sup>(2)</sup>	%	149	153	165	161	145	157	157	149	149	153
Cooling capacity (EN14511) <sup>(3)</sup>	kW	37,7	43,2	57,1	61,0	76,7	86,9	96,0	112,0	125,0	136,0
Total input power (EN14511) <sup>(3)</sup>	kW	14,0	16,4	21,3	24,6	26,5	30,3	35,0	38,3	44,3	48,5
EER (EN14511) <sup>(3)</sup>	W/W	2,69	2,63	2,68	2,48	2,89	2,87	2,74	2,92	2,82	2,80
TER (EN14511) <sup>(4)</sup>	W/W	9,61	9,84	10,2	9,82	10,1	9,91	10,1	9,86	9,57	9,80
Sound power <sup>(5)</sup>	dB (A)	77	76	77	78	82	83	85	86	87	87
Sound pressure <sup>(6)</sup>	dB (A)	46	44	45	46	50	51	53	54	55	55
<b>HE/LS/RV P4U</b>		<b>452</b>	<b>512</b>	<b>682</b>	<b>752</b>	<b>912</b>	<b>1102</b>	<b>1152</b>	<b>1352</b>	<b>1502</b>	<b>1612</b>
Heating capacity (EN14511) <sup>(1)</sup>	kW	45,2	51,8	69,2	75,4	91,6	103,0	114,0	135,0	151,0	163,0
Total input power (EN14511) <sup>(1)</sup>	kW	10,7	12,5	15,6	17,6	20,5	23,5	25,9	30,2	34,8	37,1
COP (EN14511) <sup>(1)</sup>	W/W	4,22	4,14	4,44	4,28	4,47	4,38	4,40	4,47	4,34	4,39
Energy Class <sup>(2)</sup>		A++	A++	A++	A++	A++	A++	A++	A++	A++	A++
SCOP <sup>(2)</sup>	kWh/kWh	4,10	4,00	4,20	4,30	4,10	4,30	4,30	4,20	4,20	4,10
η <sub>s,h</sub> <sup>(2)</sup>	%	161	157	165	169	161	169	169	165	165	161
Cooling capacity (EN14511) <sup>(3)</sup>	kW	36,9	43,2	57,6	61,5	76,5	85,5	95,0	112,0	124,0	134,0
Total input power (EN14511) <sup>(3)</sup>	kW	14,1	16,5	21,2	24,5	25,8	30,3	34,6	37,3	43,6	48,1
EER (EN14511) <sup>(3)</sup>	W/W	2,62	2,62	2,72	2,51	2,97	2,82	2,75	3,00	2,84	2,79
TER (EN14511) <sup>(4)</sup>	W/W	9,61	9,84	10,2	9,82	10,1	9,91	10,1	9,86	9,57	9,80
Sound power <sup>(5)</sup>	dB (A)	78	79	81	82	86	87	88	89	89	90
Sound pressure <sup>(6)</sup>	dB (A)	46	47	49	50	54	55	56	57	56	57
Power supply	V/Ph/Hz	400/3/50	400/3/50	400/3/50	400/3/50	400/3/50	400/3/50	400/3/50	400/3/50	400/3/50	400/3/50
Compressors / Circuits	n° / n°	2 / 1	2 / 1	2 / 1	2 / 1	2 / 1	2 / 1	2 / 1	2 / 1	2 / 1	2 / 1
Fans	n°	2	2	2	2	2	2	2	3	3	3
Refrigerant		R454B	R454B	R454B	R454B	R454B	R454B	R454B	R454B	R454B	R454B
Refrigerant charge	kg	11	11	17	17	25	25	25	36	36	36
Global warming potential (GWP)		466	466	466	466	466	466	466	466	466	466
Equivalent CO <sub>2</sub> charge	t	5,1	5,1	7,9	7,9	11,6	11,6	11,6	16,8	16,8	16,8
Water tank volume	l	140	140	300	300	300	300	300	500	500	500
<b>HA/LS/RV P4U</b>		<b>1792</b>	<b>2012</b>	<b>2304</b>	<b>2312</b>	<b>2654</b>	<b>2954</b>	<b>3214</b>	<b>3514</b>	<b>3954</b>	<b>4454</b>
Heating capacity (EN14511) <sup>(1)</sup>	kW	185,0	205,0	234,0	234,0	273,0	305,0	328,0	373,0	415,0	464,0
Total input power (EN14511) <sup>(1)</sup>	kW	43,7	48,1	54,8	53,6	65,8	75,1	80,0	91,0	101,0	112,0
COP (EN14511) <sup>(1)</sup>	W/W	4,23	4,26	4,27	4,37	4,15	4,06	4,10	4,10	4,11	4,14
Energy Class <sup>(2)</sup>		A++	A++	A+	A++	A+	A+	A+	A+	A+	A+
SCOP <sup>(2)</sup>	kWh/kWh	4,10	4,10	3,80	4,20	3,60	3,60	3,80	3,70	3,70	3,70
η <sub>s,h</sub> <sup>(2)</sup>	%	161	161	149	165	141	141	149	145	145	145
Cooling capacity (EN14511) <sup>(3)</sup>	kW	160,0	175,0	197,0	195,0	229,0	254,0	271,0	306,0	352,0	387,0
Total input power (EN14511) <sup>(3)</sup>	kW	57,0	62,8	70,3	69,4	78,3	91,9	100,0	116,0	125,0	141,0
EER (EN14511) <sup>(3)</sup>	W/W	2,81	2,79	2,80	2,81	2,92	2,76	2,71	2,64	2,82	2,74
TER (EN14511) <sup>(4)</sup>	W/W	10,3	10,1	10,1	10,0	9,81	9,52	9,58	9,48	9,82	9,78
Sound power <sup>(5)</sup>	dB (A)	89	89	88	91	89	90	90	92	92	94
Sound pressure <sup>(6)</sup>	dB (A)	57	57	56	58	56	58	58	60	59	62
<b>HE/LS/RV P4U</b>		<b>1792</b>	<b>2012</b>	<b>2304</b>	<b>2312</b>	<b>2654</b>	<b>2954</b>	<b>3214</b>	<b>3514</b>	<b>3954</b>	<b>4454</b>
Heating capacity (EN14511) <sup>(1)</sup>	kW	184,0	204,0	233,0	231,0	272,0	304,0	326,0	371,0	413,0	461,0
Total input power (EN14511) <sup>(1)</sup>	kW	42,1	46,4	52,5	51,8	62,0	71,4	76,5	87,8	96,7	108,0
COP (EN14511) <sup>(1)</sup>	W/W	4,37	4,40	4,44	4,46	4,39	4,26	4,26	4,23	4,27	4,27
Energy Class <sup>(2)</sup>		A++	A++	A++	A++	A++	A++	A++	A++	A++	A++
SCOP <sup>(2)</sup>	kWh/kWh	4,40	4,40	4,30	4,40	4,00	4,20	4,20	4,20	4,20	4,10
η <sub>s,h</sub> <sup>(2)</sup>	%	173	173	169	173	157	165	165	165	165	161
Cooling capacity (EN14511) <sup>(3)</sup>	kW	158,0	173,0	194	192,0	227,0	252,0	269,0	304,0	349,0	384,0
Total input power (EN14511) <sup>(3)</sup>	kW	56,9	62,7	69,8	69,7	76,8	90,4	99,0	115,0	124,0	140,0
EER (EN14511) <sup>(3)</sup>	W/W	2,78	2,76	2,78	2,75	2,96	2,79	2,72	2,64	2,81	2,74
TER (EN14511) <sup>(4)</sup>	W/W	10,3	10,1	10,1	10,0	9,81	9,52	9,58	9,48	9,82	9,78
Sound power <sup>(5)</sup>	dB (A)	90	92	91	92	91	92	92	93	91	89
Sound pressure <sup>(6)</sup>	dB (A)	58	59	58	60	58	59	59	60	59	56
Power supply	V/Ph/Hz	400/3/50	400/3/50	400/3/50	400/3/50	400/3/50	400/3/50	400/3/50	400/3/50	400/3/50	400/3/50
Compressors / Circuits	n° / n°	2 / 1	2 / 1	4 / 2	2 / 1	4 / 2	4 / 2	4 / 2	4 / 2	4 / 2	4 / 2
Fans	n°	3	3	4	3	6	6	6	6	8	8
Refrigerant		R454B	R454B	R454B	R454B	R454B	R454B	R454B	R454B	R454B	R454B
Refrigerant charge	kg	37	47	25	59	32	32	32	31	37	41
Global warming potential (GWP)		466	466	466	466	466	466	466	466	466	466
Equivalent CO <sub>2</sub> charge	t	17,2	21,9	11,6	27,5	14,9	14,9	14,9	14,4	17,2	19,1
Water tank volume	l	500	500	500	500	500	500	500	500	500	500

Performances are referred to the following conditions:

- (1) Heating: Ambient temperature 7°C DB, 6°C WB, water temperature 30/35°C.
- (2) Average conditions, low temperature, variable - Reg EU 811/2013
- (3) Cooling: ambient air temperature 35°C, evaporator water temperature in/out 12/7 °C.

(4) TER: Total Energy Ratio - cold circuit 12/7°C, hot circuit 30/35°C.

(5) Sound power level in accordance with ISO 3744.

(6) Sound pressure level at 10 mt from the unit in free field conditions in accordance with ISO 3744.

Reversible heating/cooling version (RV)

LHE/P4

HA/XL/RV P4U		452	512	682	752	912	1102	1152	1352	1502	1612
Heating capacity (EN14511) <sup>(1)</sup>	kW	45,2	51,3	68,3	74,4	90,8	103,0	113,0	134,0	150,0	161,0
Total input power (EN14511) <sup>(1)</sup>	kW	11,1	12,4	15,5	17,4	21,2	24,0	26,5	31,3	35,8	38,0
COP (EN14511) <sup>(1)</sup>	W/W	4,07	4,14	4,41	4,28	4,28	4,29	4,26	4,28	4,19	4,24
Energy Class <sup>(2)</sup>		A++	A++	A++	A++	A++	A++	A++	A++	A++	A++
SCOP <sup>(2)</sup>	kWh/kWh	4,00	4,10	4,20	4,20	3,90	4,30	4,30	4,10	4,10	4,10
η <sub>s,h</sub> <sup>(2)</sup>	%	157	161	165	165	153	169	169	161	161	161
Cooling capacity (EN14511) <sup>(3)</sup>	kW	37,0	42,5	56,1	59,0	75,3	84,5	93,3	111,0	122,0	132,0
Total input power (EN14511) <sup>(3)</sup>	kW	14,3	16,7	21,7	25,6	26,7	31,0	35,8	38,3	45,4	49,6
EER (EN14511) <sup>(3)</sup>	W/W	2,59	2,54	2,59	2,30	2,82	2,73	2,61	2,90	2,69	2,66
TER (EN14511) <sup>(4)</sup>	W/W	9,61	9,84	10,2	9,82	10,1	9,91	10,1	9,86	9,57	9,80
Sound power <sup>(5)</sup>	dB (A)	72	71	71	72	74	76	78	80	81	81
Sound pressure <sup>(6)</sup>	dB (A)	40	40	40	41	43	44	46	48	49	49
<b>HE/XL/RV P4U</b>		<b>452</b>	<b>512</b>	<b>682</b>	<b>752</b>	<b>912</b>	<b>1102</b>	<b>1152</b>	<b>1352</b>	<b>1502</b>	<b>1612</b>
Heating capacity (EN14511) <sup>(1)</sup>	kW	44,8	51,4	68,6	74,5	90,1	102,0	112,0	133,0	149,0	159,0
Total input power (EN14511) <sup>(1)</sup>	kW	10,6	12,2	15,3	17,3	19,7	22,6	24,9	29,0	33,5	35,7
COP (EN14511) <sup>(1)</sup>	W/W	4,23	4,21	4,48	4,31	4,57	4,51	4,50	4,59	4,45	4,45
Energy Class <sup>(2)</sup>		A++	A++	A++	A++	A++	A++	A+++	A++	A++	A++
SCOP <sup>(2)</sup>	kWh/kWh	4,20	4,20	4,31	4,24	4,33	4,40	4,49	4,34	4,34	4,35
η <sub>s,h</sub> <sup>(2)</sup>	%	165	165	169	167	170	173	177	171	171	171
Cooling capacity (EN14511) <sup>(3)</sup>	kW	36,3	42,6	56,3	59,8	73,8	82,7	91,2	108,0	120,0	130,0
Total input power (EN14511) <sup>(3)</sup>	kW	14,2	16,5	21,5	25,1	26,1	30,7	35,5	37,5	44,5	48,7
EER (EN14511) <sup>(3)</sup>	W/W	2,56	2,58	2,62	2,38	2,83	2,69	2,57	2,88	2,70	2,67
TER (EN14511) <sup>(4)</sup>	W/W	9,61	9,84	10,2	9,82	10,1	9,91	10,1	9,86	9,57	9,80
Sound power <sup>(5)</sup>	dB (A)	72	71	71	72	74	76	78	80	81	81
Sound pressure <sup>(6)</sup>	dB (A)	40	40	40	41	43	44	46	48	49	49
Power supply	V/Ph/Hz	400/3/50	400/3/50	400/3/50	400/3/50	400/3/50	400/3/50	400/3/50	400/3/50	400/3/50	400/3/50
Compressors / Circuits	n° / n°	2 / 1	2 / 1	2 / 1	2 / 1	2 / 1	2 / 1	2 / 1	2 / 1	2 / 1	2 / 1
Fans	n°	2	2	2	2	2	2	2	3	3	3
Refrigerant		R454B	R454B	R454B	R454B	R454B	R454B	R454B	R454B	R454B	R454B
Refrigerant charge	kg	11	11	17	17	25	25	25	36	36	36
Global warming potential (GWP)		466	466	466	466	466	466	466	466	466	466
Equivalent CO <sub>2</sub> charge	t	5,1	5,1	7,9	7,9	11,6	11,6	11,6	16,8	16,8	16,8
Water tank volume	l	140	140	300	300	300	300	300	500	500	500
<b>HA/XL/RV P4U</b>		<b>1792</b>	<b>2012</b>	<b>2304</b>	<b>2312</b>	<b>2654</b>	<b>2954</b>	<b>3214</b>	<b>3514</b>	<b>3954</b>	<b>4454</b>
Heating capacity (EN14511) <sup>(1)</sup>	kW	182,0	201,0	230,0	228,0	269,0	301,0	322,0	367,0	408,0	459,0
Total input power (EN14511) <sup>(1)</sup>	kW	42,8	47,2	53,6	52,7	64,2	73,3	78,2	89,1	98,9	110,0
COP (EN14511) <sup>(1)</sup>	W/W	4,25	4,26	4,29	4,33	4,19	4,11	4,12	4,12	4,13	4,17
Energy Class <sup>(2)</sup>		A++	A++	A++	A++	A++	A++	A++	A++	A++	A++
SCOP <sup>(2)</sup>	kWh/kWh	4,20	4,20	4,00	4,20	3,90	3,90	4,00	4,00	4,00	3,90
η <sub>s,h</sub> <sup>(2)</sup>	%	165	165	157	165	153	153	157	157	157	153
Cooling capacity (EN14511) <sup>(3)</sup>	kW	154,0	171,0	191	188,0	222,0	247,0	263,0	294,0	342,0	374,0
Total input power (EN14511) <sup>(3)</sup>	kW	58,9	63,9	72,0	72,2	80,1	94,0	103,0	121,0	128,0	145,0
EER (EN14511) <sup>(3)</sup>	W/W	2,61	2,68	2,65	2,60	2,77	2,63	2,55	2,43	2,67	2,58
TER (EN14511) <sup>(4)</sup>	W/W	10,3	10,1	10,1	10,0	9,81	9,52	9,58	9,48	9,82	9,78
Sound power <sup>(5)</sup>	dB (A)	81	82	80	83	83	84	84	84	86	86
Sound pressure <sup>(6)</sup>	dB (A)	49	51	49	52	51	52	52	52	53	54
<b>HE/XL/RV P4U</b>		<b>1792</b>	<b>2012</b>	<b>2304</b>	<b>2312</b>	<b>2654</b>	<b>2954</b>	<b>3214</b>	<b>3514</b>	<b>3954</b>	<b>4454</b>
Heating capacity (EN14511) <sup>(1)</sup>	kW	180,0	200,0	233,0	226,0	263,0	293,0	313,0	354,0	397,0	436,0
Total input power (EN14511) <sup>(1)</sup>	kW	40,5	44,9	50,5	50,3	59,2	68,4	73,2	84,1	92,3	103,0
COP (EN14511) <sup>(1)</sup>	W/W	4,44	4,45	4,42	4,49	4,44	4,28	4,28	4,21	4,30	4,23
Energy Class <sup>(2)</sup>		A+++	A++	A++	A+++	A++	A++	A++	A++	A++	A++
SCOP <sup>(2)</sup>	kWh/kWh	4,48	4,40	4,43	4,46	4,32	4,33	4,35	4,31	4,33	4,30
η <sub>s,h</sub> <sup>(2)</sup>	%	176	173	174	175	170	170	171	169	170	169
Cooling capacity (EN14511) <sup>(3)</sup>	kW	151,0	166,0	187,0	181,0	219,0	244,0	259,0	286,0	337,0	367,0
Total input power (EN14511) <sup>(3)</sup>	kW	58,8	64,7	71,2	73,6	77,2	91,4	101,0	120,0	125,0	143,0
EER (EN14511) <sup>(3)</sup>	W/W	2,57	2,57	2,63	2,46	2,84	2,67	2,56	2,38	2,70	2,57
TER (EN14511) <sup>(4)</sup>	W/W	10,3	10,1	10,1	10,0	9,81	9,52	9,58	9,48	9,82	9,78
Sound power <sup>(5)</sup>	dB (A)	81	82	80	83	83	84	84	84	86	86
Sound pressure <sup>(6)</sup>	dB (A)	49	51	49	52	51	52	52	52	53	54
Power supply	V/Ph/Hz	400/3/50	400/3/50	400/3/50	400/3/50	400/3/50	400/3/50	400/3/50	400/3/50	400/3/50	400/3/50
Compressors / Circuits	n° / n°	2 / 1	2 / 1	4 / 2	2 / 1	4 / 2	4 / 2	4 / 2	4 / 2	4 / 2	4 / 2
Fans	n°	3	3	4	3	6	6	6	6	8	8
Refrigerant		R454B	R454B	R454B	R454B	R454B	R454B	R454B	R454B	R454B	R454B
Refrigerant charge	kg	37	47	25	59	32	32	32	31	37	41
Global warming potential (GWP)		466	466	466	466	466	466	466	466	466	466
Equivalent CO <sub>2</sub> charge	t	17,2	21,9	11,6	27,5	14,9	14,9	14,9	14,4	17,2	19,1
Water tank volume	l	500	500	500	500	500	500	500	500	500	500

Performances are referred to the following conditions:

- (1) Heating: Ambient temperature 7°C DB, 6°C WB, water temperature 30/35°C.
- (2) Average conditions, low temperature, variable - Reg EU 811/2013
- (3) Cooling: ambient air temperature 35°C, evaporator water temperature in/out 12/7 °C.

(4) TER: Total Energy Ratio - cold circuit 12/7°C, hot circuit 30/35°C.

(5) Sound power level in accordance with ISO 3744.

(6) Sound pressure level at 10 mt from the unit in free field conditions in accordance with ISO 3744.

Reversible heating/cooling version (RV)

HA/LS/RV P4S		452	512	682	752	912	1102	1152	1352	1502	1612
Heating capacity (EN14511) <sup>(1)</sup>	kW	45,4	51,4	68,7	74,6	87,9	101,0	112,0	129,0	150,0	161,0
Total input power (EN14511) <sup>(1)</sup>	kW	11,7	13,0	16,3	18,4	22,7	25,3	28,4	33,5	38,4	40,6
COP (EN14511) <sup>(1)</sup>	W/W	3,88	3,95	4,21	4,05	3,87	3,99	3,94	3,85	3,91	3,97
Energy Class <sup>(2)</sup>		A+	A+	A++	A++	A+	A++	A++	A+	A+	A+
SCOP <sup>(2)</sup>	kWh/kWh	3,68	3,74	4,08	4,00	3,52	3,85	3,86	3,69	3,69	3,75
η <sub>s,h</sub> <sup>(2)</sup>	%	144	147	160	157	138	151	151	145	145	147
Cooling capacity (EN14511) <sup>(3)</sup>	kW	37,7	43,2	57,1	61,0	76,7	86,9	96,0	112,0	125,0	136,0
Total input power (EN14511) <sup>(3)</sup>	kW	14,0	16,4	21,3	24,6	26,5	30,3	35,0	38,3	44,3	48,5
EER (EN14511) <sup>(3)</sup>	W/W	2,69	2,63	2,68	2,48	2,89	2,87	2,74	2,92	2,82	2,80
TER (EN14511) <sup>(4)</sup>	W/W	5,58	5,78	6,04	5,82	5,98	5,94	6,04	5,91	5,80	5,92
Sound power <sup>(5)</sup>	dB (A)	77	76	77	78	82	83	85	86	87	87
Sound pressure <sup>(6)</sup>	dB (A)	46	44	45	46	50	51	53	54	55	55
<b>HE/LS/RV P4S</b>		<b>452</b>	<b>512</b>	<b>682</b>	<b>752</b>	<b>912</b>	<b>1102</b>	<b>1152</b>	<b>1352</b>	<b>1502</b>	<b>1612</b>
Heating capacity (EN14511) <sup>(1)</sup>	kW	45,0	51,5	68,7	75,0	91,0	102,0	114,0	134,0	150,0	161,0
Total input power (EN14511) <sup>(1)</sup>	kW	11,2	13,0	16,3	18,4	21,4	24,5	27,0	31,6	36,6	38,9
COP (EN14511) <sup>(1)</sup>	W/W	4,02	3,96	4,21	4,08	4,25	4,16	4,22	4,24	4,10	4,14
Energy Class <sup>(2)</sup>		A++	A++	A++	A++	A++	A++	A++	A++	A++	A++
SCOP <sup>(2)</sup>	kWh/kWh	3,98	3,90	4,19	4,13	3,92	4,10	4,14	4,02	4,08	4,03
η <sub>s,h</sub> <sup>(2)</sup>	%	156	153	165	162	154	161	163	158	160	158
Cooling capacity (EN14511) <sup>(3)</sup>	kW	36,9	43,2	57,6	61,5	76,5	85,5	95,0	112,0	124,0	134,0
Total input power (EN14511) <sup>(3)</sup>	kW	14,1	16,5	21,2	24,5	25,8	30,3	34,6	37,3	43,6	48,1
EER (EN14511) <sup>(3)</sup>	W/W	2,62	2,62	2,72	2,51	2,97	2,82	2,75	3,00	2,84	2,79
TER (EN14511) <sup>(4)</sup>	W/W	6,19	5,78	6,04	5,82	5,98	5,94	6,04	5,91	5,80	5,92
Sound power <sup>(5)</sup>	dB (A)	78	79	81	82	86	87	88	89	89	90
Sound pressure <sup>(6)</sup>	dB (A)	46	47	49	50	54	55	56	57	56	57
Power supply	V/Ph/Hz	400/3/50	400/3/50	400/3/50	400/3/50	400/3/50	400/3/50	400/3/50	400/3/50	400/3/50	400/3/50
Compressors / Circuits	n° / n°	2 / 1	2 / 1	2 / 1	2 / 1	2 / 1	2 / 1	2 / 1	2 / 1	2 / 1	2 / 1
Fans	n°	2	2	2	2	2	2	2	3	3	3
Refrigerant		R454B	R454B	R454B	R454B	R454B	R454B	R454B	R454B	R454B	R454B
Refrigerant charge	kg	11	11	17	17	25	25	25	36	36	36
Global warming potential (GWP)		466	466	466	466	466	466	466	466	466	466
Equivalent CO <sub>2</sub> charge	t	5,1	5,1	7,9	7,9	11,6	11,6	11,6	16,8	16,8	16,8
Water tank volume	l	140	140	300	300	300	300	300	500	500	500
<b>HA/LS/RV P4S</b>		<b>1792</b>	<b>2012</b>	<b>2304</b>	<b>2312</b>	<b>2654</b>	<b>2954</b>	<b>3214</b>	<b>3514</b>	<b>3954</b>	<b>4454</b>
Heating capacity (EN14511) <sup>(1)</sup>	kW	181,0	200,0	226,0	226,0	261,0	297,0	319,0	365,0	404,0	454,0
Total input power (EN14511) <sup>(1)</sup>	kW	45,7	50,0	56,7	56,0	68,5	78,0	82,8	94,1	105,0	116,0
COP (EN14511) <sup>(1)</sup>	W/W	3,96	4,00	3,99	4,04	3,81	3,81	3,85	3,88	3,85	3,91
Energy Class <sup>(2)</sup>		A++	A++	A+	A++	A+	A+	A+	A+	A+	A+
SCOP <sup>(2)</sup>	kWh/kWh	3,99	3,98	3,68	4,04	3,51	3,55	3,69	3,69	3,60	3,63
η <sub>s,h</sub> <sup>(2)</sup>	%	157	156	144	159	137	139	145	145	141	142
Cooling capacity (EN14511) <sup>(3)</sup>	kW	160,0	175,0	197,0	195,0	229,0	254,0	271,0	306,0	352,0	387,0
Total input power (EN14511) <sup>(3)</sup>	kW	57,0	62,8	70,3	69,4	78,3	91,9	100,0	116,0	125,0	141,0
EER (EN14511) <sup>(3)</sup>	W/W	2,81	2,79	2,80	2,81	2,92	2,76	2,71	2,64	2,82	2,74
TER (EN14511) <sup>(4)</sup>	W/W	6,20	6,11	6,01	6,11	5,89	5,77	5,83	5,81	6,76	6,89
Sound power <sup>(5)</sup>	dB (A)	89	89	88	91	89	90	90	92	92	94
Sound pressure <sup>(6)</sup>	dB (A)	57	57	56	58	56	58	58	60	59	62
<b>HE/LS/RV P4S</b>		<b>1792</b>	<b>2012</b>	<b>2304</b>	<b>2312</b>	<b>2654</b>	<b>2954</b>	<b>3214</b>	<b>3514</b>	<b>3954</b>	<b>4454</b>
Heating capacity (EN14511) <sup>(1)</sup>	kW	182,0	202,0	227,0	230,0	261,0	298,0	320,0	366,0	405,0	455,0
Total input power (EN14511) <sup>(1)</sup>	kW	44,1	48,5	54,6	54,3	64,6	74,2	79,0	90,6	100,0	112,0
COP (EN14511) <sup>(1)</sup>	W/W	4,13	4,16	4,16	4,24	4,04	4,02	4,05	4,04	4,05	4,06
Energy Class <sup>(2)</sup>		A++	A++	A++	A++	A++	A++	A++	A++	A++	A++
SCOP <sup>(2)</sup>	kWh/kWh	4,25	4,20	4,12	4,20	3,92	4,01	4,05	4,06	4,04	4,01
η <sub>s,h</sub> <sup>(2)</sup>	%	167	165	162	165	154	157	159	159	159	157
Cooling capacity (EN14511) <sup>(3)</sup>	kW	158,0	173,0	194	192,0	227,0	252,0	269,0	304,0	349,0	384,0
Total input power (EN14511) <sup>(3)</sup>	kW	56,9	62,7	69,8	69,7	76,8	90,4	99,0	115,0	124,0	140,0
EER (EN14511) <sup>(3)</sup>	W/W	2,78	2,76	2,78	2,75	2,96	2,79	2,72	2,64	2,81	2,74
TER (EN14511) <sup>(4)</sup>	W/W	6,20	6,11	6,01	6,11	5,89	5,77	5,83	5,81	6,76	6,89
Sound power <sup>(5)</sup>	dB (A)	90	92	91	92	91	92	92	93	91	89
Sound pressure <sup>(6)</sup>	dB (A)	58	59	58	60	58	59	59	60	59	56
Power supply	V/Ph/Hz	400/3/50	400/3/50	400/3/50	400/3/50	400/3/50	400/3/50	400/3/50	400/3/50	400/3/50	400/3/50
Compressors / Circuits	n° / n°	2 / 1	2 / 1	4 / 2	2 / 1	4 / 2	4 / 2	4 / 2	4 / 2	4 / 2	4 / 2
Fans	n°	3	3	4	3	6	6	6	6	8	8
Refrigerant		R454B	R454B	R454B	R454B	R454B	R454B	R454B	R454B	R454B	R454B
Refrigerant charge	kg	37	47	25	59	32	32	32	31	37	41
Global warming potential (GWP)		466	466	466	466	466	466	466	466	466	466
Equivalent CO <sub>2</sub> charge	t	17,2	21,9	11,6	27,5	14,9	14,9	14,9	14,4	17,2	19,1
Water tank volume	l	500	500	500	500	500	500	500	500	500	500

Performances are referred to the following conditions:

- (1) Heating: Ambient temperature 7°C DB, 6°C WB, water temperature 30/35°C.
- (2) Average conditions, low temperature, variable - Reg EU 811/2013
- (3) Cooling: ambient air temperature 35°C, evaporator water temperature in/out 12/7 °C.

(4) TER: Total Energy Ratio - cold circuit 12/7°C, hot circuit 30/35°C.

(5) Sound power level in accordance with ISO 3744.

(6) Sound pressure level at 10 mt from the unit in free field conditions in accordance with ISO 3744.

Reversible heating/cooling version (RV)

LHE/P4

HA/XL/RV P4S		452	512	682	752	912	1102	1152	1352	1502	1612
Heating capacity (EN14511) <sup>(1)</sup>	kW	45,2	51,0	67,6	73,6	89,9	102,0	112,0	133,0	148,0	160,0
Total input power (EN14511) <sup>(1)</sup>	kW	11,5	13,0	16,2	18,2	22,2	25,0	27,6	32,8	37,9	39,9
COP (EN14511) <sup>(1)</sup>	W/W	3,93	3,92	4,17	4,04	4,05	4,08	4,06	4,05	3,91	4,01
Energy Class <sup>(2)</sup>		A++	A++	A++	A++	A+	A++	A++	A++	A++	A++
SCOP <sup>(2)</sup>	kWh/kWh	3,88	3,97	4,07	4,02	3,79	4,12	4,14	3,98	3,95	4,02
η <sub>s,h</sub> <sup>(2)</sup>	%	152	156	160	158	149	162	163	156	155	158
Cooling capacity (EN14511) <sup>(3)</sup>	kW	37,0	42,5	56,1	59,0	75,3	84,5	93,3	111,0	122,0	132,0
Total input power (EN14511) <sup>(3)</sup>	kW	14,3	16,7	21,7	25,6	26,7	31,0	35,8	38,3	45,4	49,6
EER (EN14511) <sup>(3)</sup>	W/W	2,59	2,54	2,59	2,30	2,82	2,73	2,61	2,90	2,69	2,66
TER (EN14511) <sup>(4)</sup>	W/W	5,58	5,78	6,04	5,82	5,98	5,94	6,04	5,91	5,80	5,92
Sound power <sup>(5)</sup>	dB (A)	72	71	71	72	74	76	78	80	81	81
Sound pressure <sup>(6)</sup>	dB (A)	40	40	40	41	43	44	46	48	49	49
<b>HE/XL/RV P4S</b>		<b>452</b>	<b>512</b>	<b>682</b>	<b>752</b>	<b>912</b>	<b>1102</b>	<b>1152</b>	<b>1352</b>	<b>1502</b>	<b>1612</b>
Heating capacity (EN14511) <sup>(1)</sup>	kW	44,6	51,2	68,2	74,1	89,5	101,0	111,0	132,0	148,0	158,0
Total input power (EN14511) <sup>(1)</sup>	kW	11,0	12,7	16,0	18,0	20,6	23,6	26,0	30,5	35,3	37,4
COP (EN14511) <sup>(1)</sup>	W/W	4,05	4,03	4,26	4,12	4,34	4,28	4,27	4,33	4,19	4,22
Energy Class <sup>(2)</sup>		A++	A++	A++	A++	A++	A++	A++	A++	A++	A++
SCOP <sup>(2)</sup>	kWh/kWh	4,00	4,02	4,19	4,13	4,24	4,35	4,39	4,29	4,27	4,24
η <sub>s,h</sub> <sup>(2)</sup>	%	157	158	165	162	167	171	173	169	168	167
Cooling capacity (EN14511) <sup>(3)</sup>	kW	36,3	42,6	56,3	59,8	73,8	82,7	91,2	108,0	120,0	130,0
Total input power (EN14511) <sup>(3)</sup>	kW	14,2	16,5	21,5	25,1	26,1	30,7	35,5	37,5	44,5	48,7
EER (EN14511) <sup>(3)</sup>	W/W	2,56	2,58	2,62	2,38	2,83	2,69	2,57	2,88	2,70	2,67
TER (EN14511) <sup>(4)</sup>	W/W	6,19	5,78	6,04	5,82	5,98	5,94	6,04	5,91	5,80	5,92
Sound power <sup>(5)</sup>	dB (A)	72	71	71	72	74	76	78	80	81	81
Sound pressure <sup>(6)</sup>	dB (A)	40	40	40	41	43	44	46	48	49	49
Power supply	V/Ph/Hz	400/3/50	400/3/50	400/3/50	400/3/50	400/3/50	400/3/50	400/3/50	400/3/50	400/3/50	400/3/50
Compressors / Circuits	n° / n°	2 / 1	2 / 1	2 / 1	2 / 1	2 / 1	2 / 1	2 / 1	2 / 1	2 / 1	2 / 1
Fans	n°	2	2	2	2	2	2	2	3	3	3
Refrigerant		R454B	R454B	R454B	R454B	R454B	R454B	R454B	R454B	R454B	R454B
Refrigerant charge	kg	11	11	17	17	25	25	25	36	36	36
Global warming potential (GWP)		466	466	466	466	466	466	466	466	466	466
Equivalent CO <sub>2</sub> charge	t	5,1	5,1	7,9	7,9	11,6	11,6	11,6	16,8	16,8	16,8
Water tank volume	l	140	140	300	300	300	300	300	500	500	500
<b>HA/XL/RV P4S</b>		<b>1792</b>	<b>2012</b>	<b>2304</b>	<b>2312</b>	<b>2654</b>	<b>2954</b>	<b>3214</b>	<b>3514</b>	<b>3954</b>	<b>4454</b>
Heating capacity (EN14511) <sup>(1)</sup>	kW	181,0	200,0	229,0	227,0	267,0	300,0	320,0	365,0	407,0	456,0
Total input power (EN14511) <sup>(1)</sup>	kW	44,2	49,3	55,9	55,0	66,8	76,6	80,9	92,0	101,0	113,0
COP (EN14511) <sup>(1)</sup>	W/W	4,10	4,06	4,10	4,13	4,00	3,92	3,96	3,97	4,03	4,04
Energy Class <sup>(2)</sup>		A++	A++	A++	A++	A+	A+	A++	A++	A++	A++
SCOP <sup>(2)</sup>	kWh/kWh	4,09	4,09	3,86	4,09	3,82	3,79	3,89	3,88	3,85	3,84
η <sub>s,h</sub> <sup>(2)</sup>	%	161	161	151	161	150	149	153	152	151	151
Cooling capacity (EN14511) <sup>(3)</sup>	kW	154,0	171,0	191	188,0	222,0	247,0	263,0	294,0	342,0	374,0
Total input power (EN14511) <sup>(3)</sup>	kW	58,9	63,9	72,0	72,2	80,1	94,0	103,0	121,0	128,0	145,0
EER (EN14511) <sup>(3)</sup>	W/W	2,61	2,68	2,65	2,60	2,77	2,63	2,55	2,43	2,67	2,58
TER (EN14511) <sup>(4)</sup>	W/W	6,20	6,11	6,01	6,11	5,89	5,77	5,83	5,81	6,76	6,76
Sound power <sup>(5)</sup>	dB (A)	81	82	80	83	83	84	84	84	86	86
Sound pressure <sup>(6)</sup>	dB (A)	49	51	49	52	51	52	52	52	53	54
<b>HE/XL/RV P4S</b>		<b>1792</b>	<b>2012</b>	<b>2304</b>	<b>2312</b>	<b>2654</b>	<b>2954</b>	<b>3214</b>	<b>3514</b>	<b>3954</b>	<b>4454</b>
Heating capacity (EN14511) <sup>(1)</sup>	kW	179,0	199,0	222,0	225,0	260,0	291,0	312,0	351,0	396,0	434,0
Total input power (EN14511) <sup>(1)</sup>	kW	42,1	47,0	52,7	52,7	61,6	71,7	75,9	87,0	95,3	107,0
COP (EN14511) <sup>(1)</sup>	W/W	4,25	4,23	4,21	4,27	4,22	4,06	4,11	4,03	4,16	4,06
Energy Class <sup>(2)</sup>		A++	A++	A++	A++	A++	A++	A++	A++	A++	A++
SCOP <sup>(2)</sup>	kWh/kWh	4,33	4,33	4,37	4,31	4,14	4,18	4,18	4,19	4,20	4,07
η <sub>s,h</sub> <sup>(2)</sup>	%	170	170	172	169	163	164	164	165	165	160
Cooling capacity (EN14511) <sup>(3)</sup>	kW	151,0	166,0	187,0	181,0	219,0	244,0	259,0	286,0	337,0	367,0
Total input power (EN14511) <sup>(3)</sup>	kW	58,8	64,7	71,2	73,6	77,2	91,4	101,0	120,0	125,0	143,0
EER (EN14511) <sup>(3)</sup>	W/W	2,57	2,57	2,63	2,46	2,84	2,67	2,56	2,38	2,70	2,57
TER (EN14511) <sup>(4)</sup>	W/W	6,20	6,11	6,01	6,11	5,89	5,77	5,83	5,81	6,76	6,89
Sound power <sup>(5)</sup>	dB (A)	81	82	80	83	83	84	84	84	86	86
Sound pressure <sup>(6)</sup>	dB (A)	49	51	49	52	51	52	52	52	53	54
Power supply	V/Ph/Hz	400/3/50	400/3/50	400/3/50	400/3/50	400/3/50	400/3/50	400/3/50	400/3/50	400/3/50	400/3/50
Compressors / Circuits	n° / n°	2 / 1	2 / 1	4 / 2	2 / 1	4 / 2	4 / 2	4 / 2	4 / 2	4 / 2	4 / 2
Fans	n°	3	3	4	3	6	6	6	6	8	8
Refrigerant		R454B	R454B	R454B	R454B	R454B	R454B	R454B	R454B	R454B	R454B
Refrigerant charge	kg	37	47	25	59	32	32	32	31	37	41
Global warming potential (GWP)		466	466	466	466	466	466	466	466	466	466
Equivalent CO <sub>2</sub> charge	t	17,2	21,9	11,6	27,5	14,9	14,9	14,9	14,4	17,2	19,1
Water tank volume	l	500	500	500	500	500	500	500	500	500	500

Performances are referred to the following conditions:

- (1) Heating: Ambient temperature 7°C DB, 6°C WB, water temperature 30/35°C.
- (2) Average conditions, low temperature, variable - Reg EU 811/2013
- (3) Cooling: ambient air temperature 35°C, evaporator water temperature in/out 12/7 °C.

(4) TER: Total Energy Ratio - cold circuit 12/7°C, hot circuit 30/35°C.

(5) Sound power level in accordance with ISO 3744.

(6) Sound pressure level at 10 mt from the unit in free field conditions in accordance with ISO 3744.

## COMPONENTS

### FRAME

All units are made from hot-galvanised sheet steel, painted with polyurethane powder enamel and stoved at 180°C to provide maximum protection against corrosion. The frame is self-supporting with removable panels. All screws and rivets used are made from stainless steel. The standard colour of the units is RAL9018.

### REFRIGERANT CIRCUIT

The refrigerant circuit is assembled using internationally recognised brand name components with all brazing and welding being performed in accordance with ISO 97/23. The refrigerant utilised is R454B. The refrigerant circuit includes: sight glass, filter drier, electronic expansion valves, 4 way reversing valve, check valves, liquid receiver, liquid separator, schrader valves for maintenance and control, pressure safety device (for compliance with PED regulations).

### COMPRESSORS

The compressors are scroll type, with crankcase resistance and thermal protection, installed in a separate compartment from the airflow in order to reduce noise. When the unit is on stand-by mode, the crankcase heater is always powered. Through the unit's front panel, it is possible to inspect and repair the compressors even when the unit is running.

The compressors used are tandem type. This solution allows a significantly higher efficiency with partial loads compared to the option with independent refrigerant circuits. The control system constantly monitors the discharge temperature of the single compressors.

### SOURCE HEAT EXCHANGER

The source heat exchanger is made from 3/8" copper pipes and 0,1mm at least thick aluminium fins with the tubes being mechanically expanded into the aluminium fins in order to maximise heat transfer. Furthermore, the design guarantees a low air side pressure drop thus enabling the use of low rotation speed (and hence low noise) fans. All heat exchangers are supplied standard with fins hydrophilic coating "Blue Fins".

### USER CIRCUIT HEAT EXCHANGERS

The user heat exchanger is a braze welded, plate type heat exchanger, manufactured from AISI 316 stainless steel. The use of this type of exchanger results in a massive reduction of the refrigerant charge of the unit compared to a traditional shell-in-tube type. A further advantage is a reduction in the overall dimensions of the unit. The exchangers are factory insulated with flexible close cell material and can be fitted with an antifreeze heater (accessory). Each exchanger is fitted with a temperature sensor on the discharge water side for antifreeze protection.

### FANS

The fans are direct drive axial type with aerofoil blades, are statically and dynamically balanced and are supplied complete with a safety fan guard complying with the requirements of EN 60335. They are fixed to the unit frame via rubber anti-vibration mountings. The electric motors, in HA versions are 6 poles type and a phase-cut regulator controls their speed of rotation to increase energy efficiency and allow them to be used over a wider operating range. In the HE versions, the fans are electronic type, with permanent magnet motors with an integrated driver that modulates the speed of rotation. The motors are fitted with integrated thermal overload protection and have a moisture protection rating of IP 54.

### MICROPROCESSORS

All units are supplied as standard with microprocessor controls. The microprocessor controls the following functions: control of the water temperature, antifreeze protection, compressor timing, compressor automatic starting sequence (For multiple

compressors), alarm reset.

The control panel is supplied with display showing all operational icons. The microprocessor is set for automatic defrost (when operating in severe ambient conditions) and for summer/ winter change over. The control also manages the integration with other heating sources (electric heaters, boilers, solar panels etc) and both the heating circuit pump and the domestic hot water circuit pump. If required (available as an option), the microprocessor can be configured in order for it to connect to a site BMS system thus enabling remote control and management.

### ELECTRIC ENCLOSURE

The enclosure is manufactured in order to comply with the requirements of the electromagnetic compatibility standards 2014/35/UE and 2014/30/UE. Access to the enclosure is achieved by removing the front panel of the unit. The following components are supplied as standard on all units: main switch, a sequence relay that disables the power supply in the event that the phase sequence is incorrect (scroll compressors can be damaged if they rotate in the wrong direction), thermal overloads (protection of pumps and fans), compressor fuses, control circuit automatic breakers, compressor contactors, fan contactors and pump contactors. The terminal board has volt free contacts for remote ON-OFF, Summer/ winter change over (heat pumps only) and general alarm.

### CONTROL AND PROTECTION DEVICES

All units are standardly equipped with several control and safety devices: water return temperature sensor, installed on the water return pipe of the system, and anti-freeze probe, installed on the water supply pipe to the system high-pressure switch with automatic reset. There are also included a low-pressure automatic reset, pressure transducer (used to optimize the defrosting cycle and modulate the rotation speed of the fans according to external conditions), Freon side safety device, compressor thermal protection, fan thermal protection, flow switch, and external air compensation probe.

### LEAK DETECTOR

When the unit is powered ON, the sensor is warmed up/initialised (duration approx. 1min.).

During this period, the LEDs inside the sensor blink, the refrigerant leakage alarm is notified and the 24Vac auxiliary circuit is switched off. After this period, if in the absence of any further feedback from the sensor, the PLC control is powered up and the unit is ready to operate. If refrigerant leaks occur, the sensor is activated and the power supply to the control PLC is immediately switched off until the sensor indicates the refrigerant is still present.

## VERSIONI

### Versione supersilenziata HA/XL HE/XL

All XL super silenced units are supplied equipped with a special vibration-damping system consisting of a floating basement placed upon the unit's frame, through the interposition of high-damping steel springs.

The compressors are housed on this floating base and are in turn fixed by means of rubber anti-vibration supports.

The enclosure is manufactured from galvanized steel sandwich panels that have a micro-perforated inner skin and a core of 30 mm thick, high density (25 kg/m<sup>3</sup>) soundproofing mat. The entire arrangement provides a double damping system and acoustic attenuation. The compressor refrigerant pipes are connected to the refrigerant circuit through "anaconda" flexible connections. Flexible connections are also used on the water pipework within the unit. The combination of these systems results in an overall noise reduction in the region of 6-8 dB(A) compared to units in standard configuration.

### RV Version

Reversible heating/cooling unit, with cycle reversal on the cooling circuit.

### HA Version

High efficiency version, according to current standard. Unit equipped with AC fans.

### HE Version

High efficiency version, according to current standard. Unit equipped with EC fans.

### LS Version

This version includes the complete acoustic insulation of the unit with compressor jackets and insulating material made with high density media and the interposition of heavy bitumen layer.

### P4U Version

The P4U units use 4 hydraulic connections and are used in modern 4-pipe systems. In these systems, cold and hot water is always available (in every period of the year) and present in the specific hydraulic circuit. These systems allow the simultaneous production of cold water and hot water using 4 hydraulic connections, 2 connections are related to the hot water circuit, 2 connections are related to the cold water circuit. The plant thus conceived is able to heat and, at the same time, if required, to cool with very high energy efficiencies. In this configuration, however, the units are also able to produce hot or cold water separately at any time of the year.

The units are supplied with 2 heat exchangers, one dedicated to the production of cold water and one dedicated to the production of hot water. The operating modes are:

**1. User water heating:** The unit behaves like a normal air/water heat pump in heating mode, using the finned heat exchanger as the source and the A plate heat exchanger as user.

**2. User water cooling:** The unit behaves like a normal air / water chiller in cooling mode, using the finned exchanger as the source and the B plate heat exchanger as user.

**3. Simultaneous user Cooling + heating:** The unit behaves like a water / water heat pump, using the plate heat exchanger B as the cold user and the plate heat exchanger A as hot user. This version is not able to produce domestic hot water.

## P4U VERSION

User water heating

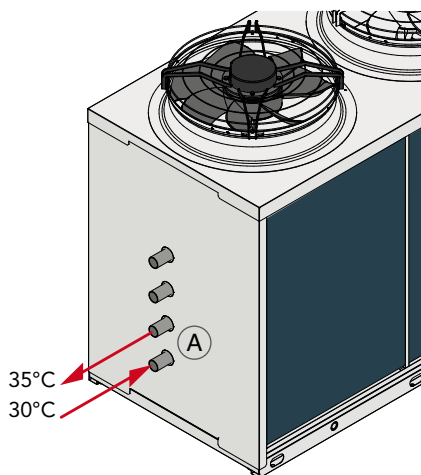

User water cooling

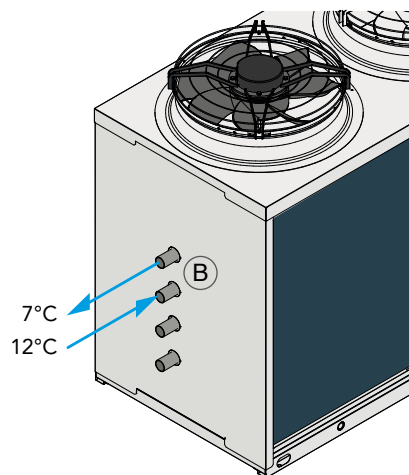

Simultaneous user Cooling + heating

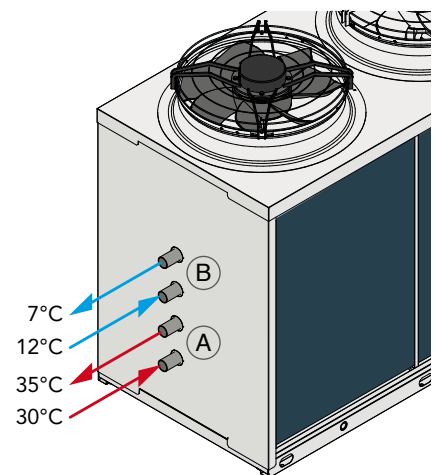

The above scheme is for illustrative purposes only. For the correct pipes placement, please refer to the units technical manual.

## OPERATION LIMITS

### P4S Version

The P4S units have been designed to meet the needs of 2 + 2 pipe systems (2 user side pipes, 2 domestic hot water pipes) throughout the year. The units are supplied with 2 exchangers, one dedicated to the production of the user cold and hot water and one dedicated to the production of domestic hot water only (D.H.W.). The production of domestic hot water always has priority. In winter mode the activation of D.H.W. production temporarily stops the production of the user hot water, which is restored when the D.H.W. accumulation reaches the temperature set. In summer mode the unit will switch to cooling (by activating the reverse cycle valve installed in the refrigerant circuit) and any request for domestic hot water will allow, at the same time, the production of cold water. In this operating mode, the system can simultaneously produce cold water and domestic hot water. Domestic hot water, in summer mode, is produced by heat recovery and therefore free of charge. When the temperature measured by the D.H.W. sensor reaches the set, the D.H.W. water pump is stopped and normal operation is restored in cooling mode. The operating modes are:

**1. User water heating:** The unit behaves like a normal air/water heat pump in heating mode, using the finned heat exchanger as the source and the A plate heat exchanger as user.

**2. User water cooling:** The unit behaves like a normal air/water chiller in cooling mode, using the finned heat exchanger as the source and the A plate heat exchanger as user.

**3. Domestic hot water production (D.H.W.):** The unit behaves like a normal air / water heat pump in heating mode, using the finned heat exchanger as the source and as a user the plate heat exchanger B (a special D.H.W. heat exchanger that works with a higher set point).

**4. User water cooling + D.H.W. production:** The unit behaves like a water / water heat pump, using the plate heat exchanger A as the cold user and the plate heat exchanger B as D.H.W. production).

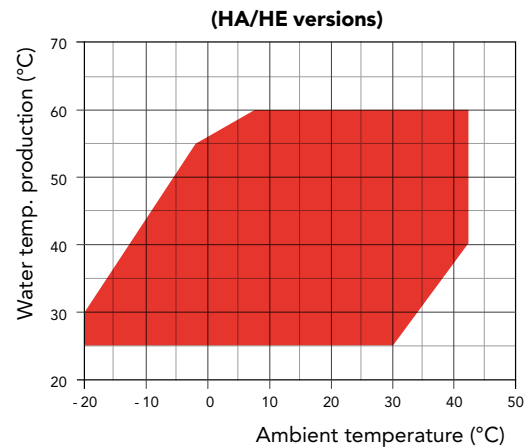

■ Heating mode

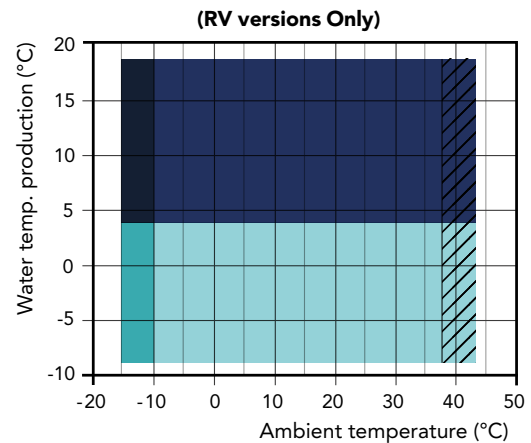

■ Cooling mode (only HE version)  
 ■ Cooling mode  
 ■ Cooling mode with glycol (only HE/BT version)  
 ■ Cooling mode with glycol (only BT version)  
 ▨ Possible noise increase for XL versions

### P4S VERSION

User water heating

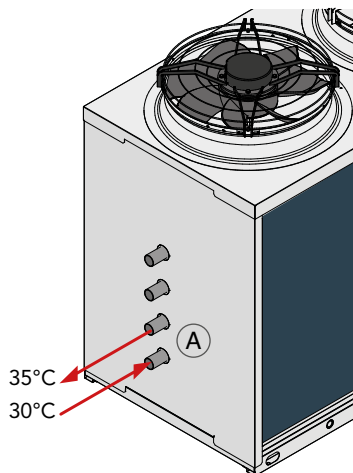

User water cooling

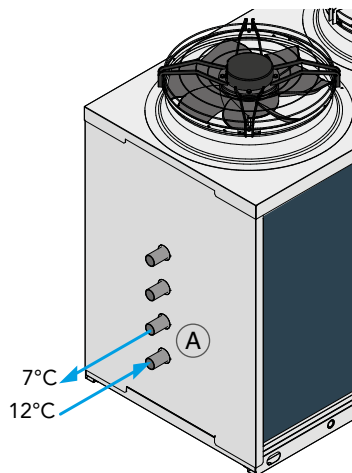

Domestic hot water production (D.H.W.)

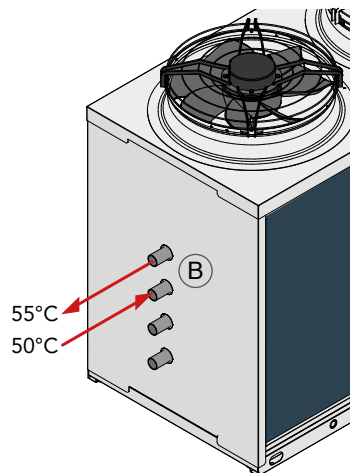

User water cooling + D.H.W. production

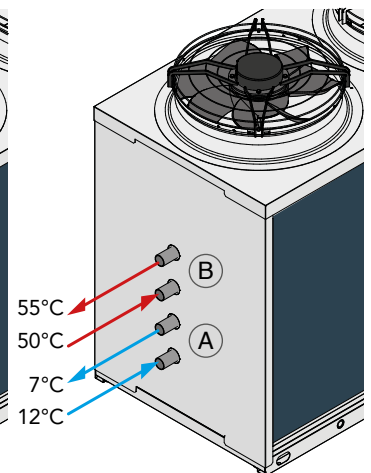

The above scheme is for illustrative purposes only. For the correct pipes placement, please refer to the units technical manual.

## ACCESSORIES

LHE/P4

LHE HA-HE /HH-RV		F1	F2	F3	F4	F5	F6	F7
Flow switch		●	●	●	●	●	●	●
Floating frame technology - LS version		-	-	-	-	-	-	-
Floating frame technology - XL version		●	●	●	●	●	●	●
Hydraulic kit with storage tank and one low-pressure pump	A1LLU	◇	◇	◇	◇	◇	◇	◇
Hydraulic kit with one low-pressure pump for recovery circuit	A1LPR	◇	◇	◇	◇	◇	◇	◇
Hydraulic kit with one low-pressure pump	A1LPU	◇	◇	◇	◇	◇	◇	◇
Hydraulic kit with 1 pump - recovery circuit	A1NTR	□	□	□	□	□	□	□
Hydraulic kit with one pump without tank - user circuit	A1NTU	□	□	□	□	□	□	□
Hydraulic kit with inverter pump recovery circuit	A1VSR	-	-	-	-	-	○	○
User circuit hydraulic kit, one inverter pump, no tank	A1VSU	○	○	○	○	○	○	○
User circuit hydraulic kit + inverter centrifugal pump	A1VVU	○	○	○	○	○	○	○
Hydraulic kit with one pump with tank	A1ZZU	□	□	□	□	□	□	□
Hydraulic kit with 2 pumps - recovery circuit	A2NTR	□	□	□	□	□	□	□
Hydraulic kit with two pumps without tank - user circuit	A2NTU	□	□	□	□	□	□	□
Hydraulic kit with two pumps with tank	A2ZZU	□	□	□	□	□	□	□
Condensate discharge drip tray with antifreeze heater	BRCA	○	○	○	○	○	○	○
4-connection tank and low-pressure pump	BUF4A	◇	◇	◇	◇	◇	◇	◇
Low Temperature Operating	BT	○	○	○	○	○	○	○
Fans regulation by phase cut (HA version)	DCCF	●	●	●	●	●	●	●
Refrigerant leakage detector	DFR	●	●	●	●	●	●	●
Electronic soft starter	DSSE	○	○	○	○	○	○	○
Double safety valve	DSV	○	○	○	○	○	○	○
Coil protection grid	GBPE	○	○	○	○	○	○	○
WIFI Application	HIPRO.web	○	○	○	○	○	○	○
Display	HMI.PRO	●	●	●	●	●	●	●
Serial interface card RS485	INSE	●	●	●	●	●	●	●
Rubber vibration dampers	KAVG	○	○	○	○	○	○	○
Spring vibration dampers	KAVM	○	○	○	○	○	○	○
COP internal optimizer kit	KCOP	○	○	○	○	○	○	○
Lifting rings kit	KGS	●	●	●	●	●	●	●
Safety valve ducting aid kit	KCSV	●	●	●	●	●	●	●
Double safety valve ducting aid kit	KCDV	○	○	○	○	○	○	○
Antifreeze recovery kit	KPR	○	○	○	○	○	○	○
Tank antifreeze kit	KPSU	○	○	○	○	○	○	○
User antifreeze kit	KPU	○	○	○	○	○	○	○
Victaulic kit	KVICT	-	-	-	-*	●	●	●
Pressure gauges	MAML	○	○	○	○	○	○	○
Remote control panel	PCRL	○	○	○	○	○	○	○
Shut-off valve on compressor discharging side	RDCO	○	○	○	○	○	○	○
Master-slave control system	SGRS	○	○	○	○	○	○	○
DHW probe kit	SOND1	●	●	●	●	●	●	●
E.C. fans - HA versions	VECE	-	-	-	-	-	-	-
E.C. fans - HE versions	VECE	●	●	●	●	●	●	●
Electronic expansion valve	VTEE	●	●	●	●	●	●	●

● Standard ○ Optional □ Optional only in the LS version ◇ Optional only in the XL version - Not available  
\* Excluding P2S version

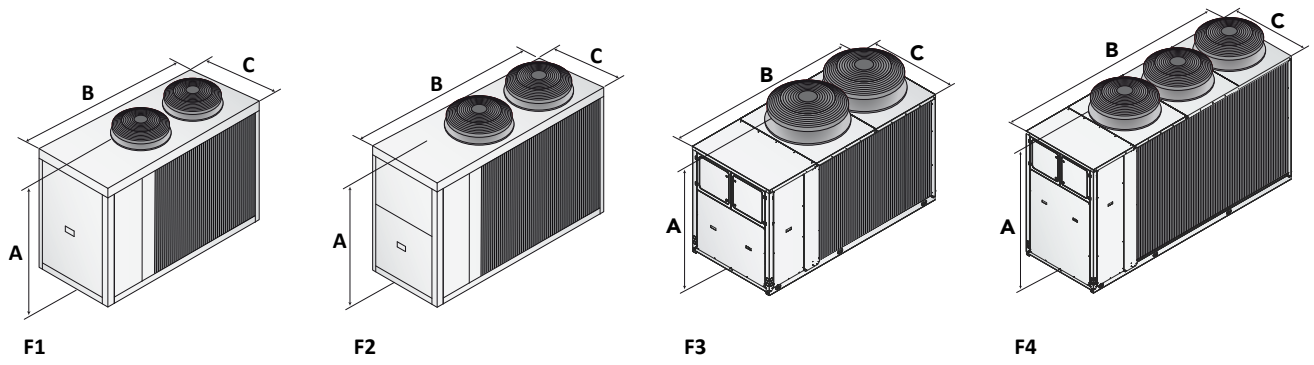

	452	512	682	752	912	1102	1152	1352	1502	1612
A (mm)	1838	1838	1955	1955	1955	1955	1955	1955	1955	1955
B (mm)	2400	2400	3000	3000	3000	3000	3000	4295	4295	4295
C (mm)	1265	1265	1265	1265	1265	1265	1265	1265	1265	1265
Kg	680	689	938	944	1162	1170	1176	1785	1811	1825
<b>FRAME</b>	<b>F1</b>	<b>F1</b>	<b>F2</b>	<b>F2</b>	<b>F3</b>	<b>F3</b>	<b>F3</b>	<b>F4</b>	<b>F4</b>	<b>F4</b>

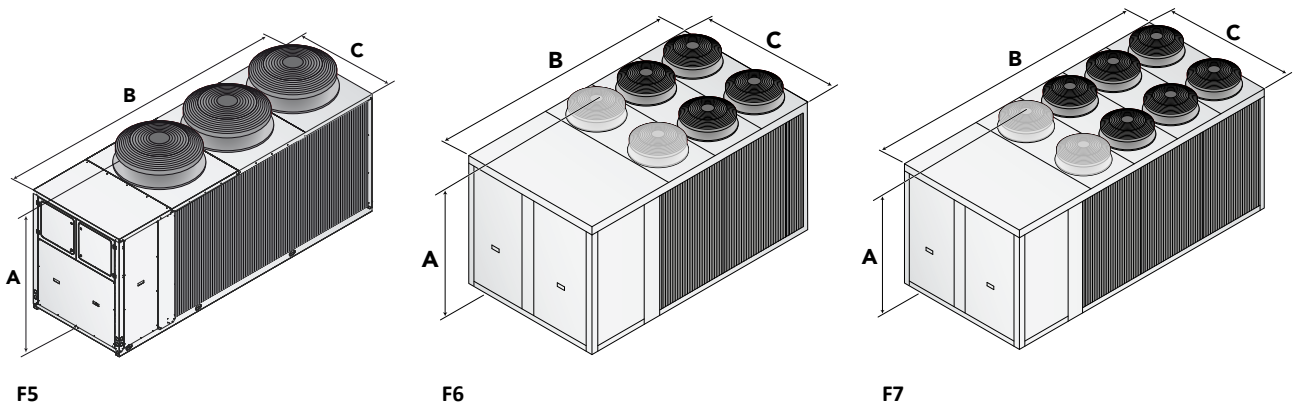

	1792	2012	2304	2312	2654	2954	3214	3514	3954	4454
A (mm)	1955	2355	2415	2355	2415	2415	2415	2415	2415	2415
B (mm)	4295	4296	4515	4296	4515	4515	4515	4515	5557	5557
C (mm)	1265	1265	2310	1265	2310	2310	2310	2310	2310	2310
Kg	1879	1924	1940	3433	3519	3609	3724	3752	4044	4072
<b>FRAME</b>	<b>F4</b>	<b>F5</b>	<b>F6</b>	<b>F5</b>	<b>F6</b>	<b>F6</b>	<b>F6</b>	<b>F6</b>	<b>F7</b>	<b>F7</b>

# GPE N

**HIGH EFFICIENCY AIR TO WATER MULTIPURPOSE UNIT AND 4 PIPE HEAT PUMPS**  
EQUIPPED WITH SCROLL COMPRESSOR AND AXIAL FANS WITH LOW GWP REFRIGERANT

Heating power from 80 kW to 1260 kW

R410A

R454B

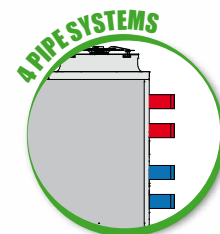

Multipurpose units, ideal for all installed applications where simultaneous production of hot and cold water is required, through the use of dedicated, independent circuits in 2- or 4-pipe hydronic systems. The polyvalent represents an effective and convenient alternative to traditional solutions ( Boiler + Chiller ) with a particular energy benefit in the conditions of demand for both fluids, hot and cold. Multiscroll technology allows to reach great efficiency improvements at part load. All the units are totally factory assembled and tested, following specific quality procedures. Besides they are totally hydraulic, cooling and electrical connected permitting a quick installation once on site. Before the test the cooling circuits of each unit are subjected to a pressure test and then charged with Refrigerant R410A or R454B and non-freezing oil.

## VERSIONS

**HE** High efficiency, EC fans.  
**U** Ultra low noise.

## TECHNICAL DATA

GPE N Kc		601	801	1001	1201	1401	1601	1801	1802	2002	2101	2302	2502	2802
Heating capacity (EN14511) <sup>(1)</sup>	kW	83,6	99,1	124,0	151,0	178,0	199,0	227,0	221,0	254,0	258,0	283	312	342
Total input power (EN14511) <sup>(1)</sup>	kW	19,6	24,7	30,1	35,9	42,3	48,3	53,5	52,9	57,5	60,8	65,1	72,5	84,1
Input current	A	41,1	48,0	59,2	67,8	80,3	89,6	98,1	106	112	112	125	138	160
COP (EN14511) <sup>(1)</sup>	W/W	4,27	4,01	4,12	4,21	4,21	4,12	4,24	4,18	4,42	4,24	4,35	4,30	4,07
SCOP	W/W	3,50	3,40	3,50	3,70	3,70	3,70	3,70	3,60	3,90	3,70	3,90	4,00	3,70
η <sub>s,h</sub> <sup>(2)</sup>	%	137	133	137	145	145	145	145	141	153	145	153	157	145
Cooling capacity (EN14511) <sup>(3)</sup>	kW	73,6	84,4	104,0	126,0	148,0	167,0	186,0	184,0	209,0	217,0	237	256	295
Total input power (EN14511) <sup>(3)</sup>	kW	22,9	30,4	35,9	44,1	50,7	59,6	66,2	63,4	66,8	72,3	77,2	86,7	104,0
Input current	A	44,4	55,5	65,8	77,5	90,1	104	114	118	122	126	138	153	182
EER	W/W	3,21	2,78	2,90	2,86	2,92	2,80	2,81	2,90	3,13	3,00	3,07	2,95	2,84
Cooling capacity (EN14511) <sup>(4)</sup>	kW	74,7	94,2	113,0	139,0	161,0	185,0	207,0	199,0	222,0	233,0	256	279	325
Heating capacity (EN14511) <sup>(4)</sup>	kW	90,9	115,0	139,0	171,0	198,0	229,0	256,0	245,0	272,0	287,0	313	343	400
Total input power (EN14511) <sup>(4)</sup>	kW	16,3	21,6	27,3	32,9	37,7	44,4	49,8	46,2	50,6	55,6	58,3	65,9	76,1
Input current	A	31,7	38,8	49,6	58,1	66,0	76,2	84,6	86,1	90,4	93,9	104	117	134
TER	W/W	10,2	9,69	9,23	9,42	9,52	9,32	9,30	9,61	9,76	9,35	9,76	9,44	9,53
Sound power <sup>(5)</sup>	dB(A)	83	86	86	88	89	90	90	88	90	91	90	90	91
Sound pressure <sup>(6)</sup>	dB(A)	51	54	54	56	57	58	58	56	58	59	58	58	58
Power supply	V/ph/Hz	400/3/50												
Circuits	n°	1	1	1	1	1	1	1	2	2	1	2	2	2
Compressors	n°	2	2	2	2	2	2	2	4	4	2	4	4	4
Fans	n°	2	2	2	2	3	3	3	6	6	4	6	6	8
Refrigerant		R410A	R410A	R410A	R410A	R410A	R410A	R410A	R410A	R410A	R410A	R410A	R410A	R410A
Refrigerant charge	kg	22	23	34	47	51	51	69	60	90	68	92	90	84
Global warming potential	GWP	2088	2088	2088	2088	2088	2088	2088	2088	2088	2088	2088	2088	2088
Equivalent CO <sub>2</sub> charge	t	45,9	48,0	71,0	98,1	106,5	106,5	144,1	125,3	187,9	142,0	192,1	187,9	175,4
Frame		1	1	1	1	2	2	2	4	4	3	4	4	5
Transport weight	kg	1017	1086	1169	1363	1517	1532	1824	1906	2183	1818	2131	2616	2776
Operating weight	kg	1023	1092	1176	1371	1525	1541	1835	1918	2195	1830	2147	2633	2793

GPE N Kc		3202	3602	4202	4802	5202	5602	6002	7004	7504	8504	9504	1004	11004
Heating capacity (EN14511) <sup>(1)</sup>	kW	402	442	493	593	634	682	711	818,0	884,6	982,6	1100,0	1181,0	1264,8
Total input power (EN14511) <sup>(1)</sup>	kW	95,9	108,0	118,0	142,0	152,0	168,0	215,0	202,5	216,4	237,0	264,4	285,2	305,6
Input current	A	178	197	214	261	277	304	316	378,0	394,2	427,4	501,6	522,4	555,0
COP (EN14511) <sup>(1)</sup>	W/W	4,19	4,09	4,18	4,18	4,17	4,06	3,31	4,04	4,09	4,15	4,16	4,14	4,14
SCOP	W/W	3,90	3,80	4,10	3,90	4,00	3,80	-	-	-	-	-	-	-
η <sub>s,h</sub> <sup>(2)</sup>	%	153	149	161	153	157	149	-	-	-	-	-	-	-
Cooling capacity (EN14511) <sup>(3)</sup>	kW	341	379	425	509	548	591	662	700,2	765,6	852,4	951,2	1001,6	1114,0
Total input power (EN14511) <sup>(3)</sup>	kW	113,0	131,0	143,0	171,0	189,0	206,0	220,0	233,9	260,4	288,4	322,4	341,0	376,0
Input current	A	197	227	249	297	325	353	365	395,2	451,2	496,8	554,3	594,4	648,0
EER	W/W	3,02	2,89	2,97	2,98	2,90	2,87	3,01	2,99	2,94	2,96	2,95	2,94	2,96
Cooling capacity (EN14511) <sup>(4)</sup>	kW	365	414	460	553	605	647	700	763,2	837,0	933,2	1036,8	1112,2	1219,0
Heating capacity (EN14511) <sup>(4)</sup>	kW	451	513	570	683	746	802	869	957,1	1036,4	1153,8	1287,0	1373,4	1502,0
Total input power (EN14511) <sup>(4)</sup>	kW	89,0	102,0	113,0	135,0	146,0	161,0	176,0	195,8	205,2	227,6	252,7	270,6	293,8
Input current	A	152	174	191	230	248	270	293	332,0	348,0	383,4	428,5	460,6	497,2
TER	W/W	9,17	9,09	9,12	9,16	9,25	9,00	8,91	8,79	9,13	9,17	9,20	9,19	9,26
Sound power <sup>(5)</sup>	dB(A)	90	92	94	92	94	94	96	93,0	93,0	96,0	95,0	95,0	96,0
Sound pressure <sup>(6)</sup>	dB(A)	58	59	62	60	62	62	63	60,0	60,0	63,0	62,0	62,0	63,0
Power supply	V/ph/Hz	400/3/50												
Circuits	n°	2	2	2	2	2	2	2	4	4	4	4	4	4
Compressors	n°	4	4	4	6	6	6	6	8	8	8	12	12	12
Fans	n°	8	8	8	10	10	12	12	16	16	16	20	20	20
Refrigerant		R410A	R410A	R410A	R410A	R410A	R410A	R410A	R410A	R410A	R410A	R410A	R410A	R410A
Refrigerant charge	kg	128	132	172	214	212	188	260	253	258	298	285	326	332
Global warming potential	GWP	2088	2088	2088	2088	2088	2088	2088	2088	2088	2088	2088	2088	2088
Equivalent CO <sub>2</sub> charge	t	267,3	275,6	359,1	446,8	442,7	392,5	542,9	528	539	622	594	682	692
Frame		5	5	5	6	6	7	7	9	9	9	10	10	10
Transport weight	kg	3245	3324	3814	4465	4532	4775	5298	7703	7780	8107	9039	9427	9521
Operating weight	kg	3264	3358	3850	4512	4581	4825	5357	7807	7915	8271	9181	9603	9771

Performances are referred to the following conditions:

(1) Heating: Ambient temperature 7°C DB, 6°C WB, water temperature 30/35°C.

(2) Average conditions, low temperature, variable - Reg EU 811/2013

(3) Cooling: ambient air temperature 35°C, evaporator water temperature in/out 12/7 °C

(4) Cooling during heating : Outdoor air 7°C.

(4) Sound power level in accordance with ISO 3744.

(5) Sound pressure level at 10 mt from the unit in free field conditions in accordance with ISO 3744.

GPE N U Kc		601	801	1001	1201	1401	1601	1801	1802	2002	2101	2302	2502	2802
Heating capacity (EN14511) <sup>(1)</sup>	kW	79,5	105,0	125,0	156,0	181,0	204,0	231,0	229,0	252,0	255,0	286	303	359
Total input power (EN14511) <sup>(1)</sup>	kW	18,3	24,5	29,0	35,8	40,2	46,5	52,8	50,9	55,5	58,1	63,1	72,3	81,5
Input current	A	37,0	44,1	55,1	66,4	72,2	83,7	94,6	99,1	104,0	103,0	117	134	150
COP (EN14511) <sup>(1)</sup>	W/W	4,34	4,29	4,31	4,36	4,50	4,39	4,38	4,50	4,54	4,39	4,53	4,19	4,40
SCOP	W/W	3,80	3,80	3,80	3,80	4,10	4,00	3,90	4,00	4,20	3,90	4,20	4,00	4,10
η <sub>s,h</sub> <sup>(2)</sup>	%	149	149	149	149	161	157	153	157	165	153	165	157	161
Cooling capacity (EN14511) <sup>(3)</sup>	kW	68,6	91,3	102,0	129,0	146,0	164,0	190,0	189,0	205,0	209,0	235	254	300
Total input power (EN14511) <sup>(3)</sup>	kW	22,3	30,9	35,1	42,7	49,7	59,0	64,1	59,5	67,2	72,4	76,4	87,5	99,2
Input current	A	41,6	50,6	62,9	74,8	86,8	99,8	109,0	109,0	118,0	122,0	133	152	170
EER	W/W	3,08	2,95	2,91	3,02	2,94	2,78	2,96	3,18	3,05	2,89	3,08	2,90	3,02
Cooling capacity (EN14511) <sup>(4)</sup>	kW	74,7	94,0	112,0	139,0	161,0	185,0	207,0	199,0	223,0	233,0	256	279	325
Heating capacity (EN14511) <sup>(4)</sup>	kW	90,9	115,0	139,0	171,0	197,0	229,0	256,0	244,0	272,0	287,0	313	343	400
Total input power (EN14511) <sup>(4)</sup>	kW	16,3	21,6	27,3	32,9	37,7	44,4	49,8	46,2	50,6	55,6	58,3	65,8	76,1
Input current	A	31,7	38,8	49,6	58,1	66,0	76,2	84,6	86,1	90,4	93,9	104	117	134
TER	W/W	10,2	9,68	9,19	9,42	9,50	9,32	9,30	9,59	9,78	9,35	9,76	9,45	9,53
Sound power <sup>(5)</sup>	dB(A)	80	82	82	84	85	86	86	83	84	87	84	84	85
Sound pressure <sup>(6)</sup>	dB(A)	49	50	50	51	53	53	53	50	52	55	52	52	52
Power supply	V/ph/Hz	400/3/50												
Circuits	n°	1	1	1	1	1	1	1	2	2	1	2	2	2
Compressors	n°	2	2	2	2	2	2	2	4	4	2	4	4	4
Fans	n°	2	2	2	3	3	3	4	6	6	4	6	8	8
Refrigerant		R410A	R410A	R410A	R410A	R410A	R410A	R410A	R410A	R410A	R410A	R410A	R410A	R410A
Refrigerant charge	kg	22	34	45	52	67	67	68	90	90	90	124	84	126
Global warming potential	GWP	2088	2088	2088	2088	2088	2088	2088	2088	2088	2088	2088	2088	2088
Equivalent CO <sub>2</sub> charge	t	45,9	71,0	94,0	108,6	139,9	139,9	142,0	187,9	187,9	187,9	258,9	175,4	263,1
Frame		1	1	1	2	2	2	3	4	4	3	4	5	5
Transport weight	kg	1039	1122	1205	1393	1559	1575	1846	1928	2155	1912	2192	2630	2852
Operating weight	kg	1045	1129	1211	1400	1567	1584	1857	1940	2167	1924	2208	2646	2870

GPE N U Kc		3202	3602	4202	4802	5202	5602	6002	7004	7504	8504	9504	10004	11004
Heating capacity (EN14511) <sup>(1)</sup>	kW	411	451	521	604	630	698	743	813,1	879,4	1003,0	1112,0	1171,4	1259,8
Total input power (EN14511) <sup>(1)</sup>	kW	93,2	105,0	118,0	140,0	150,0	164,0	171,0	194,1	210,8	235,4	265,4	280,6	301,8
Input current	A	168	187	208	252	268	289	298	352,0	373,2	416,6	501,6	503,6	536,2
COP (EN14511) <sup>(1)</sup>	W/W	4,41	4,30	4,42	4,31	4,20	4,26	4,35	4,19	4,17	4,26	4,19	4,17	4,17
SCOP	W/W	4,10	4,00	4,10	4,00	4,10	4,00	-	-	-	-	-	-	-
η <sub>s,h</sub> <sup>(2)</sup>	%	161	157	161	157	161	157	-	-	-	-	-	-	-
Cooling capacity (EN14511) <sup>(3)</sup>	kW	351	400	441	528	537	609	660	700,0	760,0	865,0	953,0	1011,0	1127,2
Total input power (EN14511) <sup>(3)</sup>	kW	113,0	130,0	147,0	175,0	191,0	208,0	220,0	234,9	258,2	289,6	323,1	343,4	379,4
Input current	A	193	221	246	294	323	347	360	407,0	440,4	491,2	554,3	587,2	646,8
EER	W/W	3,11	3,08	3,00	3,02	2,81	2,93	3,00	2,98	2,94	2,99	2,95	2,94	2,97
Cooling capacity (EN14511) <sup>(4)</sup>	kW	364	414	460	553	605	647	699	763,2	837,0	933,2	1036,8	1112,2	1219,0
Heating capacity (EN14511) <sup>(4)</sup>	kW	450	513	570	683	746	802	868	957,1	1036,4	1153,8	1287,0	1373,4	1502,0
Total input power (EN14511) <sup>(4)</sup>	kW	89,0	102,0	113,0	135,0	146,0	161,0	176,0	195,8	205,2	227,6	252,7	270,6	293,8
Input current	A	152	174	191	230	248	270	292	332,0	348,0	383,4	428,5	460,6	497,2
TER	W/W	9,15	9,09	9,12	9,16	9,25	9,00	8,90	8,79	9,13	9,17	9,20	9,19	9,26
Sound power <sup>(5)</sup>	dB(A)	84	86	88	86	88	88	90	89,0	90,0	93,0	94,0	91,0	93,0
Sound pressure <sup>(6)</sup>	dB(A)	52	53	56	53	56	56	57	55,0	56,0	60,0	61,0	57,0	60,0
Power supply	V/ph/Hz	400/3/50												
Circuits	n°	2	2	2	2	2	2	2	4	4	4	4	4	4
Compressors	n°	4	4	4	6	6	6	6	8	8	12	12	12	12
Fans	n°	8	8	10	12	12	12	14	16	16	20	24	24	24
Refrigerant		R410A	R410A	R410A	R410A	R410A	R410A	R410A	R410A	R410A	R410A	R410A	R410A	R410A
Refrigerant charge	kg	170	174	156	196	192	254	232	258	298	327	403	477	482
Global warming potential	GWP	2088	2088	2088	2088	2088	2088	2088	2088	2088	2088	2088	2088	2088
Equivalent CO <sub>2</sub> charge	t	35,0	36,3	32,7	40,2	40,9	53,0	48,4	53,9	62,1	68,2	84,1	99,7	100,7
Frame		5	5	6	7	7	7	8	9	9	10	11	11	11
Transport weight	kg	3323	3401	3816	4463	4529	4879	5285	7397	7476	8393	9718	9874	9947
Operating weight	kg	3342	3435	3852	4509	4579	1928	5344	7477	7576	8513	9838	10014	10127

Performances are referred to the following conditions:

- (1) Heating: Ambient temperature 7°C DB, 6°C WB, water temperature 30/35°C.  
(2) Average conditions, low temperature, variable - Reg EU 811/2013  
(3) Cooling: ambient air temperature 35°C, evaporator water temperature in/out 12/7 °C

(4) Cooling during heating : Outdoor air 7°C.

(5) Sound power level in accordance with ISO 3744.

(6) Sound pressure level at 10 mt from the unit in free field conditions in accordance with ISO 3744.

GPE N HE U Kc		1001	1201	1401	1601	1802	2002	2302	2502	2802	3202	3602
Heating capacity (EN14511) <sup>(1)</sup>	kW	126	155	180	205	220	249	276	308	345	387	461
Total input power (EN14511) <sup>(1)</sup>	kW	33,8	40,7	46,7	52,9	55,9	62,6	71,5	79,6	92,4	106,0	100,0
Input current	A	53,4	62,1	70,9	79,9	90,2	95,8	109,0	123,0	140	158	177
COP (EN14511) <sup>(1)</sup>	W/W	3,73	3,81	3,85	3,88	3,94	3,98	3,86	3,87	3,73	3,65	4,61
SCOP	W/W	4,00	4,20	4,30	4,30	4,50	4,70	6,00	4,60	4,60	4,40	4,60
$\eta_{s,h}$ <sup>(2)</sup>	%	157	165	169	169	177	185	237	181	181	173	181
Cooling capacity (EN14511) <sup>(3)</sup>	kW	109	134	156	184	194	216	235	268	300	339	382
Total input power (EN14511) <sup>(3)</sup>	kW	32,9	40,8	46,6	54,5	57,7	63,4	73,7	80,5	96,2	108,0	124,0
Input current	A	59,7	71,1	80,8	93,3	105,0	113,0	128,0	141,0	164	187	210
EER	W/W	3,31	3,28	3,35	3,38	3,36	3,41	3,19	3,33	3,12	3,14	3,08
Cooling capacity (EN14511) <sup>(4)</sup>	kW	114	143	164	198	210	233	256	286	330	367	419
Heating capacity (EN14511) <sup>(4)</sup>	kW	140	175	201	241	255	282	313	350	405	453	516
Total input power (EN14511) <sup>(4)</sup>	kW	27,2	32,7	37,6	43,6	45,5	50,7	58,3	64,2	76,0	87,8	99,9
Input current	A	49,7	58,1	66,1	75,5	85,4	90,7	104,0	116,0	134	152	171
TER	W/W	9,34	9,72	9,71	10,10	10,20	10,20	9,76	9,91	9,67	9,34	9,36
Sound power <sup>(5)</sup>	dB(A)	80	82	82	83	82	84	84	84	85	84	86
Sound pressure <sup>(6)</sup>	dB(A)	48	49	50	50	49	52	52	52	52	52	53
Power supply	V/ph/Hz	400/3/50										
Circuits	n°	1	1	1	1	2	2	2	2	2	2	2
Compressors	n°	2	2	2	2	4	4	4	4	4	4	4
Fans	n°	3	3	4	4	6	6	6	8	8	8	10
Refrigerant		R410A	R410A	R410A	R410A	R410A	R410A	R410A	R410A	R410A	R410A	R410A
Refrigerant charge	kg	51	67	68	90	92	124	124	126	130	180	158
Global warming potential	GWP	2088	2088	2088	2088	2088	2088	2088	2088	2088	2088	2088
Equivalent CO <sub>2</sub> charge	t	106,5	139,9	142,0	187,9	192,1	258,9	258,9	263,1	271,4	375,8	329,9
Frame		2	2	3	3	4	4	4	5	5	5	6
Transport weight	kg	1401	1547	1755	1936	2320	2570	2571	3015	3198	3713	3862
Operating weight	kg	1410	1558	1766	1952	2337	2588	2588	3033	3220	3738	3896

GPE N HE U Kc		4202	4802	5202	5602	6002	7004	7504	8504	9504	10004	
Heating capacity (EN14511) <sup>(1)</sup>	kW	493	594	638	687	728	810,0	921,4	985,2	1102,0	1185,2	
Total input power (EN14511) <sup>(1)</sup>	kW	117,0	132,0	146,0	157,0	170,0	183,1	200,4	234,2	244,9	264,8	
Input current	A	195	236	258	276	305	322,8	353,2	388,0	431,6	470,0	
COP (EN14511) <sup>(1)</sup>	W/W	4,21	4,50	4,37	4,38	4,28	4,42	4,60	4,21	4,50	4,48	
SCOP	W/W	4,70	4,50	-	-	-	-	-	-	-	-	
$\eta_{s,h}$ <sup>(2)</sup>	%	185	177	-	-	-	-	-	-	-	-	
Cooling capacity (EN14511) <sup>(3)</sup>	kW	431	517	563	609	645	702,0	754,0	853,8	950,0	1011,0	
Total input power (EN14511) <sup>(3)</sup>	kW	144,0	163,0	180,0	195,0	212,0	227,9	247,8	279,6	310,5	330,4	
Input current	A	235	279	304	330	354	389,0	423,2	472,4	554,3	563,0	
EER	W/W	2,99	3,17	3,13	3,12	3,04	3,08	3,04	3,05	3,06	3,06	
Cooling capacity (EN14511) <sup>(4)</sup>	kW	477	562	610	661	704	781,4	847,8	959,4	1051,6	1130,8	
Heating capacity (EN14511) <sup>(4)</sup>	kW	586	690	753	815	871	953,4	1043,2	1176,8	1285,0	1387,8	
Total input power (EN14511) <sup>(4)</sup>	kW	111,0	133,0	147,0	160,0	174,0	184,0	200,8	222,8	247,4	265,6	
Input current	A	189	227	250	269	290	315,3	342,6	379,0	424,0	455,2	
TER	W/W	9,58	9,41	9,27	9,22	9,05	9,43	9,42	9,59	9,45	9,48	
Sound power <sup>(5)</sup>	dB(A)	88	86	88	88	92	89	90	93	91	91	
Sound pressure <sup>(6)</sup>	dB(A)	56	54	56	56	60	56	57	60	58	58	
Power supply	V/ph/Hz	400/3/50										
Circuits	n°	2	2	2	2	2	4	4	4	4	4	
Compressors	n°	4	6	6	6	6	8	8	8	12	12	
Fans	n°	10	12	14	14	14	16	20	20	24	24	
Refrigerant		R410A	R410A	R410A	R410A	R410A	R410A	R410A	R410A	R410A	R410A	
Refrigerant charge	kg	204	256	232	304	304	299	285	328	405	479	
Global warming potential	GWP	2088	2088	2088	2088	2088	2088	2088	2088	2088	2088	
Equivalent CO <sub>2</sub> charge	t	426,0	534,5	484,4	634,8	634,8	624	596	684	845	1000	
Frame		6	7	8	8	8	9	10	10	11	1	
Transport weight	kg	4271	4927	5050	5576	5607	7620	8012	8665	9453	10086	
Operating weight	kg	4311	4976	5108	5635	5666	7755	8159	8797	9610	10263	

Performances are referred to the following conditions:

- (1) Heating: Ambient temperature 7°C DB, 6°C WB, water temperature 30/35°C.  
(2) Average conditions, low temperature, variable - Reg EU 811/2013  
(3) Cooling: ambient air temperature 35°C, evaporator water temperature in/out 12/7 °C

(4) Sound power level in accordance with ISO 3744.

(5) Sound pressure level at 10 mt from the unit in free field conditions in accordance with ISO 3744.

GPE N Kr		601	801	1001	1201	1401	1601	1801	1802	2002	2101	2302	2502	2802
Heating capacity (EN14511) <sup>(1)</sup>	kW	73,2	90,9	119,0	146,0	170,0	191,0	211,0	214,0	246,0	240,0	272,0	297,0	327,0
Total input power (EN14511) <sup>(1)</sup>	kW	18,3	22,5	28,7	35,6	41,4	47,3	51,1	53,7	60,9	58,6	66,1	71,8	82,8
Input current	A	39,2	47,7	58,0	68,8	77,7	91,1	95,0	106,0	115,0	112,0	126,0	138,0	153,0
COP (EN14511) <sup>(1)</sup>	W/W	4,00	4,04	4,15	4,10	4,11	4,04	4,13	3,99	4,04	4,10	4,11	4,14	3,95
Cooling capacity (EN14511) <sup>(2)</sup>	kW	63,8	77,2	103,0	127,0	145,0	165,0	189,0	186,0	218,0	217,0	241,0	262,0	292,0
Total input power (EN14511) <sup>(2)</sup>	kW	21,0	26,6	34,0	41,6	47,8	54,5	59,5	61,4	67,4	65,7	74,9	82,1	97,1
Input current	A	41,2	51,7	63,0	74,5	83,9	98,4	104,0	113,0	120,0	119,0	134,0	147,0	168,0
EER	W/W	3,04	2,90	3,03	3,05	3,03	3,03	3,18	3,03	3,23	3,30	3,22	3,19	3,01
Cooling capacity (EN14511) <sup>(3)</sup>	kW	68,1	82,4	112,0	136,0	154,0	177,0	201,0	197,0	229,0	227,0	253,0	277,0	313,0
Heating capacity (EN14511) <sup>(3)</sup>	kW	83,1	101,0	137,0	168,0	190,0	219,0	247,0	244,0	282,0	278,0	312,0	341,0	386,0
Total input power (EN14511) <sup>(3)</sup>	kW	15,2	19,3	25,8	33,0	36,9	42,7	46,1	47,0	54,2	52,1	59,7	66,0	74,7
Input current	A	29,2	37,9	47,9	58,4	62,6	76,5	80,4	86,9	95,6	93,1	107,0	118,0	128,0
TER	W/W	9,95	9,50	9,65	9,21	9,32	9,27	9,72	9,38	9,43	9,69	9,46	9,36	9,36
Sound power <sup>(4)</sup>	dB(A)	83	86	86	88	89	90	90	88	90	91	90	90	91
Sound pressure <sup>(5)</sup>	dB(A)	51	54	54	56	57	58	58	56	58	59	58	58	58
Power supply	V/ph/Hz	400/3/50												
Circuits	n°	1	1	1	1	1	1	1	2	2	1	2	2	2
Compressors	n°	2	2	2	2	2	2	2	4	4	2	4	4	4
Fans	n°	2	2	2	2	3	3	3	6	6	4	6	6	8
Refrigerant		R454B	R454B	R454B	R454B	R454B	R454B	R454B	R454B	R454B	R454B	R454B	R454B	R454B
Refrigerant charge	kg	22	22	34	45	50	50	67	66	96	68	94	94	88
Global warming potential	GWP	466	466	466	466	466	466	466	466	466	466	466	466	466
Equivalent CO <sub>2</sub> charge	t	10	10	16	21	23	23	31	31	45	32	44	44	41
Frame		1	1	1	1	2	2	2	4	4	3	4	4	5
Transport weight	kg	1017	1086	1169	1363	1517	1532	1824	1906	2183	1818	2131	2616	2776
Operating weight	kg	1023	1092	1176	1371	1525	1541	1835	1918	2195	1830	2147	2633	2793

GPE N Kr		3202	3602	4202	4802	5202	5602	6002	7004	7504	8504	9504	10004	11004
Heating capacity (EN14511) <sup>(1)</sup>	kW	374,0	420,0	470,0	555,0	569,0	653,0	708,0	782,4	846,1	939,9	1036,9	1113,2	1192,2
Total input power (EN14511) <sup>(1)</sup>	kW	91,7	103,0	113,0	135,0	146,0	158,0	172,0	190,4	202,8	221,2	249,6	267,1	285,2
Input current	A	163,0	188,0	211,0	238,0	262,0	291,0	149,0	346,6	369,1	402,6	454,2	486,1	519,1
COP (EN14511) <sup>(1)</sup>	W/W	4,08	4,08	4,16	4,11	4,08	4,13	4,12	4,11	4,17	4,25	4,15	4,17	4,18
Cooling capacity (EN14511) <sup>(2)</sup>	kW	336,0	375,0	421,0	497,0	537,0	582,0	642,0	690,9	754,5	840,0	923,5	972,4	1081,6
Total input power (EN14511) <sup>(2)</sup>	kW	104,0	118,0	128,0	153,0	168,0	185,0	197,0	219,0	244,7	271,1	305,1	321,3	352,8
Input current	A	175,0	205,0	228,0	258,0	288,0	323,0	341,0	392,6	424,0	467,0	524,5	560,0	608,0
EER	W/W	3,23	3,18	3,29	3,25	3,20	3,15	3,26	3,15	3,08	3,10	3,03	3,03	3,07
Cooling capacity (EN14511) <sup>(3)</sup>	kW	349,0	395,0	441,0	518,0	567,0	621,0	666,0	719,4	789,0	879,6	977,3	1048,4	1149,0
Heating capacity (EN14511) <sup>(3)</sup>	kW	431,0	488,0	543,0	640,0	699,0	764,0	820,0	886,4	963,6	1073,3	1192,3	1278,6	1398,9
Total input power (EN14511) <sup>(3)</sup>	kW	83,7	96,4	106,0	125,0	137,0	147,0	160,0	175,9	184,4	204,5	227,0	243,1	264,0
Input current	A	138,0	164,0	186,0	206,0	231,0	254,0	280,0	322,6	338,1	375,0	416,3	445,8	484,1
TER	W/W	9,32	9,16	9,28	9,26	9,24	9,42	9,29	9,13	9,51	9,55	9,56	9,57	9,65
Sound power <sup>(4)</sup>	dB(A)	90	92	94	92	94	94	96	95	95	97	98	98	98
Sound pressure <sup>(5)</sup>	dB(A)	58	59	62	60	62	62	63	62	62	65	65	65	65
Power supply	V/ph/Hz	400/3/50												
Circuits	n°	2	2	2	2	2	2	2	4	4	4	4	4	4
Compressors	n°	4	4	4	6	6	6	6	8	8	8	12	12	12
Fans	n°	8	8	8	10	10	12	12	16	16	16	20	20	20
Refrigerant		R454B	R454B	R454B	R454B	R454B	R454B	R454B	R454B	R454B	R454B	R454B	R454B	R454B
Refrigerant charge	kg	138	138	172	212	212	192	256	253	258	298	285	326	332
Global warming potential	GWP	466	466	466	466	466	466	466	466	466	466	466	466	466
Equivalent CO <sub>2</sub> charge	t	64	64	80	99	99	89	119	118	120	139	133	152	154
Frame		5	5	5	6	6	7	7	9	9	9	10	10	10
Transport weight	kg	3245	3324	3814	4465	4532	4775	5298	7836	7914	8247	9195	9589	9685
Operating weight	kg	3264	3358	3850	4512	4581	4825	5357	7876	7974	8339	9251	9671	9835

Performances are referred to the following conditions:

- (1) Heating: Ambient temperature 7°C DB, 6°C WB, water temperature 30/35°C.
- (2) Cooling: ambient air temperature 35°C, evaporator water temperature in/out 12/7 °C

(3) Cooling during heating : Outdoor air 7°C.

(4) Sound power level in accordance with ISO 3744.

(5) Sound pressure level at 10 mt from the unit in free field conditions in accordance with ISO 3744.

GPE N U Kr		601	801	1001	1201	1401	1601	1801	1802	2002	2101	2302	2502	2802
Heating capacity (EN14511) <sup>(1)</sup>	kW	72,7	92,0	115,0	149,0	166,0	190,0	213,0	212,0	242,0	236,0	263	291	332
Total input power (EN14511) <sup>(1)</sup>	kW	17,2	21,3	27,5	35,5	39,5	45,4	50,3	51,0	57,9	55,9	63,1	70,4	79,1
Input current	A	35,0	43,7	53,9	67,3	71,4	84,9	91,4	98,0	107,0	104,0	118	134	143
COP (EN14511) <sup>(1)</sup>	W/W	4,23	4,32	4,18	4,20	4,20	4,19	4,23	4,16	4,18	4,22	4,17	4,13	4,20
Cooling capacity (EN14511) <sup>(2)</sup>	kW	63,1	79,4	104,0	128,0	145,0	166,0	191,0	189,0	216,0	213,0	240	257	296
Total input power (EN14511) <sup>(2)</sup>	kW	20,2	24,5	32,4	40,7	45,6	52,6	57,4	56,9	66,6	64,8	72,3	83,2	90,9
Input current	A	37,9	46,8	58,9	72,1	78,0	92,9	99,3	104,0	116,0	114,0	127	146	156
EER	W/W	3,12	3,24	3,21	3,14	3,18	3,16	3,33	3,32	3,24	3,29	3,32	3,09	3,26
Cooling capacity (EN14511) <sup>(3)</sup>	kW	66,8	82,6	112,0	136,0	154,0	177,0	201,0	197,0	229,0	227,0	253	277	312
Heating capacity (EN14511) <sup>(3)</sup>	kW	81,4	101,0	137,0	168,0	190,0	219,0	247,0	243,0	282,0	278,0	312	341	385
Total input power (EN14511) <sup>(3)</sup>	kW	14,8	19,3	25,8	33,0	36,9	42,7	46,1	47,0	54,2	52,1	59,7	66,0	74,7
Input current	A	29,2	37,9	47,9	58,4	62,6	76,5	80,4	86,9	95,6	93,1	107	118	128
TER	W/W	10,0	9,51	9,65	9,21	9,32	9,27	9,72	9,36	9,43	9,69	9,46	9,36	9,33
Sound power <sup>(4)</sup>	dB(A)	80	82	82	84	85	86	86	83	84	87	84	84	85
Sound pressure <sup>(5)</sup>	dB(A)	49	50	50	51	53	53	53	50	52	55	52	52	52
Power supply	V/ph/Hz	400/3/50												
Circuits	n°	1	1	1	1	1	1	1	2	2	1	2	2	2
Compressors	n°	2	2	2	2	2	2	2	4	4	2	4	4	4
Fans	n°	2	2	2	2	3	3	3	6	6	4	6	8	8
Refrigerant		R454B	R454B	R454B	R454B	R454B	R454B	R454B	R454B	R454B	R454B	R454B	R454B	R454B
Refrigerant charge	kg	22	33	45	51	67	67	67	94	124	122	122	128	128
Global warming potential	GWP	466	466	466	466	466	466	466	466	466	466	466	466	466
Equivalent CO <sub>2</sub> charge	t	10	15	21	24	31	31	31	44	58	57	57	60	60
Frame		1	1	1	1	2	2	2	4	4	3	4	5	5
Transport weight	kg	1039	1112	1205	1393	1559	1575	1846	1928	2155	1912	2192	2630	2852
Operating weight	kg	1045	1129	1211	1400	1567	1584	1857	1940	2167	1924	2208	2646	2870

GPE N U Kr		3202	3602	4202	4802	5202	5602	6002	7004	7504	8504	9504	10004	11004
Heating capacity (EN14511) <sup>(1)</sup>	kW	363	409	467	547	586	641	692	759,0	820,9	936,3	1038,1	1093,5	1176,1
Total input power (EN14511) <sup>(1)</sup>	kW	87,8	99,1	110,0	131,0	142,0	152,0	161,0	182,0	196,8	220,4	248,6	263,0	280,6
Input current	A	152	177	204	227	251	274	295	331,2	358,2	401,2	452,5	478,7	510,7
COP (EN14511) <sup>(1)</sup>	W/W	4,13	4,13	4,25	4,18	4,13	4,22	4,30	4,17	4,17	4,25	4,18	4,16	4,19
Cooling capacity (EN14511) <sup>(2)</sup>	kW	333	373	419	483	522	578	624	683,1	741,6	844,1	920,8	976,8	1089,1
Total input power (EN14511) <sup>(2)</sup>	kW	101,0	116,0	131,0	156,0	171,0	181,0	192,0	226,2	246,2	274,9	307,1	326,2	361,7
Input current	A	168	197	228	258	289	312	334	391,9	419,9	466,3	526,9	557,7	616,6
EER	W/W	3,30	3,22	3,20	3,10	3,05	3,19	3,25	3,02	3,01	3,07	3,00	2,99	3,01
Cooling capacity (EN14511) <sup>(3)</sup>	kW	349	395	442	517	567	621	665	719,4	789,0	879,6	977,3	1048,4	1149,0
Heating capacity (EN14511) <sup>(3)</sup>	kW	431	488	544	639	699	764	819	886,4	963,6	1073,3	1192,3	1278,6	1398,9
Total input power (EN14511) <sup>(3)</sup>	kW	83,7	96,4	106,0	125,0	137,0	147,0	160,0	175,9	184,4	204,5	227,0	243,1	264,0
Input current	A	138	164	186	206	231	254	280	322,6	338,1	375,0	416,3	445,8	484,1
TER	W/W	9,32	9,16	9,30	9,25	9,24	9,42	9,28	9,13	9,51	9,55	9,56	9,57	9,65
Sound power <sup>(4)</sup>	dB(A)	84	86	88	86	88	88	90	91	92	95	97	94	96
Sound pressure <sup>(5)</sup>	dB(A)	52	53	56	53	56	56	57	57	58	62	64	60	63
Power supply	V/ph/Hz	400/3/50												
Circuits	n°	2	2	2	2	2	2	2	4	4	4	4	4	4
Compressors	n°	4	4	4	6	6	6	6	8	8	12	12	12	12
Fans	n°	8	8	10	12	12	12	14	16	16	20	24	24	24
Refrigerant		R454B	R454B	R454B	R454B	R454B	R454B	R454B	R454B	R454B	R454B	R454B	R454B	R454B
Refrigerant charge	kg	178	158	210	252	228	296	296	255	294	322	398	471	476
Global warming potential	GWP	466	466	466	466	466	466	466	466	466	466	466	466	466
Equivalent CO <sub>2</sub> charge	t	83	74	98	117	106	138	138	119	137	150	185	220	222
Frame		5	5	6	7	7	7	8	9	9	10	11	11	11
Transport weight	kg	3323	3401	3816	4463	4529	4879	5285	7180	7535	8544	9321	9945	10013
Operating weight	kg	3342	3435	3852	4509	4579	4928	5344	7220	7585	8604	9381	10015	10103

Performances are referred to the following conditions:

- (1) Heating: Ambient temperature 7°C DB, 6°C WB, water temperature 30/35°C.
- (2) Cooling: ambient air temperature 35°C, evaporator water temperature in/out 12/7 °C

(3) Cooling during heating : Outdoor air 7°C.

(4) Sound power level in accordance with ISO 3744.

(5) Sound pressure level at 10 mt from the unit in free field conditions in accordance with ISO 3744.

GPE N HE Kr		1001	1201	1401	1601	1802	2002	2302	2502	2802	3202	3602
Heating capacity (EN14511) <sup>(1)</sup>	kW	124	145	174	200	218	248	274	304	340	375	434
Total input power (EN14511) <sup>(1)</sup>	kW	29,8	35,4	41,8	47,7	53,6	61,1	66,5	74,2	83,2	92,4	104,0
Input current	A	56,3	66,9	74,1	87,1	100,0	110,0	121,0	137,0	146	157	183
COP (EN14511) <sup>(1)</sup>	W/W	4,16	4,10	4,16	4,19	4,07	4,06	4,12	4,10	4,09	4,06	4,17
Cooling capacity (EN14511) <sup>(2)</sup>	kW	108	134	153	175	193	225	246	272	302	341	382
Total input power (EN14511) <sup>(2)</sup>	kW	31,6	38,9	43,3	49,8	56,5	63,9	71,3	78,0	90,4	98,9	115,0
Input current	A	57,9	69,1	75,3	88,9	103,0	112,0	126,0	139,0	155	164	196
EER	W/W	3,42	3,44	3,53	3,51	3,42	3,52	3,45	3,49	3,34	3,45	3,32
Cooling capacity (EN14511) <sup>(3)</sup>	kW	112	139	157	179	197	229	253	277	312	349	397
Heating capacity (EN14511) <sup>(3)</sup>	kW	137	170	192	221	243	282	312	341	385	430	488
Total input power (EN14511) <sup>(3)</sup>	kW	25,8	32,0	35,9	41,8	47,0	54,2	59,7	66,0	74,7	83,7	93,3
Input current	A	47,9	57,6	63,0	75,6	86,9	95,6	107,0	118,0	128	138	161
TER	W/W	9,65	9,66	9,72	9,57	9,36	9,43	9,46	9,36	9,33	9,31	9,49
Sound power <sup>(4)</sup>	dB(A)	84	87	87	87	89	91	91	91	91	91	92
Sound pressure <sup>(5)</sup>	dB(A)	52	55	55	55	57	58	58	59	59	58	60
Power supply	V/ph/Hz	400/3/50										
Circuits	n°	1	1	1	1	2	2	2	2	2	2	2
Compressors	n°	2	2	2	2	4	4	4	4	4	4	4
Fans	n°	3	3	4	4	6	6	6	8	8	8	10
Refrigerant		R454B	R454B	R454B	R454B	R454B	R454B	R454B	R454B	R454B	R454B	R454B
Refrigerant charge	kg	51	67	67	89	96	126	126	132	132	182	158
Global warming potential	GWP	466	466	466	466	466	466	466	466	466	466	466
Equivalent CO <sub>2</sub> charge	t	24	31	31	41	45	59	59	62	62	85	74
Frame		2	2	3	3	4	4	4	5	5	5	6
Transport weight	kg	1379	1525	1733	1733	2298	2548	2549	2933	3176	3691	3840
Operating weight	kg	1388	1536	1744	1744	2312	2566	2566	3100	3198	3716	3874

GPE N HE Kr		4202	4802	5202	5602	6002	7004	7504	8504	9504	10004	
Heating capacity (EN14511) <sup>(1)</sup>	kW	488	565	622	675	723	761,7	868,8	973,0	1066,3	1127,6	
Total input power (EN14511) <sup>(1)</sup>	kW	116,0	138,0	151,0	162,0	174,0	192,1	216,7	237,2	269,4	282,2	
Input current	A	210	234	262	286	312	349,6	394,5	431,7	490,3	513,6	
COP (EN14511) <sup>(1)</sup>	W/W	4,21	4,09	4,12	4,17	4,16	3,97	4,01	4,10	3,96	4,00	
Cooling capacity (EN14511) <sup>(2)</sup>	kW	443	506	557	605	647	704,0	762,0	867,6	956,0	1033,6	
Total input power (EN14511) <sup>(2)</sup>	kW	125,0	148,0	166,0	175,0	189,0	220,6	247,2	274,9	300,0	322,1	
Input current	A	220	246	282	302	331	372,3	417,6	462,5	532,3	543,1	
EER	W/W	3,54	3,42	3,36	3,46	3,42	3,19	3,08	3,16	3,19	3,21	
Cooling capacity (EN14511) <sup>(3)</sup>	kW	451	519	573	620	665	736,6	799,1	904,3	991,2	1065,9	
Heating capacity (EN14511) <sup>(3)</sup>	kW	554	640	705	762	819	896,0	973,2	1097,3	1205,6	1296,0	
Total input power (EN14511) <sup>(3)</sup>	kW	106,0	125,0	137,0	147,0	160,0	168,5	183,9	204,0	226,5	243,2	
Input current	A	187	206	231	254	280	303,1	330,8	367,1	407,6	437,6	
TER	W/W	9,48	9,27	9,33	9,40	9,28	9,69	9,64	9,81	9,70	9,71	
Sound power <sup>(4)</sup>	dB(A)	94	92	95	95	96	97	98	99	98	99	
Sound pressure <sup>(5)</sup>	dB(A)	62	60	62	62	63	64	65	66	65	66	
Power supply	V/ph/Hz	400/3/50										
Circuits	n°	2	2	2	2	2	4	4	4	4	4	
Compressors	n°	4	6	6	6	6	8	8	8	12	12	
Fans	n°	10	12	14	14	14	16	20	20	24	24	
Refrigerant		R454B	R454B	R454B	R454B	R454B	R454B	R454B	R454B	R454B	R454B	
Refrigerant charge	kg	216	260	234	304	304	300	315	351	491	508	
Global warming potential	GWP	466	466	466	466	466	466	466	466	466	466	
Equivalent CO <sub>2</sub> charge	t	101	121	109	142	142	140	147	164	229	237	
Frame		6	7	8	8	8	9	10	10	11	11	
Transport weight	kg	4249	4905	5028	5554	5585	7852	8258	8907	9714	10364	
Operating weight	kg	4289	4954	5086	5613	5644	7940	8358	9007	9816	10476	

Performances are referred to the following conditions:

- (1) Heating: Ambient temperature 7°C DB, 6°C WB, water temperature 30/35°C.  
(2) Cooling: ambient air temperature 35°C, evaporator water temperature in/out 12/7 °C

(3) Cooling during heating : Outdoor air 7°C.

(4) Sound power level in accordance with ISO 3744.

(5) Sound pressure level at 10 mt from the unit in free field conditions in accordance with ISO 3744.

GPE N HE U Kr		1001	1201	1401	1601	1802	2002	2302	2502	2802	3202	3602
Heating capacity (EN14511) <sup>(1)</sup>	kW	126	150	172	195	214	243	269	299	335	368	424
Total input power (EN14511) <sup>(1)</sup>	kW	27,0	33,2	38,1	43,9	49,0	56,2	61,4	68,0	76,6	85,4	98,1
Input current	A	52,3	62,6	68,6	81,5	93,2	102,0	114,0	128,0	137	146	174
COP (EN14511) <sup>(1)</sup>	W/W	4,67	4,52	4,51	4,44	4,37	4,32	4,38	4,40	4,337	4,31	4,32
Cooling capacity (EN14511) <sup>(2)</sup>	kW	107	132	151	173	189	220	240	267	297	334	374
Total input power (EN14511) <sup>(2)</sup>	kW	30,3	37,6	41,7	48,4	54,6	62,3	70,2	75,7	87,8	97,3	112,0
Input current	A	55,8	67,0	72,7	86,6	99,6	109,0	124,0	135,0	150	161	191
EER	W/W	3,53	3,51	3,62	3,57	3,46	3,53	3,42	3,53	3,38	3,43	3,34
Cooling capacity (EN14511) <sup>(3)</sup>	kW	112	139	157	179	197	229	254	277	312	349	392
Heating capacity (EN14511) <sup>(3)</sup>	kW	137	170	192	221	244	282	312	341	385	430	485
Total input power (EN14511) <sup>(3)</sup>	kW	25,8	32,0	35,9	41,8	47,0	54,2	59,7	66,0	74,7	83,7	95,9
Input current	A	47,9	57,6	63,0	75,6	86,9	95,6	107,0	118,0	128	138	164
TER	W/W	9,65	9,66	9,72	9,57	9,38	9,43	9,48	9,36	9,33	9,31	9,14
Sound power <sup>(4)</sup>	dB(A)	80	82	82	83	82	84	84	84	85	84	86
Sound pressure <sup>(5)</sup>	dB(A)	48	49	50	50	49	52	52	52	52	52	53
Power supply	V/ph/Hz	400/3/50										
Circuits	n°	1	1	1	1	2	2	2	2	2	2	2
Compressors	n°	2	2	2	2	4	4	4	4	4	4	4
Fans	n°	3	3	4	4	6	6	6	8	8	8	10
Refrigerant		R454B	R454B	R454B	R454B	R454B	R454B	R454B	R454B	R454B	R454B	R454B
Refrigerant charge	kg	50	66	66	88	94	124	122	128	128	178	158
Global warming potential	GWP	466	466	466	466	466	466	466	466	466	466	466
Equivalent CO <sub>2</sub> charge	t	23	31	31	41	44	58	57	60	60	83	74
Frame		2	2	3	3	4	4	4	5	5	5	6
Transport weight	kg	1401	1547	1755	1936	2320	2570	2571	3015	3198	3713	3862
Operating weight	kg	1410	1558	1766	1952	2337	2588	2588	3033	3220	3738	3896

GPE N HE U Kr		4202	4802	5202	5602	6002	7004	7504	8504	9504	10004	
Heating capacity (EN14511) <sup>(1)</sup>	kW	472	554	605	658	698	756,2	860,2	919,7	1028,8	1106,4	
Total input power (EN14511) <sup>(1)</sup>	kW	108,0	128,0	139,0	150,0	161,0	174,3	191,7	211,1	234,0	251,5	
Input current	A	197	219	245	269	294	317,3	348,9	384,2	426,0	457,7	
COP (EN14511) <sup>(1)</sup>	W/W	4,37	4,33	4,35	4,39	4,34	4,34	4,49	4,36	4,40	4,40	
Cooling capacity (EN14511) <sup>(2)</sup>	kW	430	496	543	594	633	702,0	754,0	853,8	950,0	1011,0	
Total input power (EN14511) <sup>(2)</sup>	kW	123,0	146,0	161,0	171,0	186,0	214,2	235,3	264,4	294,2	312,2	
Input current	A	216	242	274	296	326	365,6	401,9	446,7	525,2	531,9	
EER	W/W	3,50	3,40	3,37	3,47	3,40	3,28	3,20	3,23	3,23	3,24	
Cooling capacity (EN14511) <sup>(3)</sup>	kW	451	520	572	621	665	736,6	799,1	904,3	991,2	1065,9	
Heating capacity (EN14511) <sup>(3)</sup>	kW	554	641	704	764	819	896,0	973,2	1097,3	1205,6	1296,0	
Total input power (EN14511) <sup>(3)</sup>	kW	106,0	125,0	136,0	147,0	160,0	168,5	183,9	204,0	226,5	243,2	
Input current	A	187	206	231	254	280	303,1	330,8	367,1	407,6	437,6	
TER	W/W	9,48	9,29	9,38	9,42	9,28	9,69	9,64	9,81	9,70	9,71	
Sound power <sup>(4)</sup>	dB(A)	88	86	88	88	92	91	92	93	94	94	
Sound pressure <sup>(5)</sup>	dB(A)	56	54	56	56	60	58	59	60	61	61	
Power supply	V/ph/Hz	400/3/50										
Circuits	n°	2	2	2	2	2	4	4	4	4	4	
Compressors	n°	4	6	6	6	6	8	8	8	12	12	
Fans	n°	10	12	14	14	14	16	20	20	24	24	
Refrigerant		R454B	R454B	R454B	R454B	R454B	R454B	R454B	R454B	R454B	R454B	
Refrigerant charge	kg	210	252	228	296	296	294	281	322	398	471	
Global warming potential	GWP	466	466	466	466	466	466	466	466	466	466	
Equivalent CO <sub>2</sub> charge	t	98	117	106	138	138	137	131	150	185	220	
Frame		6	7	8	8	8	9	10	10	11	11	
Transport weight	kg	4271	4927	5050	5576	5607	7852	8258	8907	9714	10364	
Operating weight	kg	4311	4976	5108	5635	5666	7940	8358	9007	9816	10476	

Performances are referred to the following conditions:

- (1) Heating: Ambient temperature 7°C DB, 6°C WB, water temperature 30/35°C.  
(2) Cooling: ambient air temperature 35°C, evaporator water temperature in/out 12/7 °C

(3) Cooling during heating : Outdoor air 7°C.

(4) Sound power level in accordance with ISO 3744.

(5) Sound pressure level at 10 mt from the unit in free field conditions in accordance with ISO 3744.

## COMPONENTS

### FRAME

All units are made from hot-galvanised sheet steel, painted with polyurethane powder enamel and stoved at 180°C to provide maximum protection against corrosion. The frame is self-supporting with removable panels. All screws and rivets used are made from stainless steel. The standard colour of the units is RAL9018.

### REFRIGERANT CIRCUIT

The refrigerant circuit is assembled using internationally recognised brand name components with all brazing and welding being performed in accordance with ISO 97/23. The refrigerant utilised are R410A or R454B. The refrigerant circuit includes: sight glass, filter drier, electronic expansion valves, 4 way reversing valve, check valves, liquid receiver, liquid separator, schrader valves for maintenance and control, pressure safety device (for compliance with PED regulations).

### COMPRESSORS

The compressors are scroll type, with crankcase resistance and thermal protection, installed in a separate compartment from the airflow in order to reduce noise. When the unit is on stand-by mode, the crankcase heater is always powered. Through the unit's front panel, it is possible to inspect and repair the compressors even when the unit is running.

The compressors used are tandem type. This solution allows a significantly higher efficiency with partial loads compared to the option with independent refrigerant circuits. The control system constantly monitors the discharge temperature of the single compressors.

### SOURCE HEAT EXCHANGER

The source heat exchanger is made from 3/8" copper pipes and 0,1mm at least thick aluminium fins with the tubes being mechanically expanded into the aluminium fins in order to maximise heat transfer. Furthermore, the design guarantees a low air side pressure drop thus enabling the use of low rotation speed (and hence low noise) fans. All heat exchangers are supplied standard with fins hydrophilic coating "Blue Fins".

### COOLING OR HEATING USER CIRCUIT HEAT EXCHANGERS

The user heat exchanger is a braze welded, plate type heat exchanger, manufactured from AISI 316 stainless steel. The use of this type of exchanger results in a massive reduction of the refrigerant charge of the unit compared to a traditional shell-in-tube type. A further advantage is a reduction in the overall dimensions of the unit. The exchangers are factory insulated with flexible close cell material and can be fitted with an antifreeze heater (accessory). Each exchanger is fitted with a temperature sensor on the discharge water side for antifreeze protection.

### FANS

The fans are direct drive axial type with aerofoil blades, are statically and dynamically balanced and are supplied complete with a safety fan guard complying with the requirements of EN 60335. They are fixed to the unit frame via rubber anti-vibration mountings. The electric motors, in standard versions are 6 poles type and a phase-cut regulator or inverter that adjusts the rotation speed according to the ambient temperature. In the HE versions, the fans are electronic type, with permanent magnet motors with an integrated driver that modulates the speed of rotation. The motors are fitted with integrated thermal overload protection and have a moisture protection rating of IP 54.

### MICROPROCESSORS

All units are supplied as standard with microprocessor controls. The microprocessor controls the following functions: control of the water temperature, antifreeze protection, compressor timing, compressor automatic starting sequence (For multiple compressors), alarm reset.

The control panel is supplied with display showing all operational icons. The microprocessor is set for automatic defrost (when operating in severe ambient conditions) and for summer/ winter change over. The control also manages the integration with other heating sources (electric heaters, boilers, solar panels etc) and both the heating circuit pump and the domestic hot water circuit pump. If required (available as an option), the microprocessor can be configured in order for it to connect to a site BMS system thus enabling remote control and management.

### ELECTRIC ENCLOSURE

The enclosure is manufactured in order to comply with the requirements of the electromagnetic compatibility standards 2014/35/UE and 2014/30/UE. Access to the enclosure is achieved by removing the front panel of the unit. The following components are supplied as standard on all units: main switch, a sequence relay that disables the power supply in the event that the phase sequence is incorrect (scroll compressors can be damaged if they rotate in the wrong direction), thermal overloads (protection of pumps and fans), compressor fuses, control circuit automatic breakers, compressor contactors, fan contactors and pump contactors. The terminal board has volt free contacts for remote ON-OFF, Summer/ winter change over (heat pumps only) and general alarm.

### CONTROL AND PROTECTION DEVICES

All units are standardly equipped with several control and safety devices: water return temperature sensor, installed on the water return pipe of the system, and anti-freeze probe, installed on the water supply pipe to the system high-pressure switch with automatic reset. There are also included a low-pressure automatic reset, pressure transducer (used to optimize the defrosting cycle and modulate the rotation speed of the fans according to external conditions), Freon side safety device, compressor thermal protection, fan thermal protection, flow switch, and external air compensation probe.

### LEAK DETECTOR (Kr version only)

When the unit is powered ON, the sensor is warmed up/initialised (duration approx. 1min.).

During this period, the LEDs inside the sensor blink, the refrigerant leakage alarm is notified and the 24Vac auxiliary circuit is switched off. After this period, if in the absence of any further feedback from the sensor, the PLC control is powered up and the unit is ready to operate. If refrigerant leaks occur, the sensor is activated and the power supply to the control PLC is immediately switched off until the sensor indicates the refrigerant is still present.

## VERSION

### Ultrasilenced version (U)

The remarkably low sound level is reached on U versions without sacrificing performance or working limits.

This is done by:

- Adopting refrigerant/air exchangers with wider surfaces than those of the units in standard version.
- Soundproof compressor casing with higher thickness of the soundproof material;
- Fan speed control through variable fixed drive.

### HE Version

High efficiency version, according to current standard. Unit equipped with EC fans.

## OPERATION LIMITS

### Standard version

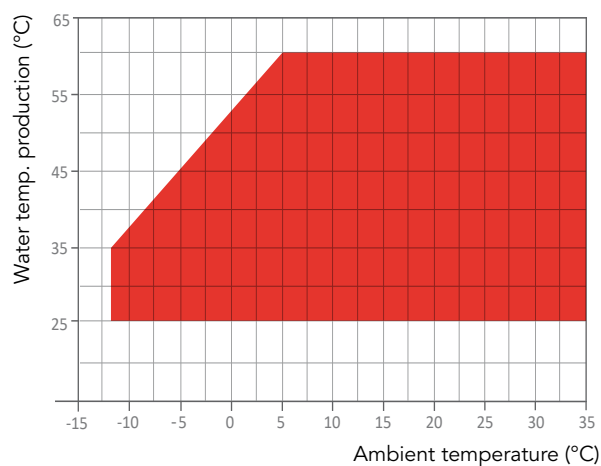
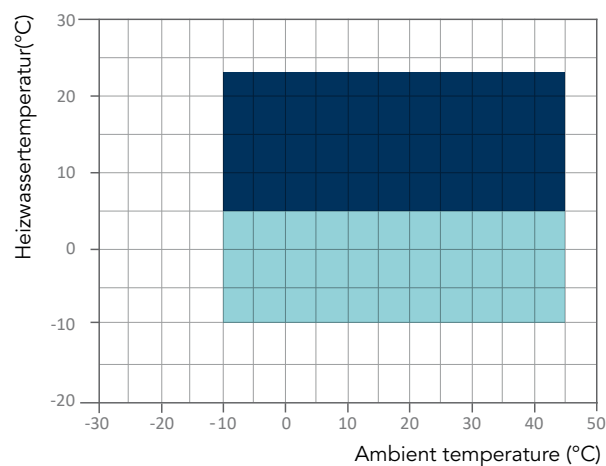

### HE version

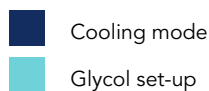
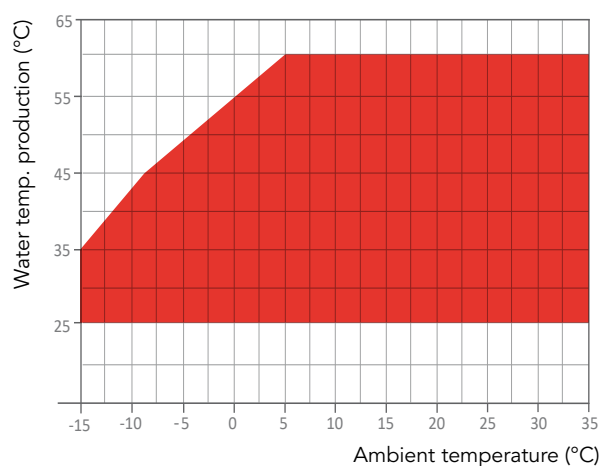
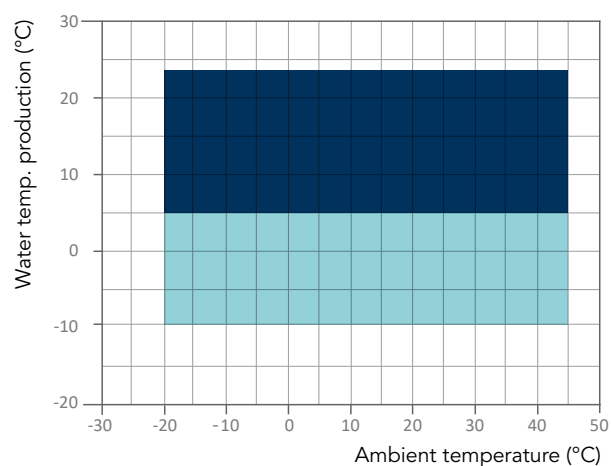

## ACCESSORIES

GPE N Kc/Kr		601÷1201	1401÷1801	1802-2002	2101	2302+2802	3602+6002	7004÷11004
Amperometer	<b>A</b>	0	0	0	0	0	0	0
Electrical power supply different than standard	<b>AE</b>	0	0	0	0	0	0	0
Coil with Electrofin treatment	<b>BEF</b>	0	0	0	0	0	0	0
Operation in cooling mode down to -20°C	<b>BF</b> <sup>(1)</sup>	0	0	0	0	0	0	0
Operation in cooling mode down to -10°C	<b>BT</b> <sup>(1)</sup>	●	●	●	●	●	●	●
Soundproofed compressors cabinet with standard material	<b>CF</b>	●	●	●	●	●	●	●
Soundproofed compressors cabinet with higher thickness material	<b>CFU</b> <sup>(2)</sup>	0	0	0	0	0	0	0
Soundproofing jacket on compressors	<b>CI</b>	0	0	0	0	0	0	0
Compressors inrush counter	<b>CS</b>	0	0	0	0	0	0	0
Refrigerant leakage detector	<b>DR</b> <sup>(3)</sup>	●	●	●	●	●	●	●
Axial fans with electronic commutated motor	<b>EC</b> <sup>(4)</sup>	0	0	0	0	0	0	0
Condensing coil protection grid	<b>GP</b>	0	0	0	0	0	0	0
Anti-intrusion grid	<b>GP2</b>	0	0	0	0	0	0	0
Anti-intrusion grid	<b>GP3</b>	0	0	0	0	0	0	0
Web application	<b>HiPro.web</b>	0	0	0	0	0	0	0
Visograph interface accessory	<b>HMI.Pro</b>	0	0	0	0	0	0	0
Victaulic insulation on pump side	<b>I1</b>	0	0	0	0	0	0	0
Victaulic insulation buffer tank side	<b>I2</b>	0	0	0	0	0	0	0
RS 485 Serial interface	<b>IH</b>	0	0	0	0	0	0	0
BAC-NET Serial interface	<b>IH BAC</b>	0	0	0	0	0	0	0
Seawood packing	<b>IM</b>	0	0	0	0	0	0	0
TCP/IP Protocol serial interface	<b>IWG</b>	0	0	0	0	0	0	0
Phase monitor	<b>MF</b>	0	0	0	0	0	0	0
Group 1 Pump Heating Circuit Variable water flow	<b>P12CVS</b>	0	0	0	0	0	0	0
Group 1 Pump Cooling Circuit Variable water flow	<b>P12FVS</b>	0	0	0	0	0	0	0
Group 1 Pump Heating Circuit low pressure	<b>P1C</b>	0	0	0	0	0	0	0
Group 1 Pump Cooling Circuit low pressure	<b>P1F</b>	0	0	0	0	0	0	0
Group 1 Pump Heating Circuit high pressure	<b>P1HC</b>	0	0	0	0	0	0	0
Group 1 Pump Cooling Circuit high pressure	<b>P1HF</b>	0	0	0	0	0	0	0
Group 2 Pumps Heating Circuit Variable water flow	<b>P22CVS</b> <sup>(5)</sup>	0	0	0	0	0	0	0
Group 2 Pumps Cooling Circuit Variable water flow	<b>P22FVS</b> <sup>(5)</sup>	0	0	0	0	0	0	0
Group 2 Pumps Heating Circuit low pressure	<b>P2C</b>	0	0	0	0	0	0	0
Group 2 Pumps Cooling Circuit low pressure	<b>P2F</b>	0	0	0	0	0	0	0
Group 2 Pumps Heating Circuit high pressure	<b>P2HC</b>	0	0	0	0	0	0	0
Group 2 Pumps Cooling Circuit high pressure	<b>P2HF</b>	0	0	0	0	0	0	0
Rubber-type vibration dampers	<b>PA</b>	0	0	0	0	0	0	0
Spring-type vibration dampers	<b>PM</b>	0	0	0	0	0	0	0
Remote display	<b>PQ</b>	0	0	0	0	0	0	0
Heating circuit In-line twin pump	<b>PTC</b>	--	0	0	0	0	0	0
Cooling circuit In-line twin pump	<b>PTF</b>	--	0	0	0	0	0	0
Anti-freeze heater on evaporator	<b>RA</b>	0	0	0	0	0	0	0
Shut-off valve on compressors discharge side	<b>RD</b>	0	0	0	0	0	0	0
Power factor correction system cosφ ≥ 0,9	<b>RF</b>	0	0	0	0	0	0	0
Shut-off valve on compressors suction side	<b>RH</b>	0	0	0	0	0	0	0
Compressor overload relays	<b>RL</b>	0	0	0	0	0	0	0
Condensing coil with pre-painted fins	<b>RM</b>	0	0	0	0	0	0	0
Copper/Copper coil	<b>RR</b>	0	0	0	0	0	0	0
Electronic thermostatic valve	<b>TE</b>	●	●	●	●	●	●	●
Voltmeter	<b>V</b>	0	0	0	0	0	0	0
Brine Version	<b>VB</b>	0	0	0	0	0	0	0

● Standard ○ Optional – Not available

- (1) Not available for HE versions  
 (2) Standard for U versions  
 (3) Available only with R454B (Kr)  
 (4) Standard for HE versions  
 (5) 4 poles for U versions (P24)

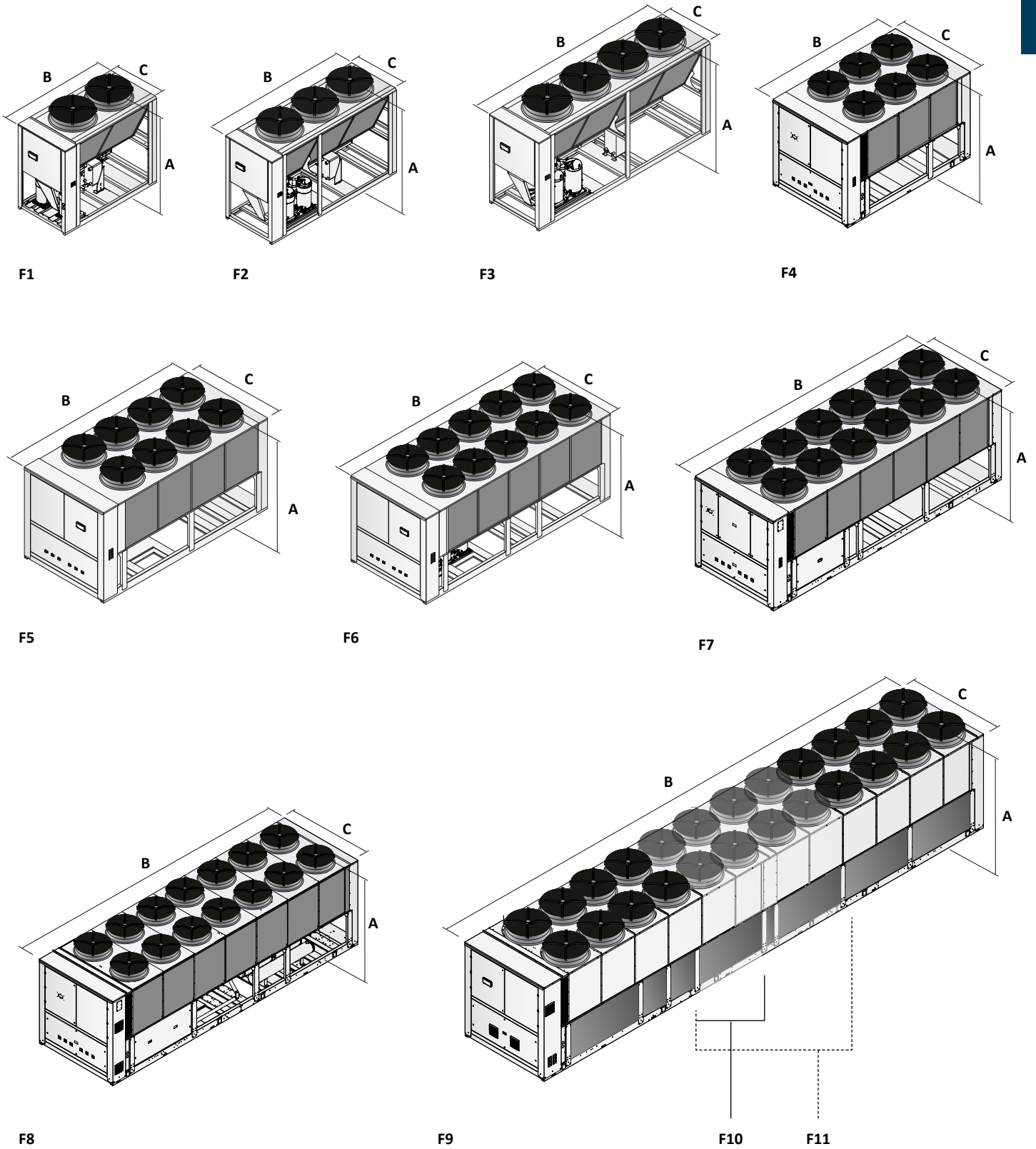

FRAME	F1	F2	F3	F4	F5	F6	F7	F8	F9	F10	F11
A (mm)	2420	2420	2420	2560	2560	2560	2560	2560	2560	2560	2560
B (mm)	2660	3700	4740	3775	4750	5725	6700	7250	9800	10680	12780
C (mm)	1370	1370	1370	2300	2300	2300	2300	2300	2300	2300	2300

# GPH VS

**HIGH EFFICIENCY AIR TO WATER MULTIPURPOSE UNIT AND 4 PIPE HEAT PUMPS**  
EQUIPPED WITH INVERTER SCREW COMPRESSORS AND AXIAL FAN  
WITH LOW GWP REFRIGERANT

Heating power from 480 kW to 1380 kW

R513A

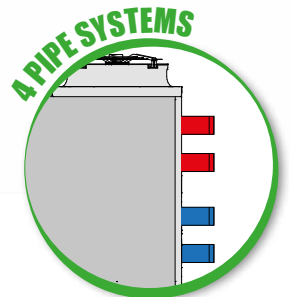

Multipurpose units, ideal for all installed applications where simultaneous production of hot and cold water is required, through the use of dedicated, independent circuits in 2- or 4-pipe hydronic systems. The polyvalent represents an effective and convenient alternative to traditional solutions ( Boiler + Chiller ) with a particular energy benefit in the conditions of demand for both fluids, hot and cold. The SEMI-HERMETIC SCREW compressor technology with INVERTER motor control, constantly modulating, guarantees a high capacity of partialisation of the cooling and heating power supplied, with a consequent increase in seasonal efficiency, also in applications with highly variable loads.

All the units are totally factory assembled and tested, following specific quality procedures. Besides they are totally hydraulic, cooling and electrical connected permitting a quick installation once on site. Before the test the cooling circuits of each unit are subjected to a pressure test and then charged with Refrigerant R513A and non-freezing oil.

## VERSIONS

**HE** High efficiency, EC fans.  
**U** Ultra low noise.

## TECHNICAL DATA

GPH VS Ke		402	502	602	702	802	902	1002	1102
Heating capacity (EN14511) <sup>(1)</sup>	kW	491,5	615,9	699,5	813,7	970,8	1080,9	1254,2	1329,7
Total input power (EN14511) <sup>(1)</sup>	kW	119,4	151,3	172,2	202,1	231,5	263,9	289,6	321,9
Input current	A	200,9	254,7	289,9	340,2	389,7	444,3	487,6	542,0
COP (EN14511) <sup>(1)</sup>	W/W	4,12	4,07	4,06	4,03	4,19	4,10	4,33	4,13
Cooling capacity (EN14511) <sup>(2)</sup>	kW	412,0	521,2	624,2	723,1	808,6	908,5	1050,6	1112,4
Total input power (EN14511) <sup>(2)</sup>	kW	155,1	193,0	217,4	251,6	290,8	334,9	367,1	416,5
Input current	A	261,1	324,9	365,9	423,6	489,5	563,8	618,0	701,2
EER (EN14511) <sup>(2)</sup>	W/W	2,66	2,70	2,87	2,87	2,78	2,71	2,86	2,67
Cooling capacity (EN14511) <sup>(3)</sup>	kW	487,0	612,4	713,0	838,4	968,2	1120,6	1277,2	1384,3
Heating capacity (EN14511) <sup>(3)</sup>	kW	576,5	725,3	841,2	987,1	1139,0	1308,8	1488,7	1628,5
Total input power (EN14511) <sup>(3)</sup>	kW	107,3	135,3	154,3	179,2	206,0	228,7	257,5	294,6
Input current	A	180,7	227,8	259,8	301,7	346,8	384,9	433,5	495,9
TER (EN14511) <sup>(3)</sup>	W/W	9,91	9,88	10,07	10,19	10,23	10,62	10,74	10,23
Sound power <sup>(4)</sup>	dB(A)	97,0	99,0	99,0	100,0	100,0	101,0	102,0	102,0
Sound pressure <sup>(5)</sup>	dB(A)	64,5	66,0	66,0	67,0	67,0	68,0	69,0	69,0
Power supply	V/ph/Hz	400/3/50							
Circuits	n°	2	2	2	2	2	2	2	2
Compressors	n°	2	2	2	2	2	2	2	2
Fans	n°	8	10	12	14	16	20	20	20
Refrigerant		R513A	R513A	R513A	R513A	R513A	R513A	R513A	R513A
Refrigerant charge	kg	162	181	348	463	490	527	550	564
Global warming potential	GWP	573	573	573	573	573	573	573	573
Equivalent CO <sub>2</sub> charge	t	102,1	114,4	219,7	292,1	308,9	332,8	347,0	356,1
Frame		5	6	7	8	9	10	10	10
Transport weight	kg	5535	6255	7762	9110	11617	12654	13190	13526
Operating weight	kg	5755	6495	8702	10144	12755	13905	14566	15040

GPH VS U Ke		402	502	602	702	802	902	1002	1102
Heating capacity (EN14511) <sup>(1)</sup>	kW	475,2	601,6	701,6	828,0	934,0	1095,2	1152,3	1305,2
Total input power (EN14511) <sup>(1)</sup>	kW	112,4	142,3	161,7	190,2	217,4	242,2	272,5	304,7
Input current	A	189,2	239,6	272,2	320,2	366,0	407,7	458,8	513,0
COP (EN14511) <sup>(1)</sup>	W/W	4,23	4,23	4,34	4,35	4,30	4,52	4,23	4,28
Cooling capacity (EN14511) <sup>(2)</sup>	kW	407,9	517,1	606,7	704,5	811,6	918,8	1040,3	1133,0
Total input power (EN14511) <sup>(2)</sup>	kW	150,4	188,7	212,4	248,4	284,3	311,8	354,3	395,5
Input current	A	253,2	317,7	357,6	418,2	478,6	524,9	596,5	665,9
EER (EN14511) <sup>(2)</sup>	W/W	2,71	2,74	2,86	2,84	2,86	2,95	2,94	2,86
Cooling capacity (EN14511) <sup>(3)</sup>	kW	487,0	612,4	713,0	838,4	968,2	1120,6	1277,2	1384,3
Heating capacity (EN14511) <sup>(3)</sup>	kW	576,5	725,3	841,2	987,1	1139,0	1308,8	1488,7	1628,5
Total input power (EN14511) <sup>(3)</sup>	kW	107,3	135,3	154,3	179,2	206,0	228,7	257,5	294,6
Input current	A	180,7	227,8	259,8	301,7	346,8	384,9	433,5	495,9
TER (EN14511) <sup>(3)</sup>	W/W	9,91	9,88	10,07	10,19	10,23	10,62	10,74	10,23
Sound power <sup>(4)</sup>	dB(A)	92	94	94	95	96	97	98	98
Sound pressure <sup>(5)</sup>	dB(A)	60	61	61	62	63	64	65	65
Power supply	V/ph/Hz	400/3/50							
Circuits	n°	2	2	2	2	2	2	2	2
Compressors	n°	2	2	2	2	2	2	2	2
Fans	n°	10	12	14	16	20	20	24	24
Refrigerant		R513A	R513A	R513A	R513A	R513A	R513A	R513A	R513A
Refrigerant charge	kg	181	202	463	490	550	564	636	665
Global warming potential	GWP	573	573	573	573	573	573	573	573
Equivalent CO <sub>2</sub> charge	t	114,4	127,3	292,1	308,9	347,0	356,1	401,3	419,4
Frame		6	7	8	9	10	10	24	24
Transport weight	kg	6335	7170	8972	11590	12437	13114	16400	16966
Operating weight	kg	6555	7410	9908	12630	13581	14372	17784	18489

Performances are referred to the following conditions:

- (1) Heating: Ambient temperature 7°C DB, 6°C WB, water temperature 30/35°C.  
 (2) Cooling: ambient air temperature 35°C, evaporator water temperature in/out 12/7 °C  
 (3) Cooling during heating : Outdoor air 7°C.

(4) Sound power level in accordance with ISO 3744.

(5) Sound pressure level at 10 mt from the unit in free field conditions in accordance with ISO 3744.

GPB VS HE Ke		402	502	602	702	802	902	1002	1102
Heating capacity (EN14511) <sup>(1)</sup>	kW	516,6	645,8	739,2	871,5	995,4	1113,0	1269,5	1375,5
Total input power (EN14511) <sup>(1)</sup>	kW	100,6	124,4	144,0	162,8	188,2	210,0	264,4	307,0
Input current	A	204,4	251,4	291,4	330,1	386,9	423,6	529,2	600,9
COP (EN14511) <sup>(1)</sup>	W/W	4,26	4,32	4,27	4,44	4,33	4,42	4,04	3,85
Cooling capacity (EN14511) <sup>(2)</sup>	kW	462,0	581,7	661,5	783,3	905,1	1000,7	1146,6	1239,0
Total input power (EN14511) <sup>(2)</sup>	kW	150,8	179,4	209,9	243,3	289,6	311,6	363,9	381,9
Input current	A	253,9	302,0	353,4	409,6	487,5	524,6	612,7	643,0
EER (EN14511) <sup>(2)</sup>	W/W	3,06	3,24	3,15	3,22	3,13	3,21	3,15	3,24
Cooling capacity (EN14511) <sup>(3)</sup>	kW	549,7	688,6	767,2	923,2	1085,2	1236,4	1408,8	1530,1
Heating capacity (EN14511) <sup>(3)</sup>	kW	644,8	805,5	903,0	1074,8	1261,6	1432,0	1655,6	1819,1
Total input power (EN14511) <sup>(3)</sup>	kW	108,4	133,4	154,3	173,6	202,2	224,8	280,7	326,1
Input current	A	182,4	224,5	259,7	292,2	340,4	378,4	472,5	549,1
TER (EN14511) <sup>(3)</sup>	W/W	11,02	11,20	10,83	11,51	11,61	11,87	10,92	10,27
Sound power <sup>(4)</sup>	dB(A)	95	96	101	99	100	101	100	101
Sound pressure <sup>(5)</sup>	dB(A)	63	64	69	66	67	68	67	68
Power supply	V/ph/Hz	400/3/50							
Circuits	n°	2	2	2	2	2	2	2	2
Compressors	n°	2	2	2	2	2	2	2	2
Fans	n°	10	12	14	16	20	20	24	24
Refrigerant		R513A	R513A	R513A	R513A	R513A	R513A	R513A	R513A
Refrigerant charge	kg	189	210	490	527	570	594	672	696
Global warming potential	GWP	573	573	573	573	573	573	573	573
Equivalent CO <sub>2</sub> charge	t	119,5	132,5	308,9	332,8	359,9	374,8	423,9	439,4
Frame		6	7	8	9	10	10	11	11
Transport weight	kg	6128	6750	9114	11480	12603	13347	16660	17305
Operating weight	kg	6370	7014	10144	12624	13862	14731	18182	18979

GPB VS HE U Ke		402	502	602	702	802	902	1002	
Heating capacity (EN14511) <sup>(1)</sup>	kW	485,1	627,9	716,1	844,2	963,9	1131,9	1281,0	
Total input power (EN14511) <sup>(1)</sup>	kW	106,1	137,4	159,4	185,8	207,0	272,2	293,8	
Input current	A	178,6	231,3	268,4	312,8	348,5	458,3	494,5	
COP (EN14511) <sup>(1)</sup>	W/W	4,57	4,57	4,49	4,54	4,66	4,16	4,36	
Cooling capacity (EN14511) <sup>(2)</sup>	kW	443,1	562,8	621,6	758,1	875,7	1010,1	1129,8	
Total input power (EN14511) <sup>(2)</sup>	kW	140,1	177,2	198,8	243,1	284,3	335,8	359,5	
Input current	A	235,8	298,2	334,7	409,2	478,6	565,3	605,2	
EER (EN14511) <sup>(2)</sup>	W/W	3,16	3,18	3,13	3,12	3,08	3,01	3,14	
Cooling capacity (EN14511) <sup>(3)</sup>	kW	549,7	688,6	767,2	923,2	1085,2	1236,4	1408,8	
Heating capacity (EN14511) <sup>(3)</sup>	kW	644,8	805,5	903,0	1074,8	1261,6	1432,0	1655,6	
Total input power (EN14511) <sup>(3)</sup>	kW	108,4	133,4	154,3	173,6	202,2	224,8	280,7	
Input current	A	182,4	224,5	259,7	292,2	340,4	378,4	472,5	
TER (EN14511) <sup>(3)</sup>	W/W	11,02	11,20	10,83	11,51	11,61	11,87	10,92	
Sound power <sup>(4)</sup>	dB(A)	89,0	90,0	97,0	96,0	97,0	95,0	96,0	
Sound pressure <sup>(5)</sup>	dB(A)	57,0	58,0	65,0	63,0	64,0	62,0	63,0	
Power supply	V/ph/Hz	400/3/50							
Circuits	n°	2	2	2	2	2	2	2	
Compressors	n°	2	2	2	2	2	2	2	
Fans	n°	12	14	16	20	20	24	24	
Refrigerant		R513A	R513A	R513A	R513A	R513A	R513A	R513A	
Refrigerant charge	kg	210	254	527	570	594	672	696	
Global warming potential	GWP	573	573	573	573	573	573	573	
Equivalent CO <sub>2</sub> charge	t	132,5	160,3	332,8	359,9	374,8	423,9	439,4	
Frame		7	8	9	10	10	11	11	
Transport weight	kg	6830	8375	11601	12663	13402	16768	17411	
Operating weight	kg	7094	9405	12745	13922	14786	18290	19085	

Performances are referred to the following conditions:

- (1) Heating: Ambient temperature 7°C DB, 6°C WB, water temperature 30/35°C.
- (2) Cooling: ambient air temperature 35°C, evaporator water temperature in/out 12/7 °C
- (3) Cooling during heating : Outdoor air 7°C.

(4) Sound power level in accordance with ISO 3744.

(5) Sound pressure level at 10 mt from the unit in free field conditions in accordance with ISO 3744.

## COMPONENTS

### FRAME

All units are made from hot-galvanised sheet steel, painted with polyurethane powder enamel and stoved at 180°C to provide maximum protection against corrosion. The frame is self-supporting with removable panels. All screws and rivets used are made from stainless steel. The standard colour of the units is RAL9018.

### REFRIGERANT CIRCUIT

The refrigerant circuit is assembled using internationally recognised brand name components with all brazing and welding being performed in accordance with ISO 97/23. The refrigerant utilised is R513A. The refrigerant circuit includes: sight glass, filter drier, electronic expansion valves, 4 way reversing valve, check valves, liquid receiver, liquid separator, schrader valves for maintenance and control, pressure safety device (for compliance with PED regulations).

### COMPRESSORS

Compressors of semi-hermetic screw type, controlled by integrated frequency inverter, allowing to adapt the power to the load variations ensuring at the same time the maximum efficiency at different operating conditions. The compressors are provided with motor thermal protection, rotation direction control, crank-case heater, oil filter, oil service valve, POE oil charge and vibration dumpers kit. Compressors lubrication is of forced type without pump, to avoid excessive oil migrations to the cooling circuit, compressors are equipped with an oil separator on discharge side. Both compressors are equipped with an oil flow safety switch, an optoelectronic device operating in case the oil flow inside the compressor falls below the minimum threshold.

### SOURCE HEAT EXCHANGER

Finned pack type, Copper/Aluminium, with micro-finned copper tubes, positioned in staggered rows and mechanically expanded into an aluminium finned pack. Fins are designed with such a shape providing the highest heat exchange efficiency. The max operating pressure refrigerant side is 45 relative bar.

### COOLING AND HEATING USER HEAT EXCHANGERS (SIZE 402-502)

The user heat exchanger is a braze welded, plate type heat exchanger, manufactured from AISI 316 stainless steel. The use of this type of exchanger results in a massive reduction of the refrigerant charge of the unit compared to a traditional shell-in-tube type. A further advantage is a reduction in the overall dimensions of the unit. The exchangers are factory insulated with flexible close cell material and can be fitted with an antifreeze heater (accessory). Each exchanger is fitted with a temperature sensor on the discharge water side for antifreeze protection.

### COOLING AND HEATING USER HEAT EXCHANGERS (SIZE 602-1102)

Tube bundle type with dry expansion and pure electrolytic copper tubes, shell and tube plate made up of carbon steel. The exchanger is provided with anti-condensation insulation made up of a nitrile rubber and polyethylene foam with a thickness of 8mm externally protected by an embossed scratchproof polyethylene film. The hydraulic connection are of elastic Vic-taulic type. Inside the shell, some plastic and corrosion-proof baffles, allowing a correct water distribution and making the tube bundle particularly strong and vibration free, even with high water flows. The evaporator is also provided with a safety water flow switch that does not allow the unit to operate in case of water flow rate lack to the evaporator.

### FANS

The fans are direct drive axial type with aerofoil blades, are statically and dynamically balanced and are supplied complete

with a safety fan guard complying with the requirements of EN 60335. They are fixed to the unit frame via rubber anti-vibration mountings. The electric motors, in standard versions are 6 poles type with or inverter that modulates its speed according to the ambient temperature. In the HE versions, the fans are electronic type, with permanent magnet motors with an integrated driver that modulates the speed of rotation. The motors are fitted with integrated thermal overload protection and have a moisture protection rating of IP 54.

### MICROPROCESSORS

All units are supplied as standard with microprocessor controls. The microprocessor controls the following functions: control of the water temperature, antifreeze protection, compressor timing, compressor automatic starting sequence (For multiple compressors), alarm reset.

The control panel is supplied with display showing all operational icons. The microprocessor is set for automatic defrost (when operating in severe ambient conditions) and for summer/ winter change over. The control also manages the integration with other heating sources (electric heaters, boilers, solar panels etc) and both the heating circuit pump and the domestic hot water circuit pump. If required (available as an option), the microprocessor can be configured in order for it to connect to a site BMS system thus enabling remote control and management.

### ELECTRIC ENCLOSURE

The enclosure is manufactured in order to comply with the requirements of the electromagnetic compatibility standards 2014/35/UE and 2014/30/UE. Access to the enclosure is achieved by removing the front panel of the unit. The following components are supplied as standard on all units: main switch, a sequence relay that disables the power supply in the event that the phase sequence is incorrect (scroll compressors can be damaged if they rotate in the wrong direction), thermal overloads (protection of pumps and fans), compressor fuses, control circuit automatic breakers, compressor contactors, fan contactors and pump contactors. The terminal board has volt free contacts for remote ON-OFF, Summer/ winter change over (heat pumps only) and general alarm.

### CONTROL AND PROTECTION DEVICES

All units are standardly equipped with several control and safety devices: water return temperature sensor, installed on the water return pipe of the system, and anti-freeze probe, installed on the water supply pipe to the system high-pressure switch with automatic reset. There are also included a low-pressure automatic reset, pressure transducer (used to optimize the defrosting cycle and modulate the rotation speed of the fans according to external conditions), Freon side safety device, compressor thermal protection, fan thermal protection, flow switch.

# OPERATION LIMITS

## Standard version

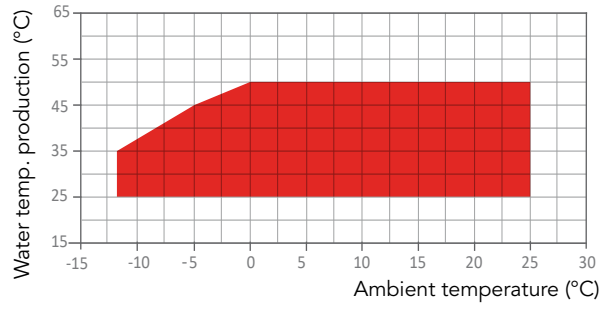
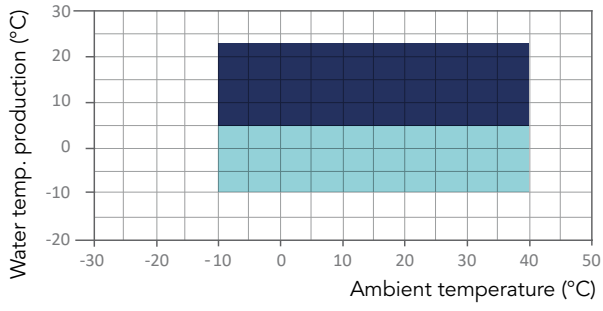

## HE version

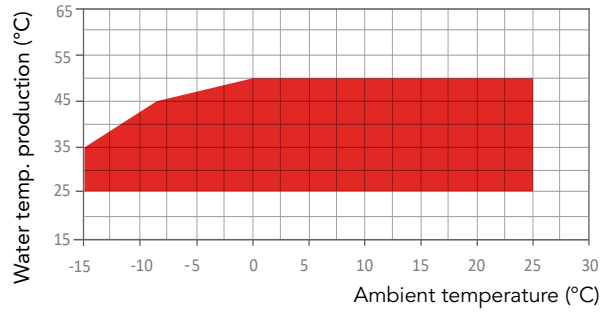
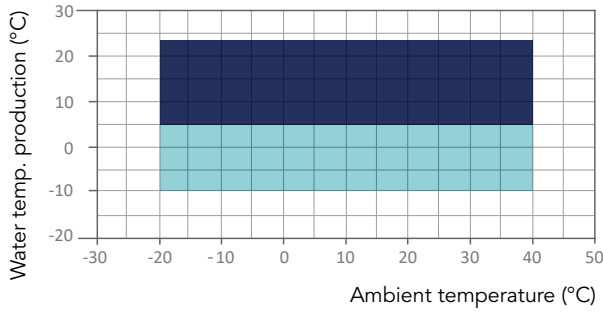

Cooling mode  
 Glycol set-up

Heating mode

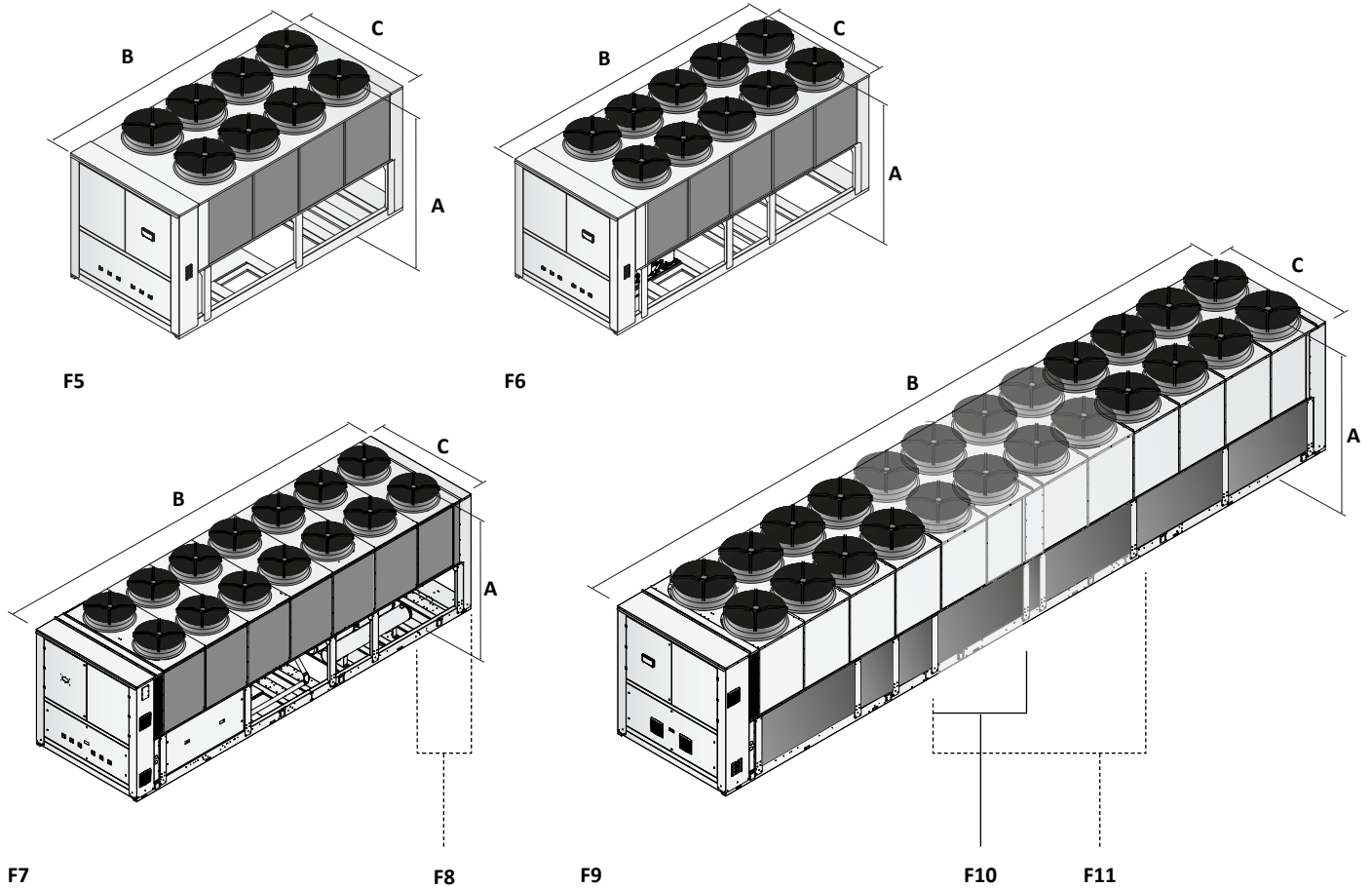

FRAME	F5	F6	F7	F8	F9	F10	F11
A (mm)	2560	2560	2560	2560	2560	2560	2560
B (mm)	4750	5725	6700	7250	9800	10680	12780
C (mm)	2300	2300	2300	2300	2300	2300	2300

## ACCESSORIES

GPH VS Ke		402	502	602	702	802	902	1002	1102
Amperometer	<b>A</b>	○	○	○	○	○	○	○	○
Electrical power supply different than standard	<b>AE</b>	○	○	○	○	○	○	○	○
Electrofin Coil Treatment	<b>BEF</b>	○	○	○	○	○	○	○	○
Operation in cooling mode down to -20°C	<b>BF</b>	○	○	○	○	○	○	○	○
Soundproofed compressors cabinet with standard material	<b>CF</b>	●	●	●	●	●	●	●	●
Soundproofed compressors cabinet with higher thickness material	<b>CFU</b> <sup>(1)</sup>	○	○	○	○	○	○	○	○
Soundproofing jacket on compressors	<b>CI</b>	○	○	○	○	○	○	○	○
Compressors inrush counter	<b>CS</b>	○	○	○	○	○	○	○	○
Condensing coil protection grid	<b>GP</b>	○	○	○	○	○	○	○	○
Anti-intrusion grid	<b>GP3</b>	○	○	○	○	○	○	○	○
Victaulic insulation on pump side	<b>I1</b>	○	○	○	○	○	○	○	○
Victaulic insulation buffer tank side	<b>I2</b>	○	○	○	○	○	○	○	○
RS 485 Serial interface	<b>IH</b>	○	○	○	○	○	○	○	○
Seawood packing	<b>IM</b>	○	○	○	○	○	○	○	○
TCP/IP Protocol serial interface	<b>IWG</b>	○	○	○	○	○	○	○	○
Phase monitor	<b>MF</b>	○	○	○	○	○	○	○	○
Buffer tank module	<b>MV</b>	○	○	○	○	○	○	○	○
Pump group	<b>P1</b>	○	○	○	○	○	○	○	○
Pump + tank	<b>P1+MV</b>	○	○	○	○	○	○	○	○
Pump Variable flow 2 Poles high prevalence	<b>P12HVS</b> <sup>(2)</sup>	○	○	○	○	○	○	○	○
Pump Variable flow 2 Poles high prevalence + tank	<b>P12HVS+MV</b> <sup>(2)</sup>	○	○	○	○	○	○	○	○
Pump Variable flow 2 Poles	<b>P12VS</b> <sup>(2)</sup>	○	○	○	○	○	○	○	○
Pump Variable flow 2 Poles + tank	<b>P12VS+MV</b> <sup>(2)</sup>	○	○	○	○	○	○	○	○
Higher available pressure pump group	<b>P1H</b>	○	○	○	○	○	○	○	○
Higher available pressure pump group + tank	<b>P1H+MV</b>	○	○	○	○	○	○	○	○
Double pump group	<b>P2</b>	○	○	○	○	○	○	○	○
Double pump group + tank	<b>P2+MV</b>	○	○	○	○	○	○	○	○
Double pump group Variable flow 2 Poles high prevalence	<b>P22HVS</b> <sup>(2)</sup>	○	○	○	○	○	○	○	○
Double pump group Variable flow 2 Poles high prevalence + tank	<b>P22HVS+MV</b> <sup>(2)</sup>	○	○	○	○	○	○	○	○
Double pump group Variable flow 2 Poles	<b>P22VS</b> <sup>(2)</sup>	○	○	○	○	○	○	○	○
Double pump group Variable flow 2 Poles + tank	<b>P22VS+MV</b> <sup>(2)</sup>	○	○	○	○	○	○	○	○
Higher available pressure double pump group	<b>P2H</b>	○	○	○	○	○	○	○	○
Higher available pressure double pump group + tank	<b>P2H+MV</b>	○	○	○	○	○	○	○	○
Rubber-type vibration dampers	<b>PA</b>	○	○	○	○	○	○	○	○
Spring-type vibration dampers	<b>PM</b>	○	○	○	○	○	○	○	○
Remote display	<b>PQ</b>	○	○	○	○	○	○	○	○
In-line twin pump group (only one working)	<b>PT</b>	○	○	○	○	○	○	○	○
In-line twin pump group (only one working) + tank	<b>PT+MV</b>	○	○	○	○	○	○	○	○
In-line twin pump group Variable flow	<b>PTVS</b>	○	○	○	○	○	○	○	○
In-line twin pump group Variable flow + tank	<b>PTVS+MV</b>	○	○	○	○	○	○	○	○
Anti-freeze heater on evaporator	<b>RA</b>	○	○	○	○	○	○	○	○
Shut-off valve on compressors discharge side	<b>RD</b>	○	○	○	○	○	○	○	○
Shut-off valve on compressors suction side	<b>RH</b>	○	○	○	○	○	○	○	○
Compressor overload relays	<b>RL</b>	○	○	○	○	○	○	○	○
Batteria con alette prevenciate	<b>RM</b>	○	○	○	○	○	○	○	○
Partial heat recovery	<b>RP</b>	○	○	○	○	○	○	○	○
Copper/Copper coil	<b>RR</b>	○	○	○	○	○	○	○	○
Electronic thermostatic valve	<b>TE</b>	●	●	●	●	●	●	●	●
Voltmeter	<b>V</b>	○	○	○	○	○	○	○	○
Brine Version	<b>VB</b>	○	○	○	○	○	○	○	○
Solenoid valve	<b>VS</b>	○	○	○	○	○	○	○	○

(1) Standard for U versions

(2) 4 poles for U versions (P14 / P24)

● Standard ○ Optional – Not available

# LZT/P4

**HIGH EFFICIENCY AIR TO WATER MULTIPURPOSE UNIT AND 4 PIPE HEAT PUMPS  
EQUIPPED WITH E.V.I. COMPRESSORS AND AXIAL FANS**

Heating power from 24 kW to 205 kW

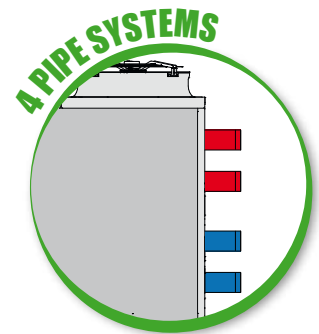
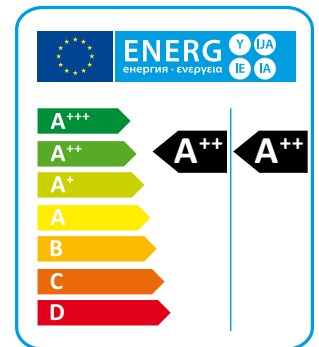

The high efficiency air / water heat pumps of the LZT/P4 series are units designed for 4-pipe air conditioning and heating systems, which allow the production of cold water for cooling and hot water for heating at the same time or separately.

The units are supplied with an additional exchanger, used as a condenser for hot water, the production of which is independent of the operation mode of the unit.

Activation of the exchanger takes place automatically via the microprocessor control when the hot water temperature on the return is lower than the set point. These units are able to produce hot water and cold water simultaneously and / or separately with very high energy efficiencies.

They are all supplied complete with a specific advanced microprocessor control provided with software for managing the various priorities.

The XL versions also have an extremely low noise level thanks to the use of a special floating vibration damping system that allows a noise reduction of about 6-8 dB (A) (optional).

## VERSIONS

- P4U** 4 pipe systems heating/cooling.
- P4S** 2+2 pipe systems with D.H.W. production.
- SA** Standard efficiency, AC fans.
- SE** Standard efficiency, EC fans.
- HA** High efficiency, AC fans.
- HE** High efficiency, EC fans.
- LS** Low noise.
- XL** Super low noise.
- NN** Ultra low noise.

## TECHNICAL DATA

SA/LS/RV - P4U/P4S		242	292	432	492	592	752	852
Heating capacity (EN14511) <sup>(1)</sup>	kW	23,7	28,3	42,1	50,9	55,0	67,8	74,5
Total input power (EN14511) <sup>(1)</sup>	kW	5,5	6,8	10,3	12,3	13,4	16,3	18,3
COP (EN14511) <sup>(1)</sup>	W/W	4,31	4,16	4,11	4,14	4,12	4,16	4,07
Energy Class in low temperature <sup>(2)</sup>		A+	A+	A+	A+	A+	A+	A+
SCOP low temperature <sup>(2)</sup>	kWh/kWh	3,75	3,77	3,39	3,33	3,49	3,70	3,62
η <sub>s,h</sub> low temperature <sup>(2)</sup>	%	147	148	133	130	137	145	142
Energy Class in medium temperature <sup>(2)</sup>		A+	A+	A+	A+	A+	A+	A+
SCOP medium temperature <sup>(2)</sup>	kWh/kWh	3,04	3,07	2,89	2,87	2,93	3,06	3,03
η <sub>s,h</sub> medium temperature <sup>(2)</sup>	%	119	120	112	112	114	119	118
Cooling capacity (EN14511) <sup>(3)</sup>	kW	22,5	29,5	36,4	46,1	53,6	61,6	74,3
Total input power (EN14511) <sup>(3)</sup>	kW	7,1	9,1	12,9	16,4	19,3	22,3	25,5
EER (EN14511) <sup>(3)</sup>	W/W	3,15	3,24	2,82	2,80	2,78	2,76	2,91
Sound power <sup>(4)</sup>	dB (A)	78	78	79	80	80	80	80
Sound pressure <sup>(5)</sup>	dB (A)	46	46	47	48	48	48	48
SE/LS/RV - P4U/P4S		242	292	432	492	592	752	852
Heating capacity (EN14511) <sup>(1)</sup>	kW	23,7	28,3	42,1	50,5	55,2	67,8	74,7
Total input power (EN14511) <sup>(1)</sup>	kW	5,3	6,7	9,9	12,8	13,8	16,1	18,2
COP (EN14511) <sup>(1)</sup>	W/W	4,47	4,22	4,25	3,95	4,00	4,21	4,10
Energy Class in low temperature <sup>(2)</sup>		A++	A++	A+	A+	A+	A+	A+
SCOP low temperature <sup>(2)</sup>	kWh/kWh	3,95	3,87	3,58	3,45	3,59	3,79	3,68
η <sub>s,h</sub> low temperature <sup>(2)</sup>	%	155	152	140	135	141	149	144
Energy Class in medium temperature <sup>(2)</sup>		A+	A+	A+	A+	A+	A+	A+
SCOP medium temperature <sup>(2)</sup>	kWh/kWh	3,17	3,13	3,02	2,99	3,02	3,13	3,10
η <sub>s,h</sub> medium temperature <sup>(2)</sup>	%	124	122	118	116	118	122	121
Cooling capacity (EN14511) <sup>(3)</sup>	kW	22,65	29,92	36,5	46,43	53,75	61,94	74,64
Total input power (EN14511) <sup>(3)</sup>	kW	7,1	9,0	12,8	16,2	19,2	21,9	25,4
EER (EN14511) <sup>(3)</sup>	W/W	3,19	3,32	2,86	2,86	2,81	2,83	2,94
Sound power <sup>(4)</sup>	dB (A)	78	78	79	80	80	80	80
Sound pressure <sup>(5)</sup>	dB (A)	46	46	47	48	48	48	48
Power supply	V/Ph/Hz	400/3+N/50	400/3+N/50	400/3/50	400/3/50	400/3/50	400/3/50	400/3/50
Compressors / Circuits	n° / n°	2 / 1	2 / 1	2 / 1	2 / 1	2 / 1	2 / 1	2 / 1
Fans	n°	1	1	2	2	2	2	2
Refrigerant		R410A	R410A	R410A	R410A	R410A	R410A	R410A
Refrigerant charge	kg	10,0	10,0	10,0	12,0	12,0	18,0	19,0
Global warming potential (GWP)		2088	2088	2088	2088	2088	2088	2088
Equivalent CO <sub>2</sub> charge	t	20,88	20,88	20,88	25,05	25,05	37,58	39,67
Water tank volume	l	100	100	100	100	100	300	300
SA/LS/RV - P4U/P4S		1002	1202	1454	1654	1854	2154	
Heating capacity (EN14511) <sup>(1)</sup>	kW	88,5	102,5	145,3	162,9	180,2	205,4	
Total input power (EN14511) <sup>(1)</sup>	kW	21,1	25,8	35,2	41,2	43,6	52,9	
COP (EN14511) <sup>(1)</sup>	W/W	4,21	3,98	4,13	3,96	4,13	3,88	
Energy Class in low temperature <sup>(2)</sup>		A+	A+	A+	A+	A+	A+	
SCOP low temperature <sup>(2)</sup>	kWh/kWh	3,61	3,60	3,44	3,42	3,43	3,42	
η <sub>s,h</sub> low temperature <sup>(2)</sup>	%	141	141	135	134	134	134	
Energy Class in medium temperature <sup>(2)</sup>		A+	A+	A+	A+	A+	A+	
SCOP medium temperature <sup>(2)</sup>	kWh/kWh	3,01	2,99	2,85	2,90	2,92	2,95	
η <sub>s,h</sub> medium temperature <sup>(2)</sup>	%	117	117	111	113	114	115	
Cooling capacity (EN14511) <sup>(3)</sup>	kW	77,9	90,4	125,8	142,0	155,1	177,9	
Total input power (EN14511) <sup>(3)</sup>	kW	26,9	32,6	44,1	51,7	55,3	68,6	
EER (EN14511) <sup>(3)</sup>	W/W	2,89	2,77	2,85	2,75	2,80	2,59	
Sound power <sup>(4)</sup>	dB (A)	80	80	87	87	88	89	
Sound pressure <sup>(5)</sup>	dB (A)	48	48	55	55	56	57	
SE/LS/RV - P4U/P4S		1002	1202	1454	1654	1854	2154	
Heating capacity (EN14511) <sup>(1)</sup>	kW	88,2	102,5	146,0	164,3	181,3	208,1	
Total input power (EN14511) <sup>(1)</sup>	kW	20,7	25,4	33,6	39,03	41,91	50,66	
COP (EN14511) <sup>(1)</sup>	W/W	4,26	4,03	4,35	4,21	4,33	4,11	
Energy Class in low temperature <sup>(2)</sup>		A+	A+	A+	A+	A+	A+	
SCOP low temperature <sup>(2)</sup>	kWh/kWh	3,69	3,70	3,63	3,57	3,69	3,63	
η <sub>s,h</sub> low temperature <sup>(2)</sup>	%	145	145	142	140	145	142	
Energy Class in medium temperature <sup>(2)</sup>		A+	A+	A+	A+	A+	A+	
SCOP medium temperature <sup>(2)</sup>	kWh/kWh	3,10	3,06	2,95	2,99	3,06	3,07	
η <sub>s,h</sub> medium temperature <sup>(2)</sup>	%	121	120	115	117	120	120	
Cooling capacity (EN14511) <sup>(3)</sup>	kW	78,1	90,9	126,4	143,1	156,3	179,3	
Total input power (EN14511) <sup>(3)</sup>	kW	25,0	32,1	41,7	49,5	53,5	66,1	
EER (EN14511) <sup>(3)</sup>	W/W	3,13	2,83	3,03	2,89	2,92	2,71	
Sound power <sup>(4)</sup>	dB (A)	80	80	86	87	88	89	
Sound pressure <sup>(5)</sup>	dB (A)	48	48	54	55	56	57	
Power supply	V/Ph/Hz	400/3/50	400/3/50	400/3/50	400/3/50	400/3/50	400/3/50	
Compressors / Circuits	n° / n°	2 / 1	2 / 1	4/2	4/2	4/2	4/2	
Fans	n°	3	4	4	4	4	4	
Refrigerant		R410A	R410A	R410A	R410A	R410A	R410A	
Refrigerant charge	kg	23,0	23,0	45,0	45,0	50,0	50,0	
Global warming potential (GWP)		2088	2088	2088	2088	2088	2088	
Equivalent CO <sub>2</sub> charge	t	48,02	48,02	93,96	93,96	104,40	104,40	
Water tank volume	l	300	300	500	500	500	500	

Performances are referred to the following conditions:

(1) Heating: Ambient temperature 7°C DB, 6°C WB, water temperature 30/35°C.

(2) Average conditions, variable - Reg EU 811/2013

(3) Cooling: ambient air temperature 35°C, evaporator water temperature in/out 12/7 °C.

(4) Sound power level in accordance with ISO 3744..

(5) Sound pressure level at 10 mt from the unit in free field conditions in accordance with ISO 3744.

HA/LS/RV - P4U/P4S		242	292	432	492	602	752	852
Heating capacity (EN14511) <sup>(1)</sup>	kW	23,8	29,4	41,6	51,2	58,0	66,7	80,8
Total input power (EN14511) <sup>(1)</sup>	kW	5,3	6,8	9,7	12,4	13,0	15,6	19,6
COP (EN14511) <sup>(1)</sup>	W/W	4,51	4,31	4,29	4,12	4,45	4,29	4,13
Energy Class in low temperature <sup>(2)</sup>		A++	A++	A+	A+	A++	A++	A+
SCOP low temperature <sup>(2)</sup>	kWh/kWh	3,96	3,89	3,63	3,55	3,94	3,95	3,76
$\eta_{s,h}$ low temperature <sup>(2)</sup>	%	155	153	142	139	155	155	147
Energy Class in medium temperature <sup>(2)</sup>		A+	A+	A+	A+	A++	A+	A+
SCOP medium temperature <sup>(2)</sup>	kWh/kWh	3,18	3,15	2,99	2,98	3,21	3,16	3,01
$\eta_{s,h}$ medium temperature <sup>(2)</sup>	%	124	123	117	116	126	123	117
Cooling capacity (EN14511) <sup>(3)</sup>	kW	22,9	30,1	37,5	46,7	52,8	62,5	71,6
Total input power (EN14511) <sup>(3)</sup>	kW	7,0	9,0	12,7	16,1	18,1	21,6	24,6
EER (EN14511) <sup>(3)</sup>	W/W	3,25	3,36	2,97	2,90	2,91	2,89	2,91
Sound power <sup>(4)</sup>	dB (A)	78	78	78	79	80	80	83
Sound pressure <sup>(5)</sup>	dB (A)	46	46	46	47	48	48	51
HE/LS/RV - P4U/P4S		242	292	432	492	602	752	852
Heating capacity (EN14511) <sup>(1)</sup>	kW	24,0	29,5	41,8	50,3	58,3	66,9	81,3
Total input power (EN14511) <sup>(1)</sup>	kW	5,2	6,7	9,5	12,2	12,8	15,3	18,9
COP (EN14511) <sup>(1)</sup>	W/W	4,61	4,38	4,40	4,12	4,56	4,37	4,31
Energy Class in low temperature <sup>(2)</sup>		A++	A++	A++	A++	A++	A++	A++
SCOP low temperature <sup>(2)</sup>	kWh/kWh	4,10	3,96	3,87	3,83	4,08	4,06	3,83
$\eta_{s,h}$ low temperature <sup>(2)</sup>	%	161	156	152	150	160	159	150
Energy Class in medium temperature <sup>(2)</sup>		A++	A++	A+	A+	A++	A++	A+
SCOP medium temperature <sup>(2)</sup>	kWh/kWh	3,25	3,21	3,12	3,15	3,29	3,23	3,07
$\eta_{s,h}$ medium temperature <sup>(2)</sup>	%	127	125	122	123	129	126	120
Cooling capacity (EN14511) <sup>(3)</sup>	kW	22,9	30,2	37,5	45,6	52,9	62,5	71,6
Total input power (EN14511) <sup>(3)</sup>	kW	7,0	8,8	12,7	16,7	17,9	21,3	24,4
EER (EN14511) <sup>(3)</sup>	W/W	3,27	3,42	2,96	2,73	2,95	2,64	2,94
Sound power <sup>(4)</sup>	dB (A)	78	78	78	79	80	80	83
Sound pressure <sup>(5)</sup>	dB (A)	46	46	46	47	48	48	51
Power supply	V/Ph/Hz	400/3+N/50	400/3+N/50	400/3/50	400/3/50	400/3/50	400/3/50	400/3/50
Compressors / Circuits	n° / n°	2 / 1	2 / 1	2 / 1	2 / 1	2 / 1	2 / 1	2 / 1
Fans	n°	1	1	2	2	2	2	2
Refrigerant		R410A	R410A	R410A	R410A	R410A	R410A	R410A
Refrigerant charge	kg	10,0	10,0	14,5	12,0	18,0	23,0	23,0
Global warming potential (GWP)		2088	2088	2088	2088	2088	2088	2088
Equivalent CO <sub>2</sub> charge	t	20,88	20,88	30,27	25,05	37,58	48,02	48,02
Water tank volume	l	100	100	100	100	300	300	300

HA/LS/RV - P4U/P4S		1002	1202	1454	1654	1854	2154
Heating capacity (EN14511) <sup>(1)</sup>	kW	88,4	102,5	145,6	163,7	181,9	210,2
Total input power (EN14511) <sup>(1)</sup>	kW	21,4	25,3	35,2	40,7	43,8	52,2
COP (EN14511) <sup>(1)</sup>	W/W	4,13	4,05	4,14	4,02	4,16	4,02
Energy Class in low temperature <sup>(2)</sup>		A+	A+	A+	A+	A+	A+
SCOP low temperature <sup>(2)</sup>	kWh/kWh	3,80	3,78	3,74	3,65	3,79	3,78
$\eta_{s,h}$ low temperature <sup>(2)</sup>	%	149	148	147	143	149	148
Energy Class in medium temperature <sup>(2)</sup>		A+	A+	A+	A+	A+	A+
SCOP medium temperature <sup>(2)</sup>	kWh/kWh	3,05	3,06	3,05	3,03	3,12	3,16
$\eta_{s,h}$ medium temperature <sup>(2)</sup>	%	119	120	119	118	122	123
Cooling capacity (EN14511) <sup>(3)</sup>	kW	78,1	90,2	127,4	143,5	157,8	180,9
Total input power (EN14511) <sup>(3)</sup>	kW	26,6	32,2	42,4	50,8	53,6	66,5
EER (EN14511) <sup>(3)</sup>	W/W	2,94	2,80	3,01	2,82	2,94	2,72
Sound power <sup>(4)</sup>	dB (A)	83	83	84	85	85	85
Sound pressure <sup>(5)</sup>	dB (A)	51	51	52	53	53	53
HE/LS/RV - P4U/P4S		1002	1202	1454	1654	1854	2154
Heating capacity (EN14511) <sup>(1)</sup>	kW	88,5	102,7	145,2	163,2	181,3	209,6
Total input power (EN14511) <sup>(1)</sup>	kW	20,6	24,6	33,4	38,9	41,9	50,5
COP (EN14511) <sup>(1)</sup>	W/W	4,31	4,17	4,35	4,19	4,33	4,15
Energy Class in low temperature <sup>(2)</sup>		A++	A++	A++	A++	A++	A++
SCOP low temperature <sup>(2)</sup>	kWh/kWh	3,85	3,84	3,88	3,88	3,89	3,89
$\eta_{s,h}$ low temperature <sup>(2)</sup>	%	151	151	152	152	153	153
Energy Class in medium temperature <sup>(2)</sup>		A+	A+	A+	A+	A+	A+
SCOP medium temperature <sup>(2)</sup>	kWh/kWh	3,14	3,13	3,10	3,15	3,17	3,19
$\eta_{s,h}$ medium temperature <sup>(2)</sup>	%	123	122	121	123	124	124
Cooling capacity (EN14511) <sup>(3)</sup>	kW	78,2	90,8	126,8	142,8	157,0	180,1
Total input power (EN14511) <sup>(3)</sup>	kW	26,1	31,3	42,0	50,5	53,4	66,2
EER (EN14511) <sup>(3)</sup>	W/W	3,00	2,90	3,02	2,83	2,94	2,72
Sound power <sup>(4)</sup>	dB (A)	83	83	84	85	85	85
Sound pressure <sup>(5)</sup>	dB (A)	51	51	52	53	53	53
Power supply	V/Ph/Hz	400/3/50	400/3/50	400/3/50	400/3/50	400/3/50	400/3/50
Compressors / Circuits	n° / n°	2 / 1	2 / 1	4/2	4/2	4/2	4/2
Fans	n°	2	2	3	3	3	3
Refrigerant		R410A	R410A	R410A	R410A	R410A	R410A
Refrigerant charge	kg	27,0	27,0	45,0	45,0	50,0	50,0
Global warming potential (GWP)		2088	2088	2088	2088	2088	2088
Equivalent CO <sub>2</sub> charge	t	56,37	56,37	93,96	93,96	104,40	104,40
Water tank volume	l	300	300	500	500	500	500

Performances are referred to the following conditions:

(1) Heating: Ambient temperature 7°C DB, 6°C WB, water temperature 30/35°C.

(2) Average conditions, variable - Reg EU 811/2013

(3) Cooling: ambient air temperature 35°C, evaporator water temperature in/out 12/7 °C.

(4) Sound power level in accordance with ISO 3744..

(5) Sound pressure level at 10 mt from the unit in free field conditions in accordance with ISO 3744.

HA/XL/RV - P4U/P4S		252	302	432	492	602	752	852
Heating capacity (EN14511) <sup>(1)</sup>	kW	24,0	29,6	41,1	48,9	57,4	65,5	80,1
Total input power (EN14511) <sup>(1)</sup>	kW	5,5	7,0	9,5	12,1	12,9	15,2	18,4
COP (EN14511) <sup>(1)</sup>	W/W	4,40	4,24	4,35	4,04	4,46	4,31	4,35
Energy Class in low temperature <sup>(2)</sup>		A++	A++	A++	A++	A++	A++	A++
SCOP low temperature <sup>(2)</sup>	kWh/kWh	3,83	3,84	3,84	3,83	4,03	4,01	3,83
$\eta_{s,h}$ low temperature <sup>(2)</sup>	%	150	151	151	150	158	158	150
Energy Class in medium temperature <sup>(2)</sup>		A+	A+	A+	A+	A++	A+	A+
SCOP medium temperature <sup>(2)</sup>	kWh/kWh	3,05	3,13	3,11	3,14	3,27	3,20	3,13
$\eta_{s,h}$ medium temperature <sup>(2)</sup>	%	119	122	121	122	128	125	122
Cooling capacity (EN14511) <sup>(3)</sup>	kW	22,0	28,3	36,8	45,5	52,1	62,0	71,2
Total input power (EN14511) <sup>(3)</sup>	kW	7,1	9,1	13,2	16,1	18,9	21,9	23,7
EER (EN14511) <sup>(3)</sup>	W/W	3,10	3,13	2,78	2,82	2,75	2,83	3,00
Sound power <sup>(4)</sup>	dB (A)	72	72	73	74	74	74	74
Sound pressure <sup>(5)</sup>	dB (A)	40	40	41	42	42	42	42
HE/XL/RV - P4U/P4S		252	302	432	492	602	752	852
Heating capacity (EN14511) <sup>(1)</sup>	kW	24,0	30,0	41,2	49,2	57,4	65,6	79,9
Total input power (EN14511) <sup>(1)</sup>	kW	5,2	6,8	9,2	11,8	12,6	15,1	17,8
COP (EN14511) <sup>(1)</sup>	W/W	4,64	4,39	4,49	4,16	4,57	4,35	4,49
Energy Class in low temperature <sup>(2)</sup>		A++	A++	A++	A++	A++	A++	A++
SCOP low temperature <sup>(2)</sup>	kWh/kWh	4,10	3,87	4,00	3,84	4,21	4,16	4,04
$\eta_{s,h}$ low temperature <sup>(2)</sup>	%	161	152	157	151	165	163	159
Energy Class in medium temperature <sup>(2)</sup>		A++	A+	A++	A++	A++	A++	A++
SCOP medium temperature <sup>(2)</sup>	kWh/kWh	3,24	3,14	3,24	3,16	3,38	3,29	3,26
$\eta_{s,h}$ medium temperature <sup>(2)</sup>	%	127	123	127	123	132	129	127
Cooling capacity (EN14511) <sup>(3)</sup>	kW	21,0	28,9	37,2	45,7	52,0	62,1	70,6
Total input power (EN14511) <sup>(3)</sup>	kW	7,0	9,1	12,7	16,0	18,8	21,8	24,2
EER (EN14511) <sup>(3)</sup>	W/W	2,98	3,17	2,93	2,85	2,78	2,85	2,92
Sound power <sup>(4)</sup>	dB (A)	71	72	73	74	73	73	74
Sound pressure <sup>(5)</sup>	dB (A)	39	40	41	42	41	41	42
Power supply	V/Ph/Hz	400/3+N/50	400/3+N/50	400/3/50	400/3/50	400/3/50	400/3/50	400/3/50
Compressors / Circuits	n° / n°	2 / 1	2 / 1	2 / 1	2 / 1	2 / 1	2 / 1	2 / 1
Fans	n°	2	2	2	2	2	2	2
Refrigerant		R410A	R410A	R410A	R410A	R410A	R410A	R410A
Refrigerant charge	kg	10,0	10,0	14,5	12,0	18,0	23,0	23,0
Global warming potential (GWP)		2088	2088	2088	2088	2088	2088	2088
Equivalent CO <sub>2</sub> charge	t	20,88	20,88	30,27	25,05	37,58	48,02	48,02
Water tank volume	l	100	100	100	100	300	300	300

HA/XL/RV - P4U/P4S		1002	1202	1454	1654	1854	2154
Heating capacity (EN14511) <sup>(1)</sup>	kW	87,3	100,7	147,8	166,9	187,4	218,2
Total input power (EN14511) <sup>(1)</sup>	kW	20,0	23,8	33,5	38,7	43,1	51,3
COP (EN14511) <sup>(1)</sup>	W/W	4,37	4,23	4,41	4,31	4,35	4,25
Energy Class in low temperature <sup>(2)</sup>		A++	A++	A++	A++	A++	A++
SCOP low temperature <sup>(2)</sup>	kWh/kWh	3,91	3,84	3,93	3,90	3,88	3,88
$\eta_{s,h}$ low temperature <sup>(2)</sup>	%	153	151	154	153	152	152
Energy Class in medium temperature <sup>(2)</sup>		A++	A+	A+	A+	A+	A+
SCOP medium temperature <sup>(2)</sup>	kWh/kWh	3,21	3,18	3,16	3,17	3,10	3,13
$\eta_{s,h}$ medium temperature <sup>(2)</sup>	%	126	124	123	124	121	122
Cooling capacity (EN14511) <sup>(3)</sup>	kW	77,1	88,7	126,6	143,4	158,7	184,3
Total input power (EN14511) <sup>(3)</sup>	kW	26,2	32,6	40,9	48,1	49,7	61,3
EER (EN14511) <sup>(3)</sup>	W/W	2,95	2,72	3,10	2,98	3,19	3,01
Sound power <sup>(4)</sup>	dB (A)	75	75	79	79	80	80
Sound pressure <sup>(5)</sup>	dB (A)	43	43	47	47	48	48
HE/XL/RV - P4U/P4S		1002	1202	1454	1654	1854	2154
Heating capacity (EN14511) <sup>(1)</sup>	kW	87,2	100,7	147,6	166,6	187,6	218,2
Total input power (EN14511) <sup>(1)</sup>	kW	19,4	23,5	32,3	37,6	41,2	49,5
COP (EN14511) <sup>(1)</sup>	W/W	4,49	4,29	4,57	4,43	4,55	4,41
Energy Class in low temperature <sup>(2)</sup>		A++	A++	A++	A++	A++	A++
SCOP low temperature <sup>(2)</sup>	kWh/kWh	4,06	3,93	4,10	4,00	3,94	3,92
$\eta_{s,h}$ low temperature <sup>(2)</sup>	%	160	154	161	157	154	154
Energy Class in medium temperature <sup>(2)</sup>		A++	A++	A++	A++	A++	A++
SCOP medium temperature <sup>(2)</sup>	kWh/kWh	3,33	3,25	3,28	3,29	3,28	3,28
$\eta_{s,h}$ medium temperature <sup>(2)</sup>	%	130	127	128	129	128	128
Cooling capacity (EN14511) <sup>(3)</sup>	kW	76,9	88,1	126,5	142,7	158,7	184,3
Total input power (EN14511) <sup>(3)</sup>	kW	26,3	32,9	40,3	48,4	49,7	60,3
EER (EN14511) <sup>(3)</sup>	W/W	2,92	2,68	3,14	2,95	3,19	3,05
Sound power <sup>(4)</sup>	dB (A)	75	75	79	79	80	80
Sound pressure <sup>(5)</sup>	dB (A)	43	43	47	47	48	48
Power supply	V/Ph/Hz	400/3/50	400/3/50	400/3/50	400/3/50	400/3/50	400/3/50
Compressors / Circuits	n° / n°	2 / 1	2 / 1	4 / 2	4 / 2	4 / 2	4 / 2
Fans	n°	2	2	4	4	6	6
Refrigerant		R410A	R410A	R410A	R410A	R410A	R410A
Refrigerant charge	kg	27,0	27,0	50,0	50,0	55,0	55,0
Global warming potential (GWP)		2088	2088	2088	2088	2088	2088
Equivalent CO <sub>2</sub> charge	t	56,37	56,37	104,40	104,40	114,84	114,84
Water tank volume	l	300	300	500	500	500	500

Performances are referred to the following conditions:

(1) Heating: Ambient temperature 7°C DB, 6°C WB, water temperature 30/35°C.

(2) Average conditions, variable - Reg EU 811/2013

(3) Cooling: ambient air temperature 35°C, evaporator water temperature in/out 12/7 °C.

(4) Sound power level in accordance with ISO 3744..

(5) Sound pressure level at 10 mt from the unit in free field conditions in accordance with ISO 3744.

HE/NN/RV - P4U/P4S		252	312	452	502	602	752	852
Heating capacity (EN14511) <sup>(1)</sup>	kW	23,4	30,5	41,1	54,2	60,7	70,4	79,5
Total input power (EN14511) <sup>(1)</sup>	kW	5,0	6,4	8,8	11,7	12,4	14,7	17,41
COP (EN14511) <sup>(1)</sup>	W/W	4,69	4,75	4,69	4,64	4,89	4,78	4,56
Energy Class in low temperature <sup>(2)</sup>		A++	A++	A++	A++	A++	A++	A++
SCOP low temperature <sup>(2)</sup>	kWh/kWh	4,30	4,35	4,23	4,10	4,37	4,40	4,22
$\eta_{s,h}$ low temperature <sup>(2)</sup>	%	169	171	166	161	172	173	166
Energy Class in medium temperature <sup>(2)</sup>		A++	A++	A++	A++	A++	A++	A++
SCOP medium temperature <sup>(2)</sup>	kWh/kWh	3,34	3,48	3,42	3,34	3,47	3,45	3,38
$\eta_{s,h}$ medium temperature <sup>(2)</sup>	%	131	136	134	131	136	135	132
Cooling capacity (EN14511) <sup>(3)</sup>	kW	22,1	28,5	37,0	46,4	53,3	61,6	72,9
Total input power (EN14511) <sup>(3)</sup>	kW	6,9	9,1	12,6	14,9	16,8	20,9	25,1
EER (EN14511) <sup>(3)</sup>	W/W	3,20	3,15	2,93	3,11	3,18	2,95	2,90
Sound power <sup>(4)</sup>	dB (A)	68	69	71	71	71	72	72
Sound pressure <sup>(5)</sup>	dB (A)	36	37	39	39	39	40	40
Power supply	V/Ph/Hz	400/3+N/50	400/3/50	400/3/50	400/3/50	400/3/50	400/3/50	400/3/50
Compressors / Circuits	n° / n°	2 / 1	2 / 1	2 / 1	2 / 1	2 / 1	2 / 1	2 / 1
Fans	n°	2	2	2	2	2	2	2
Refrigerant		R410A	R410A	R410A	R410A	R410A	R410A	R410A
Refrigerant charge	kg	10,0	10,0	18,0	23,0	18,0	23,0	23,0
Global warming potential (GWP)		2088,0	2088	2088	2088	2088	2088	2088
Equivalent CO <sub>2</sub> charge	t	20,88	20,88	37,58	48,02	37,58	48,02	48,02

HE/NN/RV - P4U/P4S		1002	1202	1454	1654	1854	2154
Heating capacity (EN14511) <sup>(1)</sup>	kW	90,3	104,9	146,7	165,1	184,7	214,0
Total input power (EN14511) <sup>(1)</sup>	kW	18,6	22,1	31,5	36,6	40,0	48,0
COP (EN14511) <sup>(1)</sup>	W/W	4,87	4,75	4,66	4,51	4,62	4,46
Energy Class in low temperature <sup>(2)</sup>		A++	A++	A++	A++	A++	A++
SCOP low temperature <sup>(2)</sup>	kWh/kWh	4,42	4,31	4,31	4,15	4,23	4,12
$\eta_{s,h}$ low temperature <sup>(2)</sup>	%	174	169	169	163	166	162
Energy Class in medium temperature <sup>(2)</sup>		A++	A++	A++	A++	A++	A++
SCOP medium temperature <sup>(2)</sup>	kWh/kWh	3,52	3,50	3,41	3,40	3,47	3,42
$\eta_{s,h}$ medium temperature <sup>(2)</sup>	%	138	137	134	133	136	134
Cooling capacity (EN14511) <sup>(3)</sup>	kW	79,0	91,9	124,7	139,5	156,5	179,9
Total input power (EN14511) <sup>(3)</sup>	kW	24,7	29,8	41,5	50,9	50,8	63,3
EER (EN14511) <sup>(3)</sup>	W/W	3,20	3,08	3,01	2,74	3,08	2,84
Sound power <sup>(4)</sup>	dB (A)	72	72	74	74	75	75
Sound pressure <sup>(5)</sup>	dB (A)	40	40	42	42	43	43
Power supply	V/Ph/Hz	400/3/50	400/3/50	400/3/50	400/3/50	400/3/50	400/3/50
Compressors / Circuits	n° / n°	2 / 1	2 / 1	4/2	4/2	4/2	4/2
Fans	n°	3	3	4	4	6	6
Refrigerant		R410A	R410A	R410A	R410A	R410A	R410A
Refrigerant charge	kg	36,0	36,0	50,0	50,0	55,0	55,0
Global warming potential (GWP)		2088	2088	2088	2088	2088	2088
Equivalent CO <sub>2</sub> charge	t	75,16	75,16	104,40	104,40	114,84	114,84

Performances are referred to the following conditions:

(1) Heating: Ambient temperature 7°C DB, 6°C WB, water temperature 30/35°C.

(2) Average conditions, variable - Reg EU 811/2013

(3) Cooling: ambient air temperature 35°C, evaporator water temperature in/out 12/7 °C.

(4) Sound power level in accordance with ISO 3744..

(5) Sound pressure level at 10 mt from the unit in free field conditions in accordance with ISO 3744.

## COMPONENTS

### FRAME

All units are made from hot-galvanised sheet steel, painted with polyurethane powder enamel and stoved at 180°C to provide maximum protection against corrosion. The frame is self-supporting with removable panels. All screws and rivets used are made from stainless steel.

The standard colour of the units is RAL9018.

### REFRIGERANT CIRCUIT

The refrigerant utilised is R410A. The refrigerant circuit is assembled using internationally recognised brand name components with all brazing and welding being performed in accordance with ISO 97/23. The refrigerant circuit includes: sight glass, filter drier, two thermal expansion valves (one for cooling mode, one for heating mode) with external equalizer, 4 way reversing valve, check valves, liquid receiver, Schrader valves for maintenance and control, pressure safety device (for compliance with PED regulations). The circuit also includes an AISI316 stainless steel heat exchanger that is used as an economizer plus an additional expansion valve for refrigerant vapour injection.

### COMPRESSORS

Units use scroll compressors that are equipped with E.V.I. technology, a versatile method of improving system capacity and efficiency. EVI stands for "Enhanced Vapour Injection." The technology involves injecting refrigerant vapour into the middle of the compression process, a procedure that significantly boosts capacity and efficiency. Each scroll compressor used in these units is similar to a two-stage compressor with built-in inter-stage cooling. The process begins when a portion of the condenser liquid is extracted and expanded through an expansion valve. The low temperature liquid/gas mixture produced is injected into a heat exchanger that operates as a sub cooler. Any liquid is evaporated and the vapour produced is superheated.

The superheated vapour is then injected into an intermediate port in the scroll compressor. This cold vapour reduces the temperature of the compressed gas thus enabling the compressor to raise the pressure to levels (and temperatures) beyond that possible with a single stage scroll. The additional sub cooling of the main volume of liquid refrigerant increases the evaporator capacity. This compressor technology generates a larger pressure ratio between condensing and evaporating pressures, with significant performance improvement. In all units the compressors are connected in tandem. The compressors are all supplied with a crankcase heater and thermal overload protection by a klixon embedded in the motor winding. They are mounted in a separate enclosure in order to be separated from the air stream thus enabling them to be maintained even if the unit is operating. Access to this enclosure is by the front panel of the unit. The crankcase heater is always powered when the compressor is in stand-by.

### SOURCE HEAT EXCHANGER

The source heat exchanger is made from copper pipes and aluminium fins. Dimensioning of the copper pipes and the aluminium wings is optimized in order to obtain excellent performance. The tubes are mechanically expanded into the fins in order to maximise heat transfer. Furthermore, the design guarantees a low air side pressure drop thus enabling the use of low rotation speed (and hence low noise) fans. All heat exchangers are supplied standard with fins hydrophilic coating.

### USER HEAT EXCHANGERS

The user heat exchanger is a braze welded, plate type heat exchanger, manufactured from AISI 316 stainless steel. The use of this type of exchanger results in a massive reduction of the refrigerant charge of the unit compared to a traditional shell-in-tube type. A further advantage is a reduction in the overall dimensions of the unit.

The exchangers are factory insulated with flexible close cell

material and can be fitted with an antifreeze heater (accessory). Each exchanger is fitted with a temperature sensor on the discharge water side for antifreeze protection.

### FANS

The fans are direct drive axial type with aluminium aerofoil blades, are statically and dynamically balanced and are supplied complete with a safety fan guard complying with the requirements of EN 60335. They are fixed to the unit frame via rubber antivibration mountings. In the LS versions the fans are 6 poles type (approx 900 rpm), in the XL versions the fans are 8 poles type (approx 600 rpm), in the NN versions the fans are 12 poles type (approx 450 rpm). The motors are fitted with integrated thermal overload protection and have a moisture protection rating of IP 54.

### MICROPROCESSORS

All units are supplied as standard complete with control panel. The microprocessor controls the following functions: control of the water temperature, antifreeze protection, compressor timing, compressor automatic starting sequence (For multiple compressors), alarm reset.

The control panel is supplied with display showing all operational icons. The microprocessor is set for automatic defrost (when operating in severe ambient conditions) and for summer/ winter change over (only for RV versions).

The control also manages the anti-legionella program, the integration with other heating sources (electric heaters, boilers, solar panels etc), the operation of a three port modulating valve (for diverting to DHW or heating) and both the heating circuit pump and the domestic hot water circuit pump. If required (available as an option), the microprocessor can be configured in order for it to connect to a site BMS system thus enabling remote control and management.

### ELECTRIC ENCLOSURE

The enclosure is manufactured in order to comply with the requirements of the electromagnetic compatibility standards CEE EN60204. Access to electrical cabinet in quick and easy thanks to hinged panels. The following components are supplied as standard on all units: main switch, a sequence relay that disables the power supply in the event that the phase sequence is incorrect (scroll compressors can be damaged if they rotate in the wrong direction), thermal overloads (protection of pumps and fans), compressor fuses, control circuit automatic breakers, compressor contactors, fan contactors and pump contactors. The terminal board has volt free contacts for remote ON-OFF, Summer/ winter change over (heat pumps only) and general alarm.

### CONTROL AND PROTECTION DEVICES

All units are supplied with the following controls and protections: user water return temperature sensor, antifreeze protection temperature sensor installed on users water output, domestic hot water supply and return temperature sensors (only versions P2S), high pressure manual reset, low pressure automatic reset, compressor thermal protection, air fan, thermal protection, pressure transducer (used to optimize the defrost cycle and to adjust the fan speed depending on ambient conditions), flow switch. All units are also fitted with a temperature probe sensor with "Energy Saving" function, supplied in a separate plastic box, which can be used to stop the pump use during periods of stand-by, when the water temperature reaches the set point. Doing this the power consumption of the unit is strongly reduced. The probe sensor must be positioned in the hydraulic compensator present at the screening technique. The domestic hot water circuit (only versions P2S) is already equipped with this probe, but it must be installed in the user circuit.

## OPERATION LIMITS

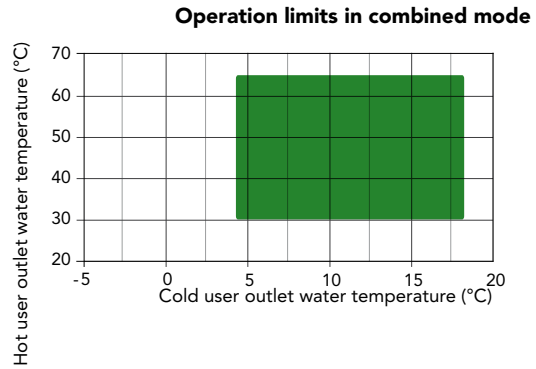
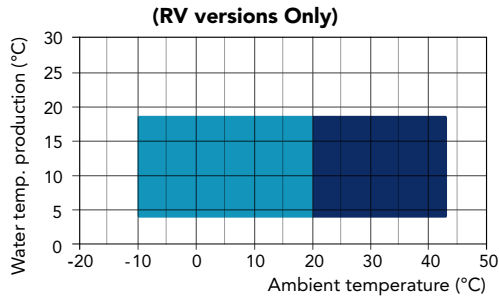
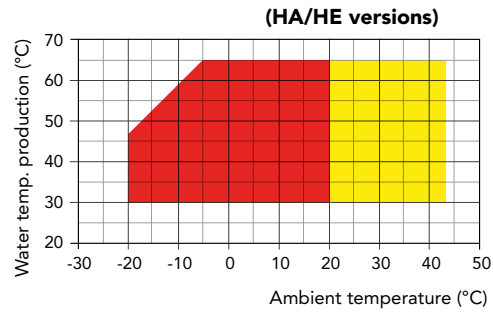
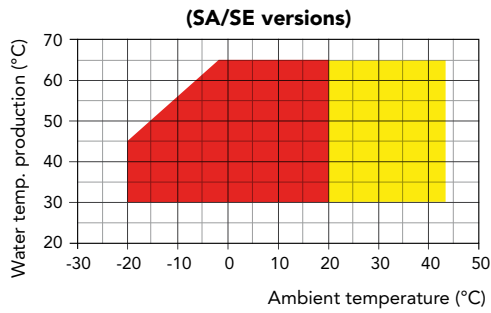

- Heating mode
- Heating mode with head pressure control (DCCF)
- Cooling with head pressure control (DCCF)

- Cooling mode
- Combined mode

## VERSIONS

### P4U version

The P4U units use 4 hydraulic connections and are used in modern 4-pipe systems. In these systems, cold and hot water is always available (in every period of the year) and present in the specific hydraulic circuit.

These systems allow the simultaneous production of cold water and hot water using 4 hydraulic connections, 2 connections are related to the hot water circuit, 2 connections are related to the cold water circuit.

The plant thus conceived is able to heat and, at the same time, if required, to cool with very high energy efficiencies. In this configuration, however, the units are also able to produce hot or cold water separately at any time of the year.

The units are supplied with 2 heat exchangers, one dedicated to the production of cold water and one dedicated to the production of hot water.

The operating modes are:

**1. User water heating:** The unit behaves like a normal air/water heat pump in heating mode, using the finned heat exchanger as the source and the A plate heat exchanger as user.

**2. User water cooling:** The unit behaves like a normal air / water chiller in cooling mode, using the finned exchanger as the source and the B plate heat exchanger as user.

**3. Simultaneous user Cooling + heating:** The unit behaves like a water / water heat pump, using the plate heat exchanger B as the cold user and the plate heat exchanger A as hot user. This version is not able to produce domestic hot water.

### P4S Version

The P4S units have been designed to meet the needs of 2 + 2 pipe systems (2 user side pipes, 2 domestic hot water pipes) throughout the year. The units are supplied with 2 exchangers, one dedicated to the production of the user cold and hot water and one dedicated to the production of domestic hot water only (D.H.W.). The production of domestic hot water always has priority. In winter mode the activation of D.H.W. production temporarily stops the production of the user hot water, which is re-

## P4U VERSION

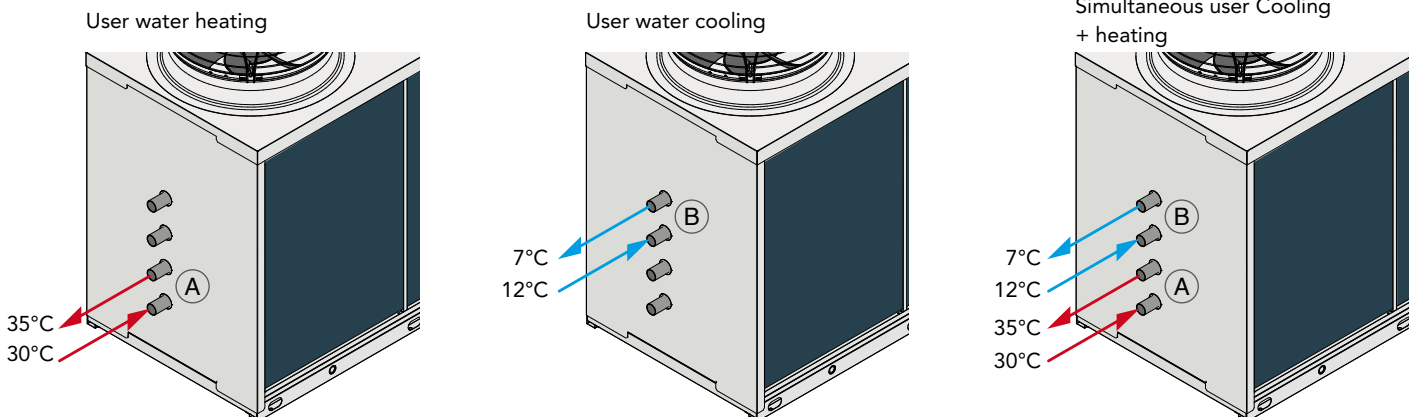

The above scheme is for illustrative purposes only. For the correct pipes placement, please refer to the units technical manual.

stored when the D.H.W. accumulation reaches the temperature set. In summer mode the unit will switch to cooling (by activating the reverse cycle valve installed in the refrigerant circuit) and any request for domestic hot water will allow, at the same time, the production of cold water. In this operating mode, the system can simultaneously produce cold water and domestic hot water. Domestic hot water, in summer mode, is produced by heat recovery and therefore free of charge. When the temperature measured by the D.H.W. sensor reaches the set, the D.H.W. water pump is stopped and normal operation is restored in cooling mode.

The operating modes are:

**1. User water heating:** The unit behaves like a normal air/water heat pump in heating mode, using the finned heat exchanger as the source and the A plate heat exchanger as user.

**2. User water cooling:** The unit behaves like a normal air/water chiller in cooling mode, using the finned heat exchanger as the source and the A plate heat exchanger as user.

**3. Domestic hot water production (D.H.W.):** The unit behaves like a normal air / water heat pump in heating mode, using the finned heat exchanger as the source and as a user the plate heat exchanger B (a special D.H.W. heat exchanger that works with a higher set point).

**4. User water cooling + D.H.W. production:** The unit behaves like a water / water heat pump, using the plate heat exchanger A as the cold user and the plate heat exchanger B as D.H.W. production).

**SA Version**

Standard efficiency version, according to current standard. Unit equipped with AC fans.

**SE Version**

Standard efficiency version, according to current standard. Unit equipped with EC fans.

**HA Version**

High efficiency version, according to current standard. Unit equipped with AC fans.

**HE Version**

High efficiency version, according to current standard. Unit equipped with EC fans.

**Version LS**

This version includes the complete acoustic insulation of the unit with compressor jackets and insulating material made with high density media and the interposition of heavy bitumen layer.

**Super low noise and ultra low noise versions XL and NN**

All units in XL and NN versions are supplied, as standard, with the latest 'Floating Frame' technology that completely isolates the compressors from the main casing, thereby eliminating vibration and noise from this source. The 'Floating Frame' is a special vibration and acoustic damping system that consists of a base plate and acoustic enclosure that houses the compressors. The base plate is separated from the supporting frame of the unit by soft steel springs that have a high damping power. Within the enclosure, the compressors are mounted on rubber shock absorbers on the floating base plate. The enclosure is manufactured from galvanized steel sandwich panels that have a micro-perforated inner skin and a core of 30 mm thick, high density (25 kg/m<sup>3</sup>). The entire arrangement provides a double damping system and acoustic attenuation. The compressor refrigerant pipes are connected to the refrigerant circuit through "anaconda" flexible connections. Flexible connections are also used on the water pipework within the unit. The combination of these systems results in an overall noise reduction in the region of 6-8 dB(A).

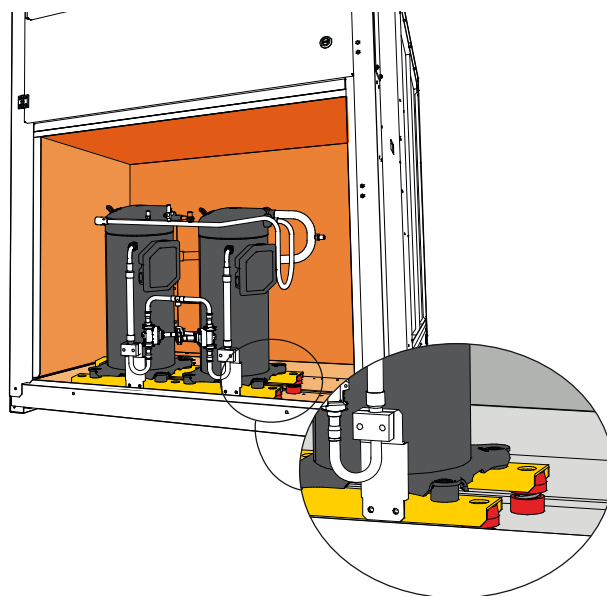

**P4S VERSION**

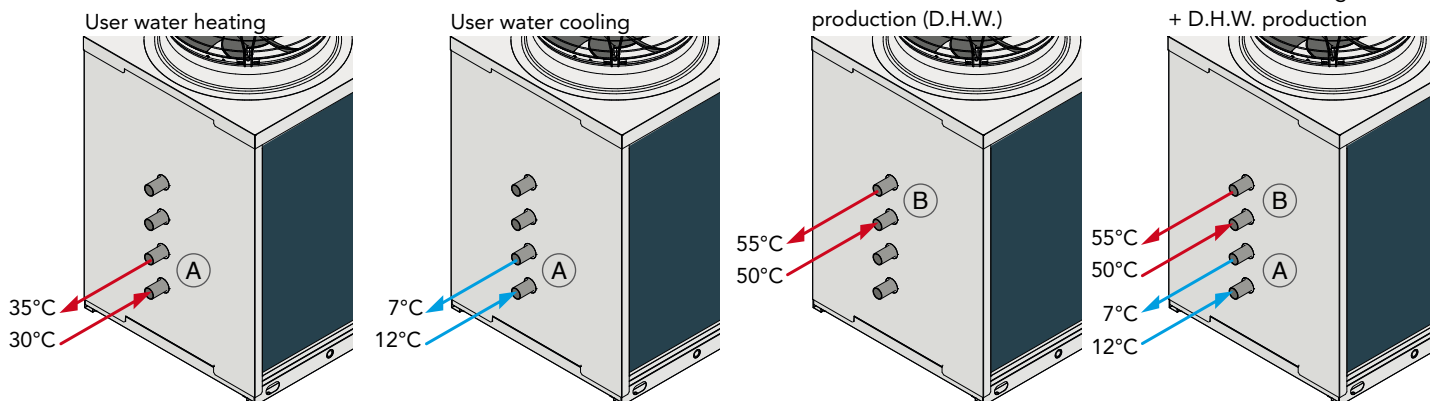

The above scheme is for illustrative purposes only. For the correct pipes placement, please refer to the units technical manual.

# ACCESSORIES

LZT/P4

LZT		242 252	292 302	312	432	452	492	502	592	602
Flow switch		●	●	●	●	●	●	●	●	●
“Floating frame” Technology - LS Version		-	-	-	-	-	-	-	-	-
“Floating frame” Technology - XL - NN Version		●	●	●	●	●	●	●	●	●
E.C. fans - SA/LS versions	<b>VECE</b>	-	-	-	-	-	-	-	-	-
E.C. fans - SE/LS versions	<b>VECE</b>	●	●	●	●	●	●	●	●	●
E.C. fans - HA/LS - HA/XL versions	<b>VECE</b>	-	-	-	-	-	-	-	-	-
E.C. fans - HE/LS - HE/XL - HE/NN versions	<b>VECE</b>	●	●	●	●	●	●	●	●	●
Condensate discharge drip tray with antifreeze heater	<b>BRCA</b>	○	○	○	○	○	○	○	○	○
Condensing pressure control by transducer & EC Fans (only for SE and HE)		●	●	●	●	●	●	●	●	●
Fans regulation by phase cut (only SA - HA)	<b>DCCF</b>	●	●	●	●	●	●	●	●	●
Antifreeze kit for 4 pipe units	<b>RAEV4</b>	○	○	○	○	○	○	○	○	○
Electronic soft starter	<b>DSSE</b>	○	○	○	○	○	○	○	○	○
Serial interface card RS485	<b>INSE</b>	●	●	●	●	●	●	●	●	●
Rubber anti-vibration mountings	<b>KAVG</b>	○	○	○	○	○	○	○	○	○
Remote control panel	<b>PCRL</b>	○	○	○	○	○	○	○	○	○
Electronic expansion valve	<b>VTEE</b>	○	○	○	○	○	○	○	○	○
Cascade control system via RS485	<b>SGRS</b>	○	○	○	○	○	○	○	○	○
Hydraulic kit with one pump with tank *	<b>A1ZZU</b>	○	○	○	○	○	○	○	○	○
Hydraulic kit with two pumps with tank *	<b>A2ZZU</b>	○	○	○	○	○	○	○	○	○
Hydraulic kit with one pump without tank *	<b>A1NTU</b>	○	○	○	○	○	○	○	○	○
Hydraulic kit with two pumps without tank *	<b>A2NTU</b>	○	○	○	○	○	○	○	○	○

\* Not available for NN versions

● Standard ○ Optional - Not available

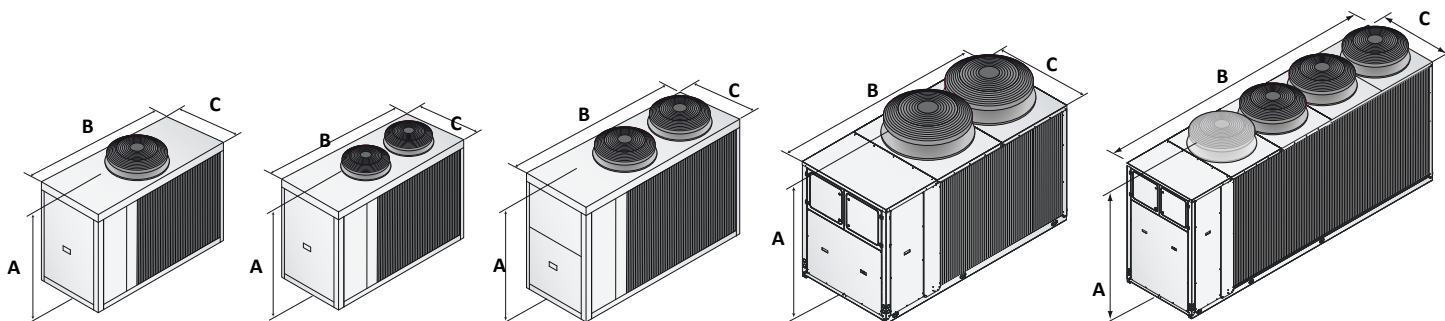

**SA/SE 242-292**  
**HA/HE/LS 242-292**

**HA-HE/XL 252 - 302**  
**HE/NN 252 - 312**

**SA/SE 432 - 492 - 592**  
**HA-HE/LS-XL 432 - 492**  
**HE/NN 312**

**SA/SE 752-852**  
**HA-HE/LS-XL 592 - 602 - 752 - 852**  
**HE/NN 452 - 502 - 602 - 752 - 852**

**SA/SE 1002-1202**  
**HE/NN 1002-1202**

		242/252	292/302	312	432	452	492	502	592	602
A (mm)	<b>SA-SE/LS</b>	1500	1500	--	1690	--	1690	--	1690	--
B (mm)	<b>SA-SE/LS</b>	1915	1915	--	2400	--	2400	--	2400	--
C (mm)	<b>SA-SE/LS</b>	875	875	--	1150	--	1150	--	1150	--
kg	<b>SA-SE/LS</b>	1000	1000	--	1500	--	1500	--	1500	--
A (mm)	<b>HA-HE/LS</b>	1500	1500	--	1670	--	1690	--	--	1820
B (mm)	<b>HA-HE/LS</b>	1915	1915	--	2400	--	2400	--	--	2905
C (mm)	<b>HA-HE/LS</b>	875	875	--	1150	--	1150	--	--	1150
kg	<b>HA-HE/LS</b>	1000	1000	--	1500	--	1500	--	--	1060
A (mm)	<b>HA-HE/XL</b>	1500	1500	--	1670	--	1690	--	--	1820
B (mm)	<b>HA-HE/XL</b>	1915	1915	--	2400	--	2400	--	--	2905
C (mm)	<b>HA-HE/XL</b>	875	875	--	1150	--	1150	--	--	1150
kg	<b>HA-HE/XL</b>	1000	1000	--	1500	--	1500	--	--	1080
A (mm)	<b>HE/NN</b>	1500	--	1690	--	1820	--	1880	--	1880
B (mm)	<b>HE/NN</b>	1915	--	2400	--	2905	--	2905	--	2905
C (mm)	<b>HE/NN</b>	875	--	1150	--	1150	--	1150	--	1150
kg	<b>HE/NN</b>	1000	--	1500	--	1080	--	1100	--	1110

LZT		752	852	1002	1202	1454	1654	1854	2154
Flow switch		●	●	●	●	●	●	●	●
"Floating frame" Technology - LS Version		-	-	-	-	-	-	-	-
"Floating frame" Technology - XL - NN Version		●	●	●	●	●	●	●	●
E.C. fans - SA/LS versions	<b>VECE</b>	-	-	-	-	-	-	-	-
E.C. fans - SE/LS versions	<b>VECE</b>	●	●	●	●	●	●	●	●
E.C. fans - HA/LS - HA/XL versions	<b>VECE</b>	-	-	-	-	-	-	-	-
E.C. fans - HE/LS - HE/XL - HE/NN versions	<b>VECE</b>	●	●	●	●	●	●	●	●
Condensate discharge drip tray with antifreeze heater	<b>BRCA</b>	○	○	○	○	○	○	○	○
Condensing pressure control by transducer & EC Fans (only for SE and HE)		●	●	●	●	●	●	●	●
Fans regulation by phase cut (only SA - HA)	<b>DCCF</b>	●	●	●	●	●	●	●	●
Antifreeze kit for 4 pipe units	<b>RAEV4</b>	○	○	○	○	○	○	○	○
Electronic soft starter	<b>DSSE</b>	○	○	○	○	○	○	○	○
Serial interface card RS485	<b>INSE</b>	●	●	●	●	●	●	●	●
Rubber anti-vibration mountings	<b>KAVG</b>	○	○	○	○	○	○	○	○
Remote control panel	<b>PCRL</b>	○	○	○	○	○	○	○	○
Electronic expansion valve	<b>VTEE</b>	○	○	○	○	○	○	○	○
Cascade control system via RS485	<b>SGRS</b>	○	○	○	○	○	○	○	○
Hydraulic kit with one pump with tank *	<b>A1ZZU</b>	○	○	○	○	○	○	○	○
Hydraulic kit with two pumps with tank *	<b>A2ZZU</b>	○	○	○	○	○	○	○	○
Hydraulic kit with one pump without tank *	<b>A1NTU</b>	○	○	○	○	○	○	○	○
Hydraulic kit with two pumps without tank *	<b>A2NTU</b>	○	○	○	○	○	○	○	○

\* Not available for NN versions

● Standard ○ Optional - Not available

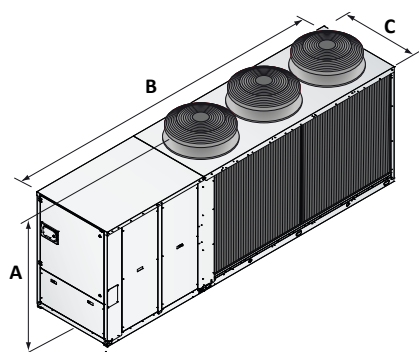

**HA-HE/LS** 1454 - 1654  
1854 - 2154

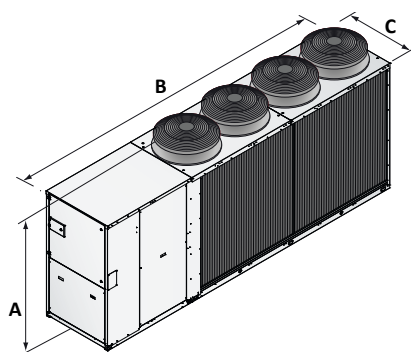

**SA-SE/LS** 1454 - 1654  
1854 - 2154

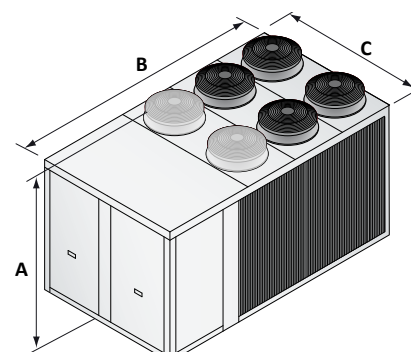

**HA-HE/XL** 1454 - 1654 - 1854 - 2154  
**HE/NN** 1454 - 1654 - 1854 - 2154

		752	852	1002	1202	1454	1654	1854	2154
A (mm)	<b>SA-SE/LS</b>	1880	1880	1890	1890	2310	2310	2310	2310
B (mm)	<b>SA-SE/LS</b>	2905	2905	3905	3905	5300	5300	5300	5300
C (mm)	<b>SA-SE/LS</b>	1150	1150	1150	1150	1150	1150	1150	1150
kg	<b>SA-SE/LS</b>	2000	2000	2000	2000	2500	2540	2580	2620
A (mm)	<b>HA-HE/LS</b>	1880	1880	1880	1880	1895	1895	1895	1895
B (mm)	<b>HA-HE/LS</b>	2905	2905	2905	2905	4695	4695	4695	4695
C (mm)	<b>HA-HE/LS</b>	1150	1150	1150	1150	1150	1150	1150	1150
kg	<b>HA-HE/LS</b>	2000	2000	2000	2000	2580	2640	2720	2760
A (mm)	<b>HA-HE/XL</b>	1880	1880	1880	1880	2350	2350	2350	2350
B (mm)	<b>HA-HE/XL</b>	2905	2905	2905	2905	4205	4205	4205	4205
C (mm)	<b>HA-HE/XL</b>	1150	1150	1150	1150	2210	2210	2210	2210
kg	<b>HA-HE/XL</b>	2000	2000	2000	2000	2500	2540	2580	2620
A (mm)	<b>HE/NN</b>	1880	1880	1890	1890	2350	2350	2350	2350
B (mm)	<b>HE/NN</b>	2905	2905	3905	3905	4205	4205	4205	4205
C (mm)	<b>HE/NN</b>	1150	1150	1150	1150	2210	2210	2210	2210
kg	<b>HE/NN</b>	2000	2000	2000	2000	2750	2800	2840	2890





**Heat pumps & multipurpose units - Products Catalogue** | Rev.1 Version September 2024 | ENG

Copyright © Enex Technologies

All rights reserved in all Countries.

The technical data and information expressed in this publication are owned by Enex Technologies and have general information. With a view to continuous improvement, Enex Technologies has the right to make at any time, without any obligation or commitment, all the modifications deemed necessary for the improvement of the product, for this reason even substantial changes can be made to the documentation without notice. The example images of the products and components inside the units are illustrative and therefore any brands of the components functional to the construction of the units may differ from any brands represented in this document. This catalog has been prepared with the utmost care and attention to the contents displayed, nevertheless Enex Technologies cannot assume any responsibility deriving from the use, direct or indirect, of the information contained therein.

